



VARI***LITE**

IP IMAGE PROJECTING PROFILE

FULL COLOR (FC)

USER MANUAL

INTRODUCTION

OUR GOAL

We are committed to providing you the highest quality in customer service. Our comprehensive resources are available to help your business succeed and ensure you get the full benefit of being a Vari-Lite customer.

TECHNICAL SUPPORT

Our Service and Support team is tasked with online and field support, repair, demo, commissioning, maintenance contracts, and technical training for fixtures and systems. In addition, this team plays a large role in a Systems sales, responsible for administering final commissioning, record-keeping, and organizing services. Refer to the back cover of this User Manual for contacts in your region or visit www.vari-lite.com/support

CUSTOMER SERVICE

Customer Service is responsible for boxed goods and spare parts quotations, order entry and fulfilment, project delivery, lead times, and general account management. They also manage all after sales warranty fulfilment, RGA, and repairs invoicing in tandem with our After Sales Service & Support team. Visit our website to find a customer service agent in your region.

ADDITIONAL DOCUMENTATION

Additional product documentation, including DMX maps, software, and photometric reports, are available for download on our website.

For more information on installing DMX512 control systems, the following publication is available for purchase from the United States Institute for Theatre Technology (USITT), "Recommended Practice for DMX512: A Guide for Users and Installers, 2nd edition" (ISBN: 9780955703522).

USITT Contact Information:

USITT

315 South Crouse Avenue, Suite 200

Syracuse, New York 13210-1844 USA

Phone: 800-938-7488 or +1-315-463-6463

Fax: 866-398-7488 or +1-315-463-6525

Website: www.usitt.org

ABOUT THIS DOCUMENT

Read all instructions before installing or using this product. Retain this User Manual for future reference.

Additional product information and descriptions may be found on the product data sheet(s) which can be downloaded from the website at www.vari-lite.com.

This User Manual provides necessary information regarding safety, installation, operation and routine maintenance for IP Image Projecting Profile, FC. Familiarizing yourself with this information will help you to get the most out of your product.

WARNING: It is important to read ALL accompanying safety and installation instructions to avoid damage to the product and potential injury to yourself or others.

SAFETY WARNINGS AND NOTICES

Read this user manual in full before attempting to install, operate or maintain the fixture to which it relates. This user manual is intended to provide general guidance to such suitably qualified personnel. Installation and operation of the fixture are to be performed by qualified personnel only.

When using electrical equipment, basic safety precautions should always be followed including the following:

READ AND FOLLOW ALL SAFETY INSTRUCTIONS.

- For indoor, dry location use only. Do not use outdoors unless fixture is suitably IP rated.
- Use safety tether when mounting.
- Equipment should be mounted in locations and at heights where it will not be readily subjected to tampering by unauthorized personnel.
- Not for residential use. Do not use this equipment for other than intended use.
- Note distance requirement(s) from combustible materials or illuminated objects. Do not mount near gas or electric heaters.
- Install only in locations with adequate ventilation. Ensure sure that ventilation slots are not blocked.
- Ensure that the voltage and frequency of the power supply match the power requirements of the fixture.
- The fixture must be earthed/grounded to the appropriate conductor.
- Do not operate fixture outside the specified ambient temperature range.
- Do not connect the fixture to any dimmer pack.
- The use of accessory equipment not recommended by the manufacturer may cause an unsafe condition and void warranty.
- Refer service to qualified personnel. This fixture contains no user serviceable parts.
- Prior to first use, carefully inspect fixture to ensure no damage has occurred during shipping.
- Materials used in the manufacturing process can cause strong odors when the product is new. These odors dissipate over time.
- Prior to each use, carefully inspect power cables and replace any damaged cables.
- Exterior surfaces of the luminaire will be hot during operation. Take appropriate precautions.
- Continuous use of the fixture may shorten the lifespan. Power down the fixture when not in use.
- Do not cycle power on and off repeatedly. Disconnect mains power if the fixture is not used for an extended period.
- Clean fixtures regularly, particularly when working in a dusty environment.
- Never touch power cables or wires while the fixture is powered on.
- Avoid entangling power wires with other cables.
- In the event of a serious operating problem, immediately discontinue using the fixture.
- It is hazardous to operate luminaires without lens or shield. Shields, lenses, or ultraviolet screens shall be changed if they have become visibly damaged to such an extent that their effectiveness is impaired, for example, by cracks or deep scratches.
- Original packing materials can be reused for transporting the fixture.
- Do not look directly at the LED light beam while the fixture is on.
- This is a Class A product. In a domestic environment this product may cause radio interference, in which case, the user may be required to take adequate measures.
- The light source contained in this luminaire shall only be replaced by the manufacturer or service agent or similarly qualified person.

SAVE THESE INSTRUCTIONS.

WARNING: Refer to National Electrical Code® and local codes for cable specifications. Failure to use proper cable can result in damage to equipment or danger to personnel. Caution Against Direct Sunlight Through Front Lens Assembly

CAUTION AGAINST DIRECT SUNLIGHT THROUGH FRONT LENS ASSEMBLY

The design and nature of the front lens assembly in Vari-Lite LLC luminaires is to efficiently focus the light energy from the luminaire's lamp for maximum light output.

- When the front lens assembly is exposed to direct sunlight or intense light from neighboring fixtures, the lens will collect and intensify this light and focus it back into the fixture. Intense sunlight or beams from other fixtures can cause damage to internal assemblies contained within the fixture.
- When fixture is not in use and direct sunlight or other intense light is present, position luminaires so their front lens assembly is not directly exposed to the light source.

CAUTION AGAINST POWERING LUMINAIRES FROM DIMMER CIRCUITS

It is not recommended to power any Vari-Lite LLC luminaire from a dimmer - even in 'NONDIM' mode. Dimmer and non-dim modules are not suitable sources of power because their output modifies the AC wave form. This may work for a short time, but eventually results in power problems, luminaire mis-operation and/or failure.

- When using a power distribution rack, do not use dimmer or non-dim modules to power any Vari-Lite LLC luminaire. Damage to the luminaire can occur.
- Using a dimmer or non-dim module to power your Vari-Lite LLC luminaire will void your luminaire's warranty.

CAUTION AGAINST THE USE OF THIRD PARTY PARTS OR ACCESSORIES

- Heat and heat distribution are important factors when operating Vari-Lite LLC luminaires. Vari-Lite LLC luminaires are designed to dissipate heat efficiently and safely. Any blockages or obstructions, such as aftermarket baffles, covers, enclosures, etc. can interrupt the luminaire's ability to dissipate heat properly and can damage the luminaire.
- Vari-Lite LLC cannot be responsible for issues arising from non-approved parts and accessories installed on or used with any Vari-Lite LLC product. Customers of such products should contact the manufacturer directly for assistance and support.

TRANSPORTING LUMINAIRES

When shipping or transporting luminaires, Vari-Lite LLC recommends that the luminaire(s) be sufficiently protected against any (including, but not limited to) shock, vibration, drops, jarring, exposure to the environment, etc.

Failure to sufficiently protect any Vari-Lite LLC luminaire during shipping or transportation will result in damage and void the luminaire's warranty. Vari-Lite LLC will not be responsible for any shipping damage or breakage of any product under any circumstances. Vari-Lite LLC will not be responsible for any third party case manufacturer's cases.

NOTE: As with all automated luminaires, proper handling and suitable protective shipping cases should be used when transporting fixtures to reduce the risk of damage.

TRANSPORTATION AND SHIPPING CASE REQUIREMENTS

Cases to transport Vari-Lite LLC luminaires should meet the following loading requirements:

- Luminaire head, yoke, and enclosure sub-assemblies shall be equally supported and constrained where no one sub-assembly (head, yoke, or enclosure) fully supports the entire mass of the luminaire.
- The interior of the case shall be of high quality and uniform density foam. The foam shall be of the same type and density throughout as to equally and uniformly support loading at every contact surface.
- The case shall, when laid on any of its six (6) surfaces, maintain the loading requirements outlined above.
- All cases not meeting the aforementioned loading requirements, with wheels, shall have markings on the exterior of the case that the unit is to be transported on its wheels only (e.g. "Case must be transported and remain [at all times] on its wheels").

COMPLIANCE NOTICE



FCC DECLARATION OF CONFORMITY

This equipment has been tested and found to comply with the limits for a Class A digital device pursuant to Part 15 of FCC Rules. These limits are designed to provide reasonable protection against harmful interference when this equipment is operated in a commercial environment. This equipment generates, uses, and can radiate radio frequency energy and, if not installed and used in accordance with Vari-Lite system, service, and safety guidelines, may cause harmful interference to radio communications.

As tested under this standard:

FCC 47CFR 15B cIA*CEI

Issued:2009/10/01 Title 47 CFR Part 15 Subpart B Unintentional Radiators Class A

Operation of this equipment in a residential area is likely to cause harmful interference, in which case the user will be required to correct the interference at his/her own expense.



EU DECLARATION OF CONFORMITY

We, Vari-Lite LLC., 10911 Petal Street, Dallas, Texas 75238, declare under our responsibility for the products contained herein are in conformity with the essential requirements of the following European Directives and harmonized standards:

Low Voltage Director (LVD), 2006/95/EC

EN 60589-2-17:1984+A1:1987+A2:1990 used in conjunction with 60598-1:2008/A11:2009

Electromagnetic Compatibility Directive (EMC), 2004//108/EC

EN 55022:2010, EN55024:2010

HOW TO OBTAIN WARRANTY SERVICE

A copy of the Limited Warranty card was included in the shipping package for this product.

To obtain warranty service, please contact customer service at 1-214-647-7880, or **entertainment.service@signify.com** and request a Return Material Authorization (RMA) for warranty service. You will need to provide the model and serial number of the item being returned, a description of the problem or failure and the name of the registered user or organization. If available, you should have your sales invoice to establish the date of sale as the beginning of the warranty period. Once you obtain the RMA, pack the unit in a secure shipping container or in its original packing box. Be sure to clearly indicate the RMA number on all packing lists, correspondence, and shipping labels. If available, please include a copy of your invoice (as proof of purchase) in the shipping container.

With the RMA number written legibly on or near the shipping address label, return the unit, freight prepaid, to:

Vari-Lite LLC
Attention: Warranty Service (RMA# _____)
10911 Petal Street
Dallas, Texas 75238
USA

As stated in the warranty, it is required that the shipment be insured and FOB our service center.

IMPORTANT! When returning products to Vari-Lite for repairs (warranty or out-of-warranty) from a country other than the USA, "Vari-Lite LLC", must appear in the address block as the Importer of Record (IOR) on all shipping documentation, Commercial Invoices, etc. This must be done in order to clear customs in a timely manner and prevent returns.

1 DESCRIPTION

FEATURES

- High output IP65 rated LED Profile - modern theatrical profile built for the outdoors.
- High CRI RGBALC Color System with SmartColor Control - wide range of vivid color options that can be programmed using CYM.
- Independent color mixing and temperature controls - match color pallet to color temperature without manual adjustment for simpler programming.
- Wide range zoom (18° to 30°) and adjustable focus can be controlled manually and/or by DMX - adjust the fixture where and how you need.
- Wire free DMX - integrated Wireless solution WDMX receiver.

For detailed product information, please refer to the Product Guide at <https://www.vari-lite.com/global/products/ip-image-projecting-profile-fc>

COMPONENTS

The document provides installation and operation instructions for the following products:

- IP Image Projecting Profile, Full Color

Read all instructions before installing or using this product. Retain this manual for future reference. Additional product information and descriptions may be found on the product specification sheet.

INCLUDED ITEMS

Each IP Image Projecting Profile, Full Color luminaire includes the following items:

- IP Image Projecting Profile, Full Color
- Quick Start Guide

INCLUDED ITEMS



2 INSTALLATION

MOUNTING

The unit should be mounted via its screw holes on the bracket. Always ensure that the unit is firmly fixed to avoid vibration and slipping while operating. When installing the fixture, always use a safety cable that is certified to hold up to 12 times the fixture's own weight.

The luminaire must be installed by qualified professionals.

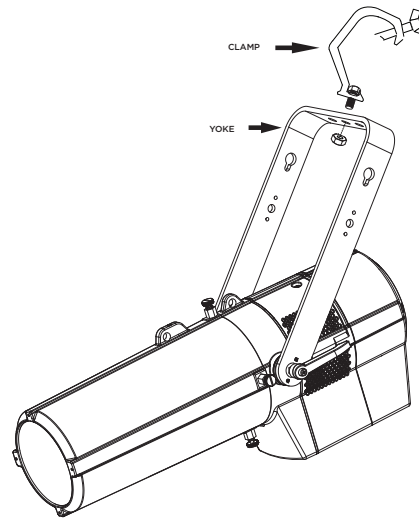

REMOVE AND INSTALL FRONT COVER

The front cover can be removed to set the manual shutters, install the optional rotating gobo assembly or clean the lens

Step 1. Remove power from luminaire

Step 2. Loosen the 4 captive screws. Use a flatblade screwdriver if required

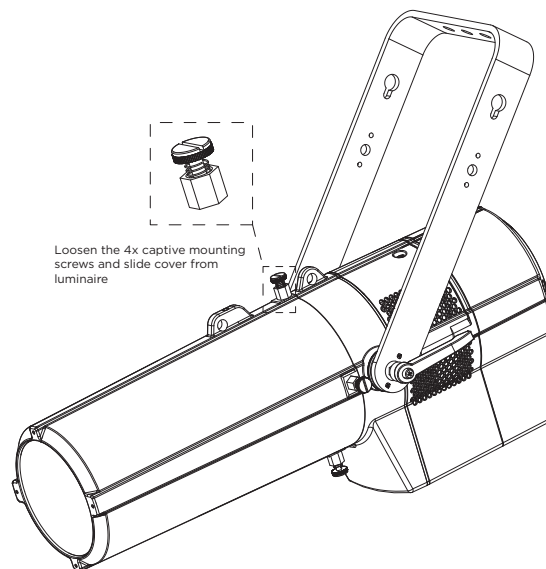

Step 3. Slide the cover off the fixture.

NOTE: There is no teather connecting the cover to the body!

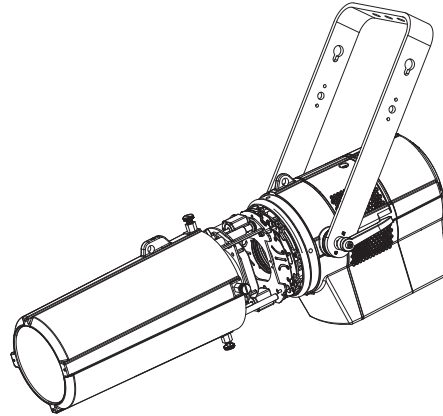

- Step 4. Before replacing cover, inspect the double o-rings on the body. Ensure they are in place with no damage. If damaged, replace before replacing cover
- Step 5. Slide the cover into place. Ensure all 4 mounting screws are aligned to their holes. Also ensure the external safety mount is facing up in relation to the fixture.
- Step 6. Tighten all four mounting screws

SET FRAMING SHUTTERS

- Step 1. Remove the front cover as described above.
- Step 2. Slide the locking lever, for the shutter you wish to move, to the Off position.
- Step 3. Using the serrated edge wheel, move the shutter to desired angle.
- Step 4. Slide the locking lever to the On position.
- Step 5. Repeat for all shutters as desired.

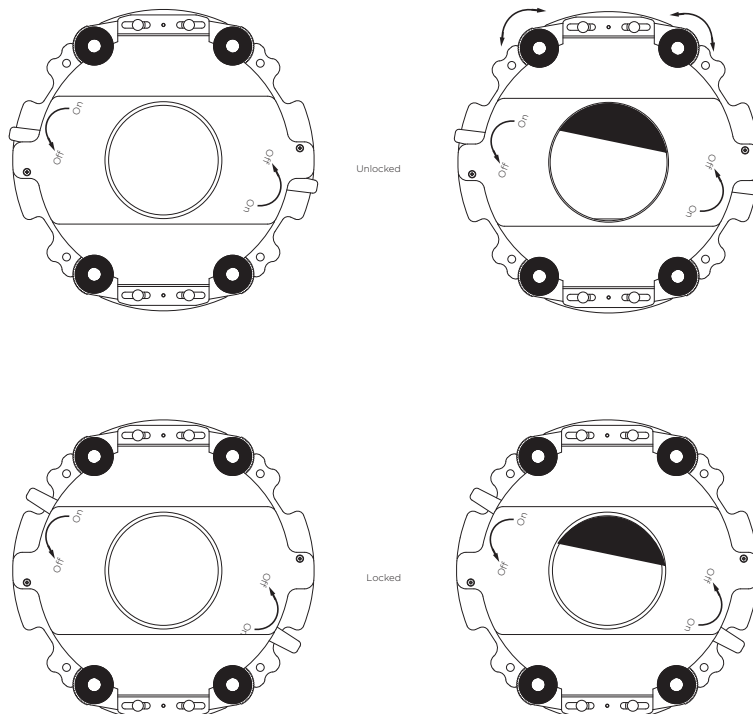

INSTALL OPTIONAL GOBO ROTATOR - 64505-003

- Step 1. Remove gobo rotator from package and remove retaining spring and gobo spacer.
- Step 2. Install M size gobo into the holder from the motor side. If gobo has a toward source side, it should go in down, away from the motor.
- Step 3. Align the image to the magnet on the carrier
- Step 4. Install the gobo spacer over the gobo
- Step 5. Install the retaining spring over the spacer. Ensure it locks into place.
- Step 6. Remove the front cover as described earlier

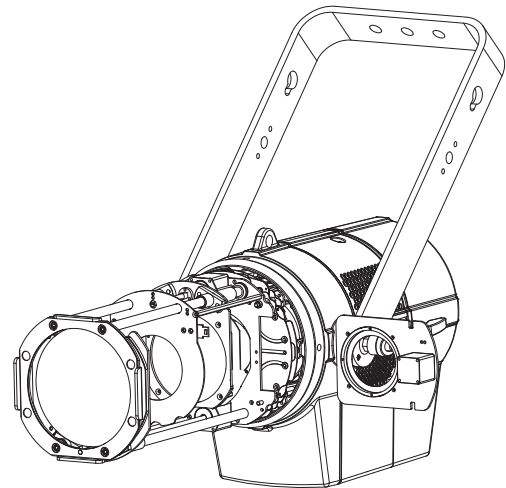
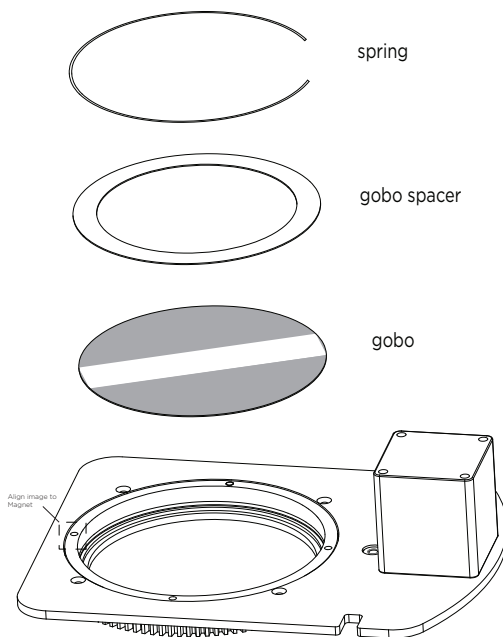

- Step 7. Insert the rotating gobo assembly into the fixture, with the motor facing toward the front.
- Step 8. Connect the wiring harness
- Step 9. Ensure the wiring is secured out of the way of any moving parts
- Step 10. Replace the front cover as described above.

NOTE: If there is no Gobo Rotator Assembly installed, the unit will show a gobo error on power up. This is normal and can be ignored. However, if the Gobo Rotator Assembly is installed and the error is shown, it should be treated as a real error message.

3 MENU OPERATION

CONTROL PANEL

Press the MENU button to select any functions, until the required function is shown in the display. Select the desired function by pressing ENTER, which will cause the display to blink. Use the UP and DOWN button to change the mode. Once the required mode has been selected, press the ENTER button to accept the selection. Press MENU to return to the previous menu or let the unit idle for one minute to exit menu mode automatically.

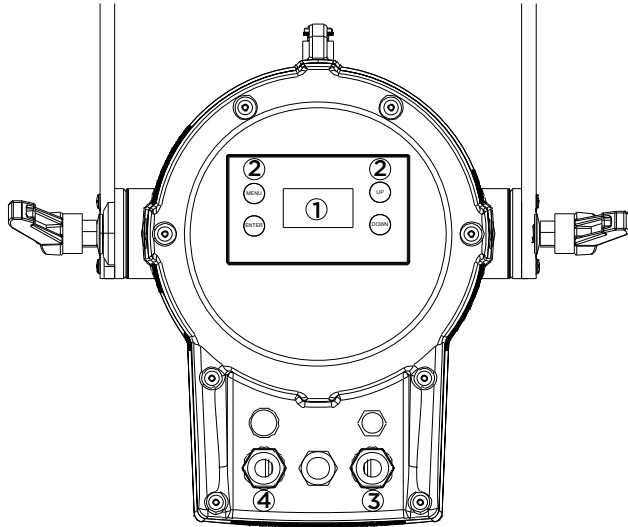

- ① **LCD display** - shows the menu and selected functions
- ② **Control buttons**
 - MENU - use to select programming functions
 - ENTER - use to confirm selected functions
 - UP - toggle forward through functions
 - DOWN - toggle backward through functions
- ③ **DMX in** - 5-pin XLR cable to link DMX console
DMX out - 5-pin XLR cable to link to next fixture
- ④ **Power in** - connects to power supply

UNLOCKING THE DISPLAY

The display on the IP Image Projecting Profile is designed to be locked to prevent unauthorized changes to the setting. To unlock the display:

- Step 1. Touch and hold the MENU button for approximately 10 seconds.
- Step 2. When prompted for the passcode, touch the UP button, then the DOWN button, then the UP button, then the DOWN button and finally ENTER.
- Step 3. The display will unlock

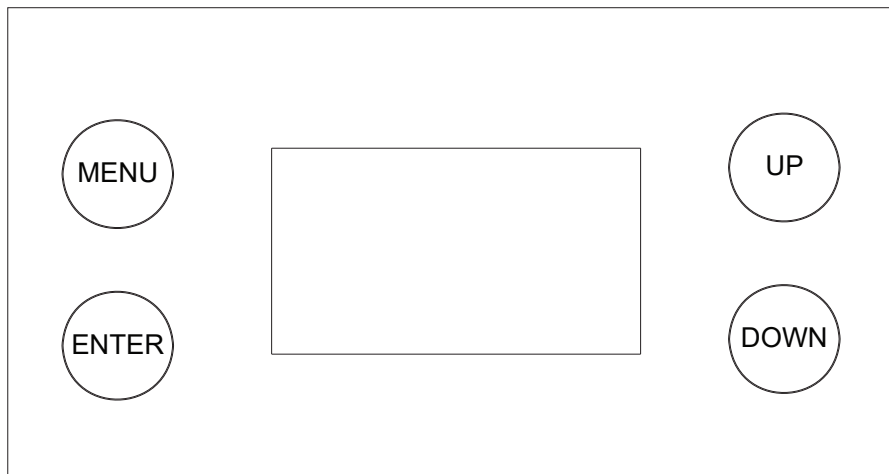

TABLE 1. MENU FUNCTIONS

LEVEL 1	LEVEL 2	LEVEL 3	LEVEL 4	LEVEL 5	LEVEL 6	DEFAULT		
Address	001 - 494 SSSC	001 - 503 SSQC	001 - 490 SSOC			001		
Configure	LED	LED Hours	XXXXXX h					
		Reset LED Hour	Are you sure?					
		Dimming Curve	Square Curve				(Default)	
			S Curve					
			Linear Curve					
		Tungsten Fade	On					
			Off				(Default)	
		Dim Snap	On (Fast)					
			Off (Slow)				(Default)	
		LED Frequency	1200Hz				(Default)	
			2500Hz					
			5000Hz					
			10000Hz					
			20000Hz					
			25000Hz					
		White Balance	Red		125 - 255			Default 255
			Green		125 - 255			Default 255
	Blue			125 - 255			Default 255	
	Amber			125 - 255			Default 255	
	Lime			125 - 255			Default 255	
	Cyan			125 - 255			Default 255	
	Reset			YES/NO				
	Color Cal		On					
		Off					(Default)	
	Disp Timeout	30 Sec					(Default)	
		5 Min						
		10 Min						
On								
Reset	Yes / No							
DMX	Address	001 - 494 SSSC	001 - 503 SSQC	001 - 490 SSOC				
	DMX Mode	SSCC				(Default)		
		SQCC						
		SOCC						
	Pixel Group	Group 1				(Default)		
		Group 2						
	DMX Fail	Hold				(Default)		
		Blackout						
		Go to Preset						
	Data	Ch 1 - Intensity XXX (Value)						
Ch 2 - Intensity Fine XXX (Value)								
.....All functions								
Select Signal	DMX Only					(Default)		
	Wdmx		Con/Discon...					

TABLE 1. MENU FUNCTIONS

LEVEL 1	LEVEL 2	LEVEL 3	LEVEL 4	LEVEL 5	LEVEL 6	DEFAULT	
Fixture	Serial Number	Serial Number electronic format					
	Status	(No Errors... or displays a list of errors)					
	Reboot Fixture	Are you sure?					
	Version	VXXX		MM/D/YY	HH:MM		
	Fixture Hours	XXXXXX h					
	Crossload (Software)	Send					
	Service	Diagnostics	Board Check Sensor Check				
Manual Preset	Preset Run	Power Up Preset	001 - 020				
		Intensity	000 - 255			255	
		Priority	Preset				(Default)
			DMX				
	Power Up	Off				(Default)	
		On					
	Edit Programs	Edit Settings	Load Preset	001 - 020			
			Intensity	000 - 255			
			Strobe	000 - 255			
			Color Preset	000 - 255			
			Red	000 - 255			
			Green	000 - 255			
			Blue	000 - 255			
			Amber	000 - 255			
			Lime	000 - 255			
			Cyan	000 - 255			
			Zoom	000 - 255			
			Focus	000 - 255			
			Gobo Index	000 - 255			
			Gobo Mode	000 - 255			
Store	001 - 020	YES/NO					
Clear	001 - 020	YES/NO					
Clear All Presets	YES/NO						

MENU SYSTEM

DISPLAY AND MENU SYSTEM OPERATION

The Display Menu system consists of several categories. Use the Menu Button to access the menu. Then use the Up/Down arrow to navigate. When you reach the desired item, touch the Enter Button. To go backwards, touch the Menu Button.

To navigate and access menu settings/selections:

- Step 1. Make sure unit is powered and turned on.
- Step 2. Touch [MENU] to access menu categories.
- Step 3. Use two Arrow (▲▼) buttons to navigate through the various options and settings.
- Step 4. Once menu item is reached, touch [ENTER] to access the menu item parameters.
- Step 5. Make changes to parameters as desired.
- Step 6. Press [ENTER] button to accept changes.

ADDRESS

ADDRESS

Sets the starting DMX address for the fixture. Can also be set via RDM.

CONFIGURE

LED

This menu allows for viewing the LED engine hours, setting the dimming curve, tungsten fade, dim snap, output mode, fan mode, LED frequency and white balance.

LED Hours

Displays the current LED engine hours.

Reset LED Hours

Allows the LED hours of the engine to be reset. Should only be done if the engine has been replaced

Dimming Curve

Select from Linear, S-Curve and Square Law. Can also be set via the control channel and RDM.

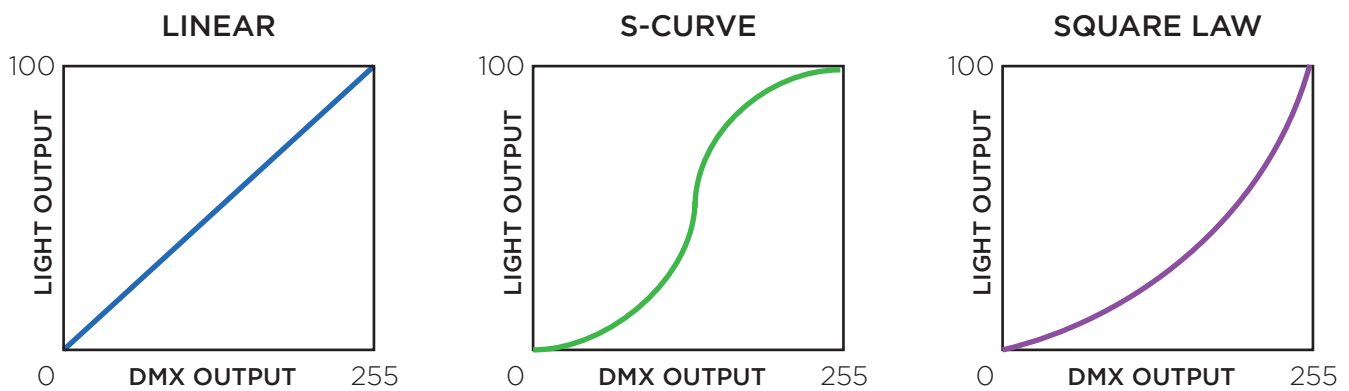

Tungsten Fade

Tungsten fade on will simulate the red shift of a tungsten lamp while dimming. Will only function in SSCC mode with a CCT setting of 3200 °K.

Dim Snap

Dim Snap On allows for fastest output changes between levels but reduces smoothness dimming the LED engine. Dim Snap Off ensures all fades between output levels remains smooth and flicker free but limits fast, instant snaps between levels. Can also be set via the control channel and RDM.

LED Frequency

Choose the refresh rate of the LED engine (see Display Menu Tree for list).

White Balance

Allows for the fine tuning of the 'white' output by adjusting the individual levels of Red, Green, Blue, Amber, Lime, and Cyan.

COLOR CAL

Enabling color calibration allows greater consistency and usefulness of the 'white' output. Disabling allows for the greatest color control.

DISPLAY TIMEOUT

Sets how long the display remains illuminated after the last button touch. Choose from 30 seconds, 5 minutes, 10 minutes, or always on.

RESET

Resets all the factory defaults of the fixture. This includes setting the DMX Address to 001. Can also be done via RDM and via the control channel.

NOTE: Control channel will not change the current DMX address.

DMX

ADDRESS

Sets the starting DMX address of the fixture. Can also be set via RDM.

DMX MODE

SSCC

Strand Smart Color Control - allows the luminaire to be used as a traditional subtractive color mixing (CMY) fixture. The base white color temperature can be adjusted using the CCT channel.

SQCC

Strand Quick Color Control - allows for simple access of colors via the preset color channel only.

SOCC

Strand Opensource Color Control - allows full access of the Red, Green, Blue, Amber, Lime, and Cyan LEDs for complete control over the color mix.

DMX FAIL

DMX Hold

If DMX is lost, fixture will maintain its present state until DMX is restored.

Blackout

If DMX is lost, fixture will go to blackout until DMX is restored.

Goto Preset

If DMX is lost, fixture will go to the preset (1 through 20).

DATA

Allows the current DMX value present on each of the luminaire's DMX channels to be viewed.

SELECT SIGNAL

DMX Only

Fixture responds only to physical DMX/RDM input.

Wdmx

Fixture can be paired with a Wireless Solutions WDMX transmitter. After choosing Wdmx, fixture will go into pair mode and will connect with transmitter in pair mode.

NOTE: Wireless Solutions WDMX transmitter supplied by others. Refer to their user manual for instructions to operate transmitter

FIXTURE

UID

Displays the UID as set in the luminaire.

STATUS

Shows list of error message from previous calibration. If none, it will say No Errors.

REBOOT FIXTURE

Restarts the entire operating system of the fixture. Can be performed via the control channel or RDM.

VERSION

Shows the current software version of the fixture. Version is listed in MM/DD/YY format. Can be viewed via RDM.

FIXTURE HOURS

Shows the accumulated hours the fixture has been powered on. Can be viewed via RDM.

CROSSLLOAD (SOFTWARE)

Allows the current version of software installed in the fixture to be sent to other units via an attached DMX cable.

SERVICE - DIAGNOSTICS

Board Check

Shows the current status of the control board.

Sensor Check

Shows the current temp at the LED in °C.

MANUAL PRESET

PLAYBACK

Power Up Preset

Selects the preset (1 to 20) that will be played back after power up if enabled.

Intensity

Selects the master intensity of a preset being played back (0 to 255).

Priority

Choose Preset if you always want a preset to playback. Choose DMX if you only want a preset to playback if there is no DMX present.

Power Up?

Choose Preset On if you want the fixture to playback the preset at power up. Choose Preset Off if you do not want a preset to play.

EDIT PROGRAMS

Load Preset

Select from preset 1 to 20 and touch [ENTER]. That preset will be played back.

Edit Settings

Choose the function from the list you wish to edit and touch [ENTER]. Use the [UP]/[DOWN] buttons to set desired value. Touch [ENTER] to store. Then continue to adjust all function desired.

Store

After setting all your functions, select which preset number you wish to store (1 to 20) and touch [ENTER]. Touch [ENTER] again to confirm when prompted.

Clear

Select the preset (1 to 20) you wish to clear and touch [ENTER]. Touch [ENTER] again to confirm when prompted.

Clear All Presets

When prompted, touch [ENTER] to confirm and all presets (1 to 20) will be erased.

WARNING: Clearing the presets CANNOT be undone!

Presets can also be stored via a DMX controller using the control channel.

4 DMX MAPPING

The fixture can be operated by DMX controller. The following tables assumes a DMX start address of 1. When a different starting address is used, this address becomes channel 1 function and other functions follow in sequence.

TABLE 1. SSCC

DMX CHANNEL	PARAMETER	DEFAULTS	RANGE DMX	DESCRIPTION
1	Intensity (High)	0	0 - 65535	16-bit Intensity (Dimmer) Control 0 - 100% Output
2	Intensity (Low)			
3	Strobe	0	0 - 255	Strobe S>>>>>F
			0 - 9	No Strobe Function - Shutter open
			10 - 99	Strobe S>>>>>F
			100 - 109	No Strobe Function - Shutter open
			110 - 179	Lighting Strobe S>>>>>F
			180 - 189	No Strobe Function - Shutter open
			190 - 255	Random Strobe S>>>>>F
4	Color Preset	0	0 - 255	Calibrated color presets 01 to 33 User definable color preset 01 to 20
			0 - 10	Channel OFF Color Mixing take priority
			11 - 14	Moroccan Pink
			15 - 18	Pink
			19 - 22	Flesh Pink
			23 - 26	Bright Rose
			27 - 30	Follies Pink
			31 - 34	Fuchsia Pink
			35 - 38	Surprise Pink
			39 - 42	Congo Blue
			43 - 46	Blue
			47 - 50	Virgin Blue
			51 - 54	Midnight Maya
			55 - 58	Double C.T Blue
			59 - 62	Slate Blue
			63 - 66	Regal Blue
			67 - 70	Full C.T Blue
			71 - 74	Steel Blue
			75 - 78	Lighter Blue
			79 - 82	Cyan
			83 - 86	Marine Blue
			87 - 90	Soft Green
			91 - 94	Moss Green
95 - 98	Green			
99 - 102	Fem Green			
103 - 106	JAS Green			
107 - 110	Pale Green			
111 - 114	Spring Yellow			

TABLE 1. SSCC

DMX CHANNEL	PARAMETER	DEFAULTS	RANGE DMX	DESCRIPTION
4	Color Preset continued	0	115 - 118	Yellow
			119 - 122	Deep Amber
			123 - 126	Chrome Orange
			127 - 130	Orange
			131 - 134	Magenta
			135 - 138	Flame Red
			139 - 142	Purple
			143 - 146	User Preset 1 Includes Intensity, Gobo and Edge Data
			147 - 150	User Preset 2 Includes Intensity, Gobo and Edge Data
			151 - 154	User Preset 3 Includes Intensity, Gobo and Edge Data
			155 - 158	User Preset 4 Includes Intensity, Gobo and Edge Data
			159 - 162	User Preset 5 Includes Intensity, Gobo and Edge Data
			163 - 166	User Preset 6 Includes Intensity, Gobo and Edge Data
			167 - 170	User Preset 7 Includes Intensity, Gobo and Edge Data
			171 - 174	User Preset 8 Includes Intensity, Gobo and Edge Data
			175 - 178	User Preset 9 Includes Intensity, Gobo and Edge Data
			179 - 182	User Preset 10 Includes Intensity, Gobo and Edge Data
			183 - 186	User Preset 11 Includes Intensity, Gobo and Edge Data
			187 - 190	User Preset 12 Includes Intensity, Gobo and Edge Data
			191 - 194	User Preset 13 Includes Intensity, Gobo and Edge Data
			195 - 198	User Preset 14 Includes Intensity, Gobo and Edge Data
			199 - 202	User Preset 15 Includes Intensity, Gobo and Edge Data
			203 - 206	User Preset 16 Includes Intensity, Gobo and Edge Data
207 - 210	User Preset 17 Includes Intensity, Gobo and Edge Data			
211 - 214	User Preset 18 Includes Intensity, Gobo and Edge Data			
215 - 218	User Preset 19 Includes Intensity, Gobo and Edge Data			
219 - 222	User Preset 20 Includes Intensity, Gobo and Edge Data			
223 - 255	Channel OFF Color Mixing take priority			
5	Zoom	128	0 - 255	8 Bit Motorized Zoom control 0 - 100% 0 = 15° 100% = 30°
6	Focus (High)	32767	0 - 65535	16-bit Motorized Focus control
7	Focus (Low)			
8	Gobo Index (High)	32767	0 - 65535	Gobo Index / Rotation Switched mode via channel 10
9	Gobo Index (Low)		32780 - 65535	Clockwise Index / Rotation S>>>>>>F
			32754 - 32780	Stop
		0 - 32754	Counter Clockwise Index / Rotation S>>>>>>F	
10	Gobo Mode	0	0 - 255	Gobo Index/ Rotation Mode Control
			0 - 50	Gobo Index Mode
			51 - 100	Gobo Rotation Mode
			101 - 255	Reserved Values

TABLE 1. SSCC

DMX CHANNEL	PARAMETER	DEFAULTS	RANGE DMX	DESCRIPTION
11	Control Channel	0	0 - 255	Control Channel used for full fixture settings, lamp controls, and miscellaneous modes. Set discrete value of desired effect, wait >3 seconds, then set value to 0 (Idle). **Function does not require 3 Second rule to active, setting output to value will automatically activate function
			0 - 5	Idle (Default)
			6 - 10	Full Luminaire ReCal - Also Used to Wake fixture up from shutdown
			11 - 15	Fixture Shutdown
			16 - 20	Reserved Values
			21 - 25	Display - Menu ON
			26 - 30	Display - Menu OFF
			31 - 35	Tungsten Dimming On**
			36 - 40	Tungsten Dimming Off (Default)**
			41 - 45	Dimming Curve Linear**
			46 - 50	Dimming Curve S-Curve**
			51 - 55	Dimming Curve Square Curve (Default)**
			56 - 60	Reserved
			61 - 65	Dimmer Snap On**
			66 - 70	Dimmer Snap Off (Default)**
			71 - 150	Reserved Values
			151 - 155	Record User Color Preset**
			156 - 170	Reserved Values
171 - 175	Reset fixture to default			
176 - 255	Reserved Values			
12	Cyan (High)	0	0 - 65535	Cyan Color Level Control 0 - 100% Saturation
13	Cyan (Low)			6 Color LED array auto adjust to meet Cyan / mixed color point of full available color spectrum
14	Yellow (High)	0	0 - 65535	Yellow Color Level Control 0 - 100% Saturation
15	Yellow (Low)			6 Color LED array auto adjust to meet Yellow / mixed color point of full available color spectrum
16	Magenta (High)	0	0 - 65535	Magenta Color Level Control 0 - 100% Saturation
17	Magenta (Low)			6 Color LED array auto adjust to meet Magenta / mixed color point of full available color spectrum

TABLE 1. SSCC

DMX CHANNEL	PARAMETER	DEFAULTS	RANGE DMX	DESCRIPTION
18	CCT	75	0 - 250	Variable color temperature control channel Channel works independent of color mixing channel and will adjust all mixed color from selected color temperature level. Values stated below are a for guidance only channel should be mapped in such away that channel level runs variable from 0 - 250
			0	1800K
			25	2700K
			50	3000K
			75	3200K (Default)
			100	4000K
			125	4500K
			150	5000K
			175	5600K
			200	6500K
			225	8000K
			250	10000K
			250 - 255	Reserved Hold 10000K
19	Green Shift	0	0 - 255	TV Camera Green Shift adjustment Channel works independent of color mixing channel and will adjust all mixed color from to reduce green color for camera use 0 to -100% Minus Green Levels 100% = to Lee Filter Full minus Green 247

TABLE 2. SQCC

DMX CHANNEL	PARAMETER	DEFAULTS	RANGE DMX	DESCRIPTION
1	Intensity (High)	0	0 - 65535	16bit Intensity (Dimmer) Control
2	Intensity (Low)			0 - 100% Output
3	Strobe	0	0 - 255	Strobe S>>>>>F
			0 - 9	No Strobe Function - Shutter open
			10 - 99	Strobe S>>>>>F
			100 - 109	No Strobe Function - Shutter open
			110 - 179	Lighting Strobe S>>>>>F
			180 - 189	No Strobe Function - Shutter open
190 - 255	Random Strobe S>>>>>F			

TABLE 2. SQCC

DMX CHANNEL	PARAMETER	DEFAULTS	RANGE DMX	DESCRIPTION
4	Color Preset	0	0 - 255	Calibrated color presets 01 to 33 User definable color preset 01 to 20
			0 - 10	Channel OFF Color Mixing take priority
			11 - 14	Moroccan Pink
			15 - 18	Pink
			19 - 22	Flesh Pink
			23 - 26	Bright Rose
			27 - 30	Follies Pink
			31 - 34	Fuchsia Pink
			35 - 38	Surprise Pink
			39 - 42	Congo Blue
			43 - 46	Blue
			47 - 50	Virgin Blue
			51 - 54	Midnight Maya
			55 - 58	Double C.T Blue
			59 - 62	Slate Blue
			63 - 66	Regal Blue
			67 - 70	Full C.T Blue
			71 - 74	Steel Blue
			75 - 78	Lighter Blue
			79 - 82	Cyan
			83 - 86	Marine Blue
			87 - 90	Soft Green
			91 - 94	Moss Green
			95 - 98	Green
			99 - 102	Fem Green
			103 - 106	JAS Green
			107 - 110	Pale Green
			111 - 114	Spring Yellow
			115 - 118	Yellow
			119 - 122	Deep Amber
123 - 126	Chrome Orange			
127 - 130	Orange			
131 - 134	Magenta			
135 - 138	Flame Red			
139 - 142	Purple			
143 - 146	User Preset 1 Includes Intensity, Gobo and Edge Data			
147 - 150	User Preset 2 Includes Intensity, Gobo and Edge Data			

TABLE 2. SQCC

DMX CHANNEL	PARAMETER	DEFAULTS	RANGE DMX	DESCRIPTION
4	Color Preset continued	0	151 - 154	User Preset 3 Includes Intensity, Gobo and Edge Data
			155 - 158	User Preset 4 Includes Intensity, Gobo and Edge Data
			159 - 162	User Preset 5 Includes Intensity, Gobo and Edge Data
			163 - 166	User Preset 6 Includes Intensity, Gobo and Edge Data
			167 - 170	User Preset 7 Includes Intensity, Gobo and Edge Data
			171 - 174	User Preset 8 Includes Intensity, Gobo and Edge Data
			175 - 178	User Preset 9 Includes Intensity, Gobo and Edge Data
			179 - 182	User Preset 10 Includes Intensity, Gobo and Edge Data
			183 - 186	User Preset 11 Includes Intensity, Gobo and Edge Data
			187 - 190	User Preset 12 Includes Intensity, Gobo and Edge Data
			191 - 194	User Preset 13 Includes Intensity, Gobo and Edge Data
			195 - 198	User Preset 14 Includes Intensity, Gobo and Edge Data
			199 - 202	User Preset 15 Includes Intensity, Gobo and Edge Data
			203 - 206	User Preset 16 Includes Intensity, Gobo and Edge Data
			207 - 210	User Preset 17 Includes Intensity, Gobo and Edge Data
			211 - 214	User Preset 18 Includes Intensity, Gobo and Edge Data
			215 - 218	User Preset 19 Includes Intensity, Gobo and Edge Data
219 - 222	User Preset 20 Includes Intensity, Gobo and Edge Data			
223 - 255	Channel OFF Color Mixing take priority			
5	Zoom	128	0 - 255	8 Bit Motorized Zoom control 0 - 100% 0 = 15° 100% = 30°
6	Focus (High)	32767	0 - 65535	16 Bit Motorized Focus control
7	Focus (Low)			
8	Gobo Index (High)	32767	0 - 65535	Gobo Index / Rotation Switched mode via channel 10
9	Gobo Index (Low)		32780 - 65535	Clockwise Index / Rotation S>>>>>>F
			32754 - 32780	Stop
		0 - 32754	Counter Clockwise Index / Rotation S>>>>>>F	
10	Gobo Mode	0	0 - 255	Gobo Index/ Rotation Mode Control
			0 - 50	Gobo Index Mode
			51 - 100	Gobo Rotation Mode
			101 - 255	Reserved Values

TABLE 3. SOCC

DMX CHANNEL	PARAMETER	DEFAULTS	RANGE DMX	DESCRIPTION
1	Intensity (High)	0	0 - 65535	16bit Intensity (Dimmer) Control
2	Intensity (Low)			0 - 100% Output
3	Strobe	0	0 - 255	Strobe S>>>>>F
			0 - 9	No Strobe Function - Shutter open
			10 - 99	Strobe S>>>>>F
			100 - 109	No Strobe Function - Shutter open
			110 - 179	Lighting Strobe S>>>>>F
			180 - 189	No Strobe Function - Shutter open
			190 - 255	Random Strobe S>>>>>F

TABLE 3. SOCC

DMX CHANNEL	PARAMETER	DEFAULTS	RANGE DMX	DESCRIPTION
4	Color Preset	0	0 - 255	Calibrated color presets 01 to 33 User definable color preset 01 to 20
			0 - 10	Channel OFF Color Mixing take priority
			11 - 14	Moroccan Pink
			15 - 18	Pink
			19 - 22	Flesh Pink
			23 - 26	Bright Rose
			27 - 30	Follies Pink
			31 - 34	Fuchsia Pink
			35 - 38	Surprise Pink
			39 - 42	Congo Blue
			43 - 46	Blue
			47 - 50	Virgin Blue
			51 - 54	Midnight Maya
			55 - 58	Double C.T Blue
			59 - 62	Slate Blue
			63 - 66	Regal Blue
			67 - 70	Full C.T Blue
			71 - 74	Steel Blue
			75 - 78	Lighter Blue
			79 - 82	Cyan
			83 - 86	Marine Blue
			87 - 90	Soft Green
			91 - 94	Moss Green
			95 - 98	Green
			99 - 102	Fem Green
			103 - 106	JAS Green
			107 - 110	Pale Green
			111 - 114	Spring Yellow
			115 - 118	Yellow
			119 - 122	Deep Amber
123 - 126	Chrome Orange			
127 - 130	Orange			
131 - 134	Magenta			
135 - 138	Flame Red			
139 - 142	Purple			
143 - 146	User Preset 1 Includes Intensity, Gobo and Edge Data			
147 - 150	User Preset 2 Includes Intensity, Gobo and Edge Data			

TABLE 3. SOCC

DMX CHANNEL	PARAMETER	DEFAULTS	RANGE DMX	DESCRIPTION
4	Color Preset continued	0	151 - 154	User Preset 3 Includes Intensity, Gobo and Edge Data
			155 - 158	User Preset 4 Includes Intensity, Gobo and Edge Data
			159 - 162	User Preset 5 Includes Intensity, Gobo and Edge Data
			163 - 166	User Preset 6 Includes Intensity, Gobo and Edge Data
			167 - 170	User Preset 7 Includes Intensity, Gobo and Edge Data
			171 - 174	User Preset 8 Includes Intensity, Gobo and Edge Data
			175 - 178	User Preset 9 Includes Intensity, Gobo and Edge Data
			179 - 182	User Preset 10 Includes Intensity, Gobo and Edge Data
			183 - 186	User Preset 11 Includes Intensity, Gobo and Edge Data
			187 - 190	User Preset 12 Includes Intensity, Gobo and Edge Data
			191 - 194	User Preset 13 Includes Intensity, Gobo and Edge Data
			195 - 198	User Preset 14 Includes Intensity, Gobo and Edge Data
			199 - 202	User Preset 15 Includes Intensity, Gobo and Edge Data
			203 - 206	User Preset 16 Includes Intensity, Gobo and Edge Data
			207 - 210	User Preset 17 Includes Intensity, Gobo and Edge Data
			211 - 214	User Preset 18 Includes Intensity, Gobo and Edge Data
			215 - 218	User Preset 19 Includes Intensity, Gobo and Edge Data
219 - 222	User Preset 20 Includes Intensity, Gobo and Edge Data			
223 - 255	Channel OFF Color Mixing take priority			
5	Zoom	128	0 - 255	8 Bit Motorized Zoom control 0 - 100% 0 = 15° 100% = 30°
6	Focus (High)	32767	0 - 65535	16 Bit Motorized Focus control
7	Focus (Low)			
8	Gobo Index (High)	32767	0 - 65535	Gobo Index / Rotation Switched mode via channel 10
9	Gobo Index (Low)		32780 - 65535	Clockwise Index / Rotation S>>>>>>F
			32754 - 32780	Stop
		0 - 32754	Counter Clockwise Index / Rotation S>>>>>>F	
10	Gobo Mode	0	0 - 255	Gobo Index/ Rotation Mode Control
			0 - 50	Gobo Index Mode
			51 - 100	Gobo Rotation Mode
			101 - 255	Reserved Values

TABLE 3. SOCC

DMX CHANNEL	PARAMETER	DEFAULTS	RANGE DMX	DESCRIPTION
11	Control Channel	0	0 - 255	Control Channel used for full fixture settings, lamp controls, and miscellaneous modes. Set discrete value of desired effect, wait >3 seconds, then set value to 0 (Idle). **Function does not require 3 Second rule to active, setting output to value will automatically activate function
			0 - 5	Idle (Default)
			6 - 10	Full Luminaire ReCal - Also Used to Wake fixture up from shutdown
			11 - 15	Fixture Shutdown
			16 - 20	Reserved Values
			21 - 25	Display - Menu ON
			26 - 30	Display - Menu OFF
			31 - 35	Tungsten Dimming On**
			36 - 40	Tungsten Dimming Off (Default)**
			41 - 45	Dimming Curve Linear**
			46 - 50	Dimming Curve S-Curve**
			51 - 55	Dimming Curve Square Curve (Default)**
			56 - 60	Reserved
			61 - 65	Dimmer Snap On**
			66 - 70	Dimmer Snap Off (Default)**
			71 - 150	Reserved Values
			151 - 155	Record User Color Preset**
			156 - 170	Reserved Values
			171 - 175	Reset fixture to default
176 - 255	Reserved Values			
12	Red (High)	0	0 - 65535	Red Color Level Control 0 - 100% Saturation
13	Red (Low)			
14	Green (High)	0	0 - 65535	Green Color Level Control 0 - 100% Saturation
15	Green (Low)			
16	Blue (High)	0	0 - 65535	Blue Color Level Control 0 - 100% Saturation
17	Blue (Low)			
18	Amber (High)	0	0 - 65535	Amber Color Level Control 0 - 100% Saturation
19	Amber (Low)			
20	Lime (High)	0	0 - 65535	Lime Color Level Control 0 - 100% Saturation
21	Lime (Low)			
22	Cyan (High)	0	0 - 65535	Cyan Color Level Control 0 - 100% Saturation
23	Cyan (Low)			

TABLE 4. COLOR PRESETS

RANGE DMX	COLOR	RANGE DMX	COLOR
0 - 255	Calibrated color presets 01 to 33	115 - 118	Yellow
	User definable color preset 01 to 20	119 - 122	Deep Amber
0 - 10	Channel OFF Color Mixing take priority	123 - 126	Chrome Orange
11 - 14	Moroccan Pink	127 - 130	Orange
15 - 18	Pink	131 - 134	Magenta
19 - 22	Flesh Pink	135 - 138	Flame Red
23 - 26	Bright Rose	139 - 142	Purple
27 - 30	Follies Pink	143 - 146	User Preset 1
31 - 34	Fuchsia Pink	147 - 150	User Preset 2
35 - 38	Surprise Pink	151 - 154	User Preset 3
39 - 42	Congo Blue	155 - 158	User Preset 4
43 - 46	Blue	159 - 162	User Preset 5
47 - 50	Virgin Blue	163 - 166	User Preset 6
51 - 54	Midnight Maya	167 - 170	User Preset 7
55 - 58	Double C.T Blue	171 - 174	User Preset 8
59 - 62	Slate Blue	175 - 178	User Preset 9
63 - 66	Regal Blue	179 - 182	User Preset 10
67 - 70	Full C.T Blue	183 - 186	User Preset 11
71 - 74	Steel Blue	187 - 190	User Preset 12
75 - 78	Lighter Blue	191 - 194	User Preset 13
79 - 82	Cyan	195 - 198	User Preset 14
83 - 86	Marine Blue	199 - 202	User Preset 15
87 - 90	Soft Green	203 - 206	User Preset 16
91 - 94	Moss Green	207 - 210	User Preset 17
95 - 98	Green	211 - 214	User Preset 18
99 - 102	Fem Green	215 - 218	User Preset 19
103 - 106	JAS Green	219 - 222	User Preset 20
107 - 110	Pale Green	223 - 255	Channel OFF Color Mixing take priority
111 - 114	Spring Yellow		

TABLE 5. CCT CHANNEL

DMX CHANNEL	DEFAULT	RANGE DMX	FUNCTION
CTO	75	0 - 250	Variable color temperature control channel Channel works independent of color mixing channel and will adjust all mixed color from selected color temperature level. Values stated below are a for guidance only channel should be mapped in such away that channel level runs variable from 0 - 250
		0	1800k
		25	2700K
		50	3000K
		75	3200K (Default)
		100	4000K
		125	4500K
		150	5000K
		175	5600K
		200	6500K
		225	8000K
		250	10000K
		250 - 255	Reserved Hold 10000K

TABLE 6. GREEN SHIFT CHANNEL

DMX CHANNEL	DEFAULT	RANGE DMX	FUNCTION
Green Shift	100	0 - 250	TV Camera Green Shift adjustment Channel works independently of color mixing channel and will adjust all mixed color from to reduce green color for camera use 0 to -100% Minus Green Levels 100% = to Lee Filter Full minus Green 247
		0 - 10	No Function
		11 - 29	Full Minus Green
		30 - 69	-99% to -1% Green
		70 - 129	No Function
		130 - 189	+1% to +99% Green
		190 - 255	Full Plus Green

TABLE 7. CONTROL CHANNEL

RANGE DMX	ITEMS	DESCRIPTION	POWER CYCLE RULES	FUNCTION SELECTION VIA UI
0 - 255	Control Channel	Control Channel used for full fixture settings, lamp controls, and miscellaneous modes. Set discrete value of desired effect, wait >3 seconds, then set value to 0 (Idle). **Function does not require 3 Second rule to active, setting output	N/A	N/A
0 - 5	Idle (Default)	Default value used as return point to activate all control functions	N/A	N/A
6 - 10	Full Luminaire ReCal -	Recalibrates all mechanical functions and sensor with in the fixture. Also Used to Wake fixture up from shutdown	N/A	
11 - 15	Fixture Shutdown	Shuts down all fixture output and turns off all fans - fixture is activated by power cycle or ReCal command	If fixture is powered down then up fixture will auto wake and not startup in Shutdown Mode	N/A
16 - 20	Reserved Values		N/A	N/A
21 - 25	Display - Menu ON	Switches UI display backlight on remotely - Display will Time out from on after 5 mins	N/A	N/A
26 - 30	Display - Menu OFF		N/A	N/A
31 - 35	Tungsten Dimming On**	Remote switches Tungsten Dimming color shift on	Holds setting on power cycle	Yes
36 - 40	Tungsten Dimming Off (Default)**	Remote switches Tungsten Dimming color shift off	Holds setting on power cycle	Yes
41 - 45	Dimming Curve Linear**	Selects Linear Dimming Curve, Also Used to Wake fixture up from shutdown	Holds setting on power cycle	Yes
46 - 50	Dimming Curve S-Curve**	Selects S-Law Dimming Curve	Holds setting on power cycle	Yes
51 - 55	Dimming Curve Square Law (Default)**	Selects Square -Law Dimming Curve	Holds setting on power cycle	Yes
56 - 60	Reserved Values			
61 - 65	Dimmer Snap On**	Allows for fastest output changes between levels but reduces smoothness dimming LED	Holds setting on power cycle	Yes
66 - 70	Dimmer Snap Off (Default)**	Ensures all fades between output levels remain smooth and flicker free limits fast instant snaps between levels	Holds setting on power cycle	Yes
71 - 90	Reserved Values		N/A	N/A
91 - 95	Color Calibration on	Turns Color calibration on for fixture to fixture color matching on all mixed and preset colors between fixtures limits highest output and max saturation on some colors	Holds setting on power cycle	Yes
96 - 100	Color Calibration off (Default)	Turns Color calibration off fixtures may not match fixture to fixture limits fast instant snaps between levels	Holds setting on power cycle	Yes
101 - 150	Reserved Values		N/A	N/A
151 - 155	Record User Color Preset**	Takes Current Color mixing values and stores to next available blank User color preset - if preset listing are full preset will not record. User will need to clear preset via fixture UI	N/A	N/A
156 - 170	Reserved		N/A	N/A
171 - 175	Reset fixture to default	Will reset all parameters to default with the exception of the Mx address, fixture mode and Pixel / Zone selection	N/A	Yes - Will reset DMX address, Mode
176 - 255	Reserved		N/A	N/A

DMX512 CONNECTION

- At last unit, the DMX cable has to be terminated with a terminator. Solder a 120Ω 1/4W resistor between pin 2(DMX-) and pin 3(DMX+) into a 5-pin XLR-plug and plug it in the DMX-output of the last unit.
- Connect the unit together in a `daisy chain` by XLR plug from the output of the unit to the input of the next unit. The cable cannot branched or split to a `Y` cable. DMX 512 is a very high-speed signal. Inadequate or damaged cables, soldered joints or corroded connectors can easily distort the signal and shut down the system.
- The DMX output and input connectors are pass-through to maintain the DMX circuit, when one of the units' power is disconnected.
- Each lighting unit needs to have an address set to receive the data sent by the controller. The address number is between 0-511 (usually 0 & 1 are equal to 1).
- The end of the DMX 512 system should be terminated to reduce signal errors.
- 5 pin XLR: Pin 1: GND, Pin 2: Negative signal (-), Pin 3: Positive signal (+), Pin 4/Pin 5: Not used.

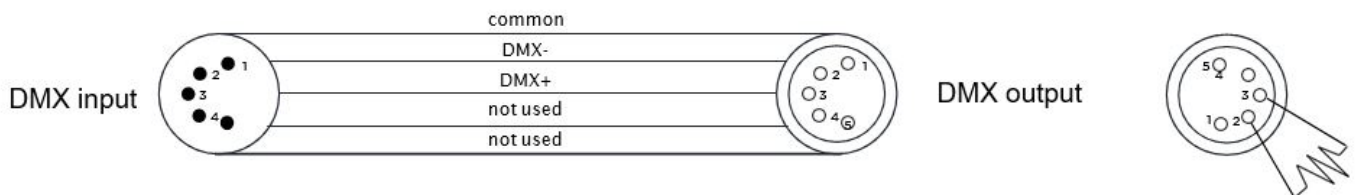
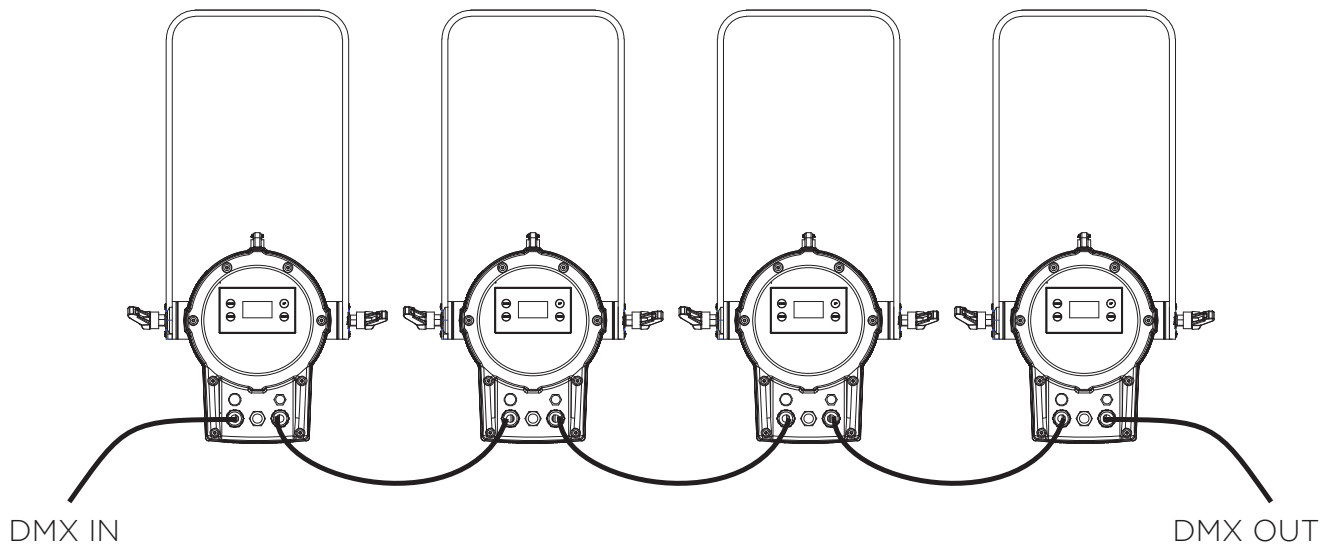

5 RDM PARAMETER IDs

Remote Device Management (RDM) is a protocol enhancement to USITT DMX512 that allows bi-directional communication between a lighting or system controller and attached RDM compliant devices over a standard DMX line. This protocol will allow configuration, status monitoring, and management of these devices in such a way that does not disturb the normal operation of standard DMX512 devices that do not recognize the RDM protocol.

LEKO LED OUTDOOR, RDM PRODUCT PARAMETER IDS				
Model ID	Manufacturer	Vendor ID	Model Description	Product Category
0x0115	Vari-Lite	0x564C	IP Image Projecting Profile, FC	0x0101

The table on the following pages outlines and describes all the RDM parameters IDs associated with the.

GET ALLOWED	SET ALLOWED	RDM PARAMETER IDS	VALUE	COMMENT	ESTA STANDARD	REQUIRED /	DMX / UI DESCRIPTION
Category - Network Management							
		DISC_UNIQUE_BRANCH	0x0001		X	X	
		DISC_MUTE	0x0002		X	X	
		DISC_UN_MUTE	0x0003		X	X	
X		PROXIED_DEVICES	0x0010				
X		PROXIED_DEVICES_COUNT	0x0011				
X	X	COMMS_STATUS	0x0015				
Category - Status Collection							
X		QUEUED_MESSAGE	0x0020				
X		STATUS_MESSAGES	0x0030			X	Status
X		STATUS_ID_DESCRIPTION	0x0031			X	
	X	CLEAR_STATUS_ID	0x0032				
X	X	SUB_DEVICE_STATUS_REPORT_THRESHOLD	0x0033				
Category - RDM Information							
X		SUPPORTED_PARAMETERS	0x0050		X	X	
X		PARAMETER_DESCRIPTION	0x0051		X	X	
Category - Product Information							
X		DEVICE_INFO	0x0060		X	X	
X		PRODUCT_DETAIL_ID_LIST	0x0070				
X		DEVICE_MODEL_DESCRIPTION	0x0080			X	
X		MANUFACTURER_LABEL	0x0081			X	
X	X	DEVICE_LABEL	0x0082			X	
X	X	FACTORY_DEFAULTS	0x0090			X	Reset Defaults
X		LANGUAGE_CAPABILITIES	0x00A0				
X	X	LANGUAGE	0x00B0				
X		SOFTWARE_VERSION_LABEL	0x00C0		X	X	Version
X		BOOT_SOFTWARE_VERSION_ID	0x00C1				
X		BOOT_SOFTWARE_VERSION_LABEL	0x00C2				
Category - DMX512 Setup							
X	X	DMX_PERSONALITY	0x00E0			X	DMX Mode
X		DMX_PERSONALITY_DESCRIPTION	0x00E1			X	
X	X	DMX_START_ADDRESS	0x00F0		X	X	Address
X		SLOT_INFO	0x0120			X	
X		SLOT_DESCRIPTION	0x0121			X	
X		DEFAULT_SLOT_VALUE	0x0122			X	
Category - Sensors 0x02xx USE							
X		SENSOR_DEFINITION	0x0200			X	
X	X	SENSOR_VALUE	0x0201	Fan Speed and		X	Diagnostics
	X	RECORD_SENSORS	0x0202				
Category - Dimmer Settings 0x03xx - FUTURE USE							
X	X	Dimmer Curve	0x0343			X	

GET ALLOWED	SET ALLOWED	RDM PARAMETER IDS	VALUE	COMMENT	ESTA STANDARD	REQUIRED /	DMX / UI DESCRIPTION
X		Dimmer Curve Description	0x0344			X	
X	X	Modulation Frequency	0x0347			X	
X		Modulation Frequency Description	0x0348			X	
Category - Power / Lamp Settings 0x04xx							
X	X	DEVICE_HOURS	0x0400			X	Fixture Hours
X	X	LAMP_HOURS	0x0401				
X	X	LAMP_STRIKES	0x0402				
X	X	LAMP_STATE	0x0403				
X	X	LAMP_ON_MODE	0x0404				
X	X	DEVICE_POWER_CYCLES	0x0405				
Category - Display Settings 0x05xx							
X	X	DISPLAY_INVERT	0x0500				
X	X	DISPLAY_LEVEL	0x0501				
Category - Configuration 0x06xx							
X	X	PAN_INVERT	0x0600				
X	X	TILT_INVERT	0x0601				
X	X	PAN_TILT_SWAP	0x0602				
X	X	REAL_TIME_CLOCK	0x0603				
Category - Control 0x10xx							
X	X	IDENTIFY_DEVICE	0x1000		X	X	
	X	RESET_DEVICE	0x1001			X	
X	X	POWER_STATE	0x1010				
X	X	PERFORM_SELFTEST	0x1020	All Test, Pan/Tilt, Encoder			
X		SELF_TEST_DESCRIPTION	0x1021				
	X	CAPTURE PRESET	0x1030	See E1-20_2010a			
X	X	PRESET PLAYBACK	0x1031	Table A-7 defines			
		ESTA Reserved Future RDM	0x7FE0-0x7FFF				
		Manufacturer-Specific PIDs	0x8000-0xFFDF				
X	X	Output Power Mode	0x8A97	Value range depends on options (Standard, Studio, etc)		X	LED Output Mode
X	X	Pan/Tilt Feedback (On/Off)	0x8AD3				
X	X	Display On Time	0x8AA0	Value range depends on options		X	Display On Time
X	X	LED Dimmer Curve	0x8AA1	Value range depends on options			LED Dimming Curve
X	X	Pan Tilt Movement (On/Off)	0x8AA2				
X	X	Head Motor Movement (On/Off)	0x8AA3				

GET ALLOWED	SET ALLOWED	RDM PARAMETER IDS	VALUE	COMMENT	ESTA STANDARD	REQUIRED /	DMX / UI DESCRIPTION
X	X	Auto Shutdown Mode	0x8AA4	Value range depends on options			
X	X	LED Hours	0x8AA5				
X	X	Dim Snap (On/Off)	0x8AA6				
X	X	Color Snap (On/Off)	0x8AA7				
X	X	Auto Fan Mode (On/Off)	0x8AA8				LED Fan Mode
X	X	Gamma Shift	0x8AA9	Value range depends on options			
X	X	Tungsten Dimming (On/Off)	0x8AAA				
X	X	CTB Correction (On/Off)	0x8AAB				
X	X	LED Refresh Rate	0x8AAC	Value range depends on options			LED Refresh Rate
X	X	Side Hang (On/Off)	0x8AAD				
X	X	Focus Track (On/Off)	0x8AAE				
	X	Control Signal select DMX only/ARTNET (On/Off)	0x8AAF				
	X	Recalibrate Fixture (Level)	0x8AB0	different levels (all, position, color, etc)			
X	X	DMX Fail (Hold, Blackout, GOTO Preset)	0x8AB1				DMX Fail
X	X	ArtNet Universe	0x8AB2				
X	X	ArtNet Net	0x8AB3				
X	X	ArtNet Sub-Net	0x8AB4				
X	X	ArtNet Ethernet IP	0x8AB5				
X	X	ArtNet Ethernet Sub-Net Mask	0x8AB6				
X	X	Manual PRESET Playback Power Up Preset	0x8AB7				
X	X	Manual PRESET Playback Preset Intensity	0x8AB8				
X	X	Manual PRESET Playback Priority	0x8AB9				
X	X	Manual PRESET Playback Power Up?	0x8ABA				
X	X	LED Color Calibration (On/Off)	0x8ABB			X	LED Color Calibration

APPENDIX A

CARE AND MAINTENANCE

TROUBLESHOOTING

The following are a few common problems that may occur during operation.

Luminaire does not work; light and fan do not turn on.

- Check power connection and main fuse.
- Measure the mains voltage on the main connector.

Not responding to DMX controller.

- If DMX LED is not illuminated, verify that the DMX cables are properly connected.
- If the DMX LED is illuminated and there is no response, verify DMX address settings and the DMX polarity.
- If you experience intermittent DMX signal problems, check the pins on the connectors or on the PCB.
- Test with a different DMX controller.
- Check if the DMX cables run near or alongside high voltage cables that may cause interference to the DMX interface circuit.

CLEANING

Cleaning the inside of the luminaire must be carried out periodically in order to optimize the light output. Cleaning frequency depends on the environment in which the fixture operates. Damp, smoky or particularly dusty surroundings can cause greater accumulation of dirt on the fixture's optics.

- Clean with a soft cloth using glass cleaning fluid.
- Dry parts carefully.
- Clean the external optics at least every 30 days.

TECHNICAL SUPPORT

GLOBAL 24HR TECHNICAL SUPPORT:

Call: +1 214 647 7880

entertainment.service@signify.com

NORTH AMERICA SUPPORT:

Call: 877-VARI-LITE (877-827-4583)

entertainment.service@signify.com

EUROPEAN CUSTOMER SERVICE CENTER:

Call: +31 (0) 543 542 531

entertainment.europe@signify.com

©2024 Signify Holding. All rights reserved.

All trademarks are owned by Signify Holding or their respective owners. The information provided herein is subject to change, without notice. Signify does not give any representation or warranty as to the accuracy or completeness of the information included herein and shall not be liable for any action in reliance thereon. The information presented in this document is not intended as any commercial offer and does not form part of any quotation or contract, unless otherwise agreed by Signify. Data subject to change.