

**PHILIPS**  
**VARI\*LITE**

## **VLZ PROFILE Luminaire**



**USER'S MANUAL**

All other brand or product names which may be mentioned in this manual are trademarks or registered trademarks of their respective companies or organizations.

The information furnished in this manual is for informational use only and is subject to change without notice. Please check <http://www.philips.com/entertainmentlighting> for latest version. Philips Vari-Lite assumes no responsibility or liability for any errors or inaccuracies that may appear in this manual. All information and graphics are property of Philips Vari-Lite, a Philips group company, 10911 Petal Street Dallas, Texas 75238 USA.

Version as of: **May 30 2017**  
Part number: **26-105-0002-00**

**VLZ PROFILE Luminaire User's Manual**  
©2013 Philips Vari-Lite, a Philips group company. All Rights Reserved.

# How To Obtain Warranty Service

A copy of the Philips Vari-Lite Limited Warranty was included in the shipping package for this VARI\***LITE** product.

To obtain warranty service, please contact customer service at 1-877-VARI-LITE (1-877-827-4548), +1-214-647-7880, or [entertainment.service@philips.com](mailto:entertainment.service@philips.com) and request a Return Material Authorization (RMA) for warranty service. You will need to provide the model and serial number of the item being returned, a description of the problem or failure and the name of the registered user or organization. If available, you should have your sales invoice to establish the date of sale as the beginning of the warranty period.

Once you obtain the RMA, pack the unit in a secure shipping container or in its original packing box. Be sure to clearly indicate the RMA number on all packing lists, correspondence, and shipping labels. If available, please include a copy of your invoice (as proof of purchase) in the shipping container. With the RMA number written legibly on or near the shipping address label, return the unit, freight prepaid, to:

Philips Vari-Lite  
Attention: Warranty Service (RMA# \_\_\_\_\_)  
10911 Petal Street  
Dallas Dallas, Texas 75238 USA  
Attention: Warranty Service

As stated in the warranty, it is required that the shipment be insured and FOB our service center.



---

---

**IMPORTANT!** When returning products to Philips Vari-Lite for repairs (warranty or out-of-warranty) from a country other than the USA, “**Philips Lighting Controls Division**”, must appear in the address block as the Importer of Record (IOR) on all shipping documentation, Commercial Invoices, etc. This must be done in order to clear customs in a timely manner and prevent returns.

---

---

# Compliance Notices

**FCC** This equipment has been tested and found to comply with the limits for a Class A digital device pursuant to Part 15 of FCC Rules. These limits are designed to provide reasonable protection against harmful interference when this equipment is operated in a commercial environment. This equipment generates, uses, and can radiate radio frequency energy and, if not installed and used in accordance with Philips Vari-Lite system, service, and safety guidelines, may cause harmful interference to radio communications. Operation of this equipment in a residential area is likely to cause harmful interference, in which case the user will be required to correct the interference at his/her own expense.

## **CE Declaration of Conformity**

We declare, under our sole responsibility, that this product complies with the relevant clauses of the following standards and harmonized documents:

### **Safety**

EN 60598-1:2015; EN 60598-2-17:1989+A2:1991;EN 62493:2015;EN 62031:2008+A1:2013+A2:2015;EN 62471:2008;Low Voltage Directive 2014/35/EU

### **EMC**

EN 55015:2013  
EN 61000-3-2:2014  
EN 61000-3-3:2013  
EN 61547:2009  
EMC Directive 2014/30/EU  
Same as Legal Entity

### **RoHS**

EN 62321:2012

We certify that the product conforms to the protection requirements of council directives: Low Voltage Directive 2014/35/EU, 2014/30/EU (EMC), and Restriction of the use of certain Hazardous Substances in electrical and electronic equipment Directive (RoHS), 2015/863. Equipment referred to in this declaration of conformity was first manufactured in 2017 in compliance with these standards.

# Safety Notices

It is extremely important to read ALL safety information and instructions provided in this manual and any accompanying documentation before installing and operating the products described herein. Heed all cautions and warnings during installation and use of this product.

Safety symbols used throughout this manual are as follows:



**CAUTION** advising of potential damage to product.



**WARNING** advising of potential injury or death to persons.

GENERAL INFORMATION PERTAINING TO PROTECTION AGAINST ELECTRICAL SHOCK, FIRE, EXPOSURE TO EXCESSIVE UV RADIATION, AND INJURY TO PERSONS CAN BE FOUND BELOW.

## **WARNING:**

### **INSTRUCTIONS FOR CONTINUED PROTECTION AGAINST FIRE**

- 1 Luminaires may be mounted on any type of surface as long as mounting instructions are followed. See instructions detailed in this manual.
- 2 Note distance requirement from combustible materials or illuminated objects for VARI\*LITE luminaires.

## **WARNING:**

### **INSTRUCTIONS FOR CONTINUED PROTECTION AGAINST ELECTRICAL SHOCK**

- 1 VARI\*LITE luminaires are designed for dry locations only. Exposure to rain or moisture may damage luminaire.
- 2 Disconnect power before servicing any VARI\*LITE equipment.
- 3 Servicing to be performed by qualified personnel only.

**WARNING:**

**INSTRUCTIONS FOR CONTINUED PROTECTION AGAINST EXCESSIVE EXPOSURE TO UV RADIATION**

1. Many VARI\*LITE luminaires use a LED that produces UV radiation. DO NOT look directly at LED.
2. It is hazardous to operate luminaires without lens or shield. Shields, lenses, or ultraviolet screens shall be changed if they have become visibly damaged to such an extent that their effectiveness is impaired. For example, by cracks or deep scratches.

**WARNING: INSTRUCTIONS FOR PROTECTION AGAINST INJURY TO PERSONS**

1. Exterior surfaces of the luminaire will be hot during operation. Use appropriate safety equipment (gloves, eye protection, etc.) when handling and adjusting hot equipment and components.
2. Luminaires will have a hot LED when operating. Disconnect power and allow LED to cool before replacing.
3. LED emit ultraviolet radiation which can cause serious skin burn and eye inflammation. Additionally, LED operate under high pressure at very high temperatures. Should the LED break, there can exist a danger of personal injury and/or fire from broken LED particles being discharged.
4. Wear eye protection when relamping.
5. Appropriate safety equipment (gloves, eye protection) should be used when handling damaged LED.
6. If LED is touched with bare hands, clean LED with denatured alcohol and wipe with lint-free cloth before installing or powering up the luminaire.
7. The LED shall be changed if it has become damaged or thermally deformed.

**WARNING: RF INTERFERENCE**

1. This is a Class A product. In a domestic environment this product may cause radio interference, in which case, the user may be required to take adequate measures.

**LED CHARACTERISTIC CONSIDERATIONS**

1. LED require a period of time to relight after a power interruption or a severe voltage dip. In some cases, LED will automatically relight after it has cooled depending on Power-Up State configuration setting.
2. Burning position is Universal.

# Sicherheitshinweise

Es ist äußerst wichtig, ALLE Sicherheitsinformationen und -hinweise in diesem Handbuch und dem beiliegenden Informationsmaterial zu lesen, bevor Sie die hierin beschriebenen Produkte installieren bzw. bedienen. Halten Sie bei der Installation und dem Einsatz dieses Produkts alle Warnhinweise und Vorsichtsmaßnahmen ein.

Folgende Sicherheitssymbole werden in diesem Handbuch verwendet:



**VORSICHT** - weist auf möglichen Produktschaden hin.



hin.

**WARNUNG** - weist auf mögliche Körperverletzung und Lebensbedrohung

NACHSTEHEND FINDEN SIE ALLGEMEINE HINWEISE ÜBER SICHERHEITSVORKEHRUNGEN GEGEN ELEKTROSCHOCK, FEUER, ÜBERHÖHTE UVSTRAHLUNG UND KÖRPERVERLETZUNGEN.

## **WARNUNG: HINWEISE ZUM FEUERSCHUTZ**

1. VARI\***LITE** -Scheinwerfer sind ausschließlich für den Einsatz mit bestimmten Lampentyps. Achten Sie auf den Lampentyp (620 Watt LED), bevor Sie die jeweiligen Lampen ersetzen. Die Installation eines anderen Lampentyps kann gefährlich sein.
2. Scheinwerfer können auf jeder beliebigen Oberfläche montiert werden, solange Sie die Montageanweisungen befolgen. Detaillierte Hinweise finden Sie in diesem Handbuch.
3. Beachten Sie die Einhaltung des erforderlichen Sicherheitsabstandes der VARI\***LITE** -Scheinwerfer von brennbarem Material oder beleuchteten Objekten.

## **WARNUNG: HINWEISE ZUM SCHUTZ GEGEN ELEKTROSCHOCK**

1. VARI\***LITE** -Scheinwerfer eignen sich ausschließlich für trockene Standorte. Regen oder Feuchtigkeit können die Scheinwerfer beschädigen.
2. Unterbrechen Sie die Stromzufuhr, bevor Sie mit der Arbeit an VARI\***LITE** -Geräten beginnen.
3. Die Geräte sollten nur von qualifiziertem Personal gewartet werden.

**WARNING:**

**HINWEISE ZUM SCHUTZ GEGEN ÜBERHÖHTE UV-STRAHLUNG**

1. Viele VARI\*LITE -Scheinwerfer verwenden die Lampentyp, der UV-Strahlen abgibt. SCHAUEN SIE NICHT direkt in die Lampe.
2. Es ist gefährlich, Leuchten ohne Linsen oder Blenden zu bedienen. Blenden, Linsen oder Ultraviolettsschirme müssen ausgetauscht werden, sofern deren Schutzwirkung durch sichtbare Beschädigung (z. B. Sprünge oder Schrammen) eingeschränkt ist.

**WARNING:**

**HINWEISE ZUM SCHUTZ GEGEN KÖRPERVERLETZUNGEN**

1. Bei Betrieb sind die Außenflächen der Scheinwerfer heiß. Verwenden Sie bei der Bedienung von aufgeheizter Apparatur die jeweils geeignete Sicherheitsausrüstung (Handschuhe, Augenschutz etc.).
2. Bei Betrieb der Scheinwerfer ist die Lampe heiß. Unterbrechen Sie die Stromzufuhr und lassen Sie die Lampe abkühlen, wenn Sie diese austauschen.
3. Bogenlampen senden ultraviolette Strahlen aus, die Hautverbrennungen und Augenentzündungen verursachen können. Der Betrieb von Bogenlampen erfolgt unter Hochdruck und bei hohen Temperaturen. Sollte die Lampe zerbrechen, besteht die Gefahr von Körperverletzung bzw. von Feuer, das von Lampenteilen ausgelöst werden kann.
4. Tragen Sie beim Austausch der Lampen einen Augenschutz.
5. Die geeignete Sicherheitsausrüstung (Handschuhe, Augenschutz) sollte beim Umgang mit beschädigten Lampen verwendet werden.
6. Wenn die Lampe mit bloßen Händen berührt wird, reinigen Sie sie mit denaturiertem Alkohol und einem flusenfreien Tuch, bevor Sie die Scheinwerfer installieren oder in Betrieb nehmen.
7. Wenn die Lampe beschädigt oder durch Hitze einwirkung deformiert ist, muß diese ausgetauscht werden.

**WARNING:**

**HF-INTERFERENZ**

1. Es handelt sich um ein Produkt der Klasse A. In einer Wohnumgebung kann das Produkt Hochfrequenzstörungen verursachen. In diesem Fall müssen eventuell geeignete Maßnahmen getroffen werden.

**BESONDERHEITEN VON BOGENLAMPEN**

1. Bogenlampen benötigen eine gewisse Zeitdauer, um nach einem Stromausfall oder einem Spannungsgefälle wieder aufzuleuchten. In einigen Fällen wird die Lampe nach Abkühlung automatisch wieder aufleuchten, je nach der Systemkonfigurationseinstellung des Lampeneinschaltungsstatus.
2. Die Brennposition ist Universal.



# Notes de sécurité

Avant de procéder à l'installation des produits décrits dans ce guide et de les mettre en marche, il est extrêmement important de lire TOUS les renseignements et TOUTES les directives de sécurité contenues dans ce guide ainsi que toute documentation jointe. Tenir compte de tous les avertissements et suivre toutes les précautions pendant l'installation et l'utilisation de cet appareil.

Les symboles de sécurité utilisés dans ce guide sont les suivants :



**ATTENTION** Ce symbole annonce que l'appareil risque d'être endommagé.



**AVERTISSEMENT** Ce symbole annonce qu'il y a risque d'accident grave ou même fatal.

CETTE SECTION CONTIENT DES INFORMATIONS GÉNÉRALES POUR SE PROTÉGER CONTRE LES DÉCHARGES ÉLECTRIQUES , LES INCENDIES, L'EXPOSITION EXCESSIVE AUX RAYONS UV ET TOUT AUTRE ACCIDENT POUVANT ENTRAÎNER DES BLESSURES.

## **AVERTISSEMENT:**

### **DIRECTIVES POUR SE PROTÉGER CONTRE LES INCENDIES**

1. Les luminaires VARI\*LITE ont été conçus pour être utilisés uniquement avec certaines type de lampes. Vérifier le type de lampe (620 Watt LED) avant de remplacer les lampes. L'installation d'un autre type de lampe peut poser un danger.
2. Les luminaires peuvent être fixés sur tout type de surface tant que les directives de montage sont respectées. Voir les explications détaillées dans ce guide.
3. Vérifier la distance à respecter entre les matériaux combustibles ou les objets illuminés et les luminaires VARI\*LITE .

## **AVERTISSEMENT:**

### **DIRECTIVES POUR SE PROTÉGER CONTRE LES DÉCHARGES ÉLECTRIQUES**

1. Les luminaires VARI\*LITE sont conçus pour une utilisation au sec uniquement. Une exposition à la pluie et à l'humidité risque d'endommager le luminaire.
2. Débrancher l'appareil avant de procéder à la révision de tout matériel VARI\*LITE .
3. Les révisions doivent être effectuées uniquement par des personnes qualifiées.

**AVERTISSEMENT:**

**DIRECTIVES POUR SE PROTÉGER CONTRE UNE EXPOSITION EXCESSIVE AUX RAYONS UV**

1. Plusieurs luminaires VARI\*LITE utilisent une lampe qui produit des rayons UV. NE PAS fixer son regard sur la lampe.
2. L'utilisation des luminaires sans lentille ou blindage pose des risques. Tous blindages, lentilles ou écrans ultraviolet visiblement endommagés au point que leur efficacité en est affectée doivent être remplacés, par exemple s'il y a des fissures ou de profondes rayures.

**AVERTISSEMENT:**

**DIRECTIVES POUR SE PROTÉGER CONTRE LES ACCIDENTS POUVANT ENTRAÎNER DES BLESSURES**

1. Les surfaces externes du luminaire deviennent brûlantes quand l'appareil est en marche. Pour manœuvrer ou ajuster des appareils brûlants et leurs composants, se protéger suffisamment (gants, protection pour les yeux, etc.).
2. La lampe du luminaire est brûlante lorsqu'il est en marche. Débrancher le courant et attendre que la lampe ait refroidi avant de la remplacer.
3. Les lampes à arc émettent des rayons ultraviolets pouvant causer de graves brûlures sur la peau et une inflammation des yeux. De plus, les lampes à arc fonctionnent sous haute tension à de très hautes températures. Si la lampe se casse, les particules de la lampe cassée peuvent causer blessures et/ou incendie en s'éparpillant.
4. Se protéger les yeux pour remplacer la lampe.
5. Utiliser des appareils de protection appropriés (gants, protection des yeux) pour manier des lampes endommagées.
6. Si la lampe a été touchée avec des mains nues, la nettoyer avec de l'alcool dénaturé et l'essuyer avec un chiffon non-pelucheux avant d'installer ou de brancher le luminaire.
7. Si la lampe a été endommagée ou a reçu une déformation thermique, elle doit être remplacée.

**AVERTISSEMENT:**

**T:**

**INTERFÉRENCE**

**RF**

1. Cet appareil est de Classe A. Dans un environnement domestique, cet appareil peut causer des interférences radio, et si c'est le cas, l'utilisateur peut avoir à prendre des mesures adéquates.

**CONSIDÉRATIONS DES CARACTÉRISTIQUES DE LAMPES À ARC**

1. Après une interruption de courant ou une baisse importante de voltage, les lampes à arc mettent du temps avant de se rallumer. Dans certains cas, la lampe se rallumera automatiquement après s'être refroidie. Cela dépend de la manière dont le système est réglé pour le statut de mise en marche de la lampe.
2. La position Brûler est Universelle.

# Aviso sobre Seguridad

Es muy importante leer TODA la información e instrucciones sobre seguridad que se indica en este manual así como en los documentos adjuntos antes de instalar y operar los productos descritos. Se debe prestar atención a todos los avisos y advertencias durante la instalación y uso de este producto.

Los símbolos de seguridad usados en este manual son los siguientes:



**CUIDADO**, indica posibles daños al producto.



**ADVERTENCIA**, indica posibles lesiones o muerte a las personas.

LA INFORMACIÓN GENERAL RELACIONADA A LA PROTECCIÓN CONTRAGOLPES DE CORRIENTE ELÉCTRICA, INCENDIO, EXPOSICIÓN EXCESIVA A RADIACIÓN ULTRA VIOLETA Y LESIONES A LAS PERSONAS SE PUEDE ENCONTRAR SEGUIDAMENTE:

## **ADVERTENCIA:**

### **INSTRUCCIONES PARA PROTECCIÓN CONTINUA CONTRA INCENDIO**

1. Las luminarias VARI\*LITE han sido diseñadas para ser usadas solamente con algunas lámparas. Tome nota del tipo de lámpara (620 Watt LED) antes de reemplazarla. Instalación de otro tipo de lámpara puede ser peligroso.
2. Las luminarias se pueden instalar en cualquier tipo de superficie siempre que se sigan las instrucciones de instalación. Vea las instrucciones detalladas en este manual.
3. Tome nota de los requerimientos de distancia de materiales combustibles u objetos iluminados para las luminarias VARI\*LITE .

## **ADVERTENCIA:**

### **INSTRUCCIONES PARA PROTECCIÓN CONTINUA CONTRA CHOQUE ELÉCTRICO**

1. Las luminarias VARI\*LITE están diseñadas solamente para lugares secos. La exposición a la lluvia o humedad pueden dañar la luminaria.
2. Desconecte la energía antes de dar servicio a cualquier equipo de VARI\*LITE .
3. El servicio debe ser realizado solamente por personal calificado.

**ADVERTENCIA:**

**INSTRUCCIONES PARA PROTECCIÓN CONTINUA CONTRA LA EXPOSICIÓN EXCESIVA DE RADIACIÓN ULTRA VIOLETA**

1. Muchas luminarias VARI\*LITE usan un tipo de lámpara que produce radiación UV. NO mire directamente a la lámpara.
2. Es peligroso operar luminarias sin lentes o protectores. Debe cambiar los protectores, lentes o pantallas ultravioletas si se aprecia que han sido dañadas, y que su efectividad pudiera estar deteriorada. Por ejemplo, si tuvieran rajaduras o raspaduras profundas.

**ADVERTENCIA:**

**INSTRUCCIONES PARA PROTECCIÓN CONTRA LESIONES DE PERSONAS**

1. Las superficies exteriores de las luminarias están calientes durante su operación. Use un equipo de seguridad apropiado (guantes, protección para los ojos, etc.) cuando haga ajustes en el equipo y componentes que están calientes.
2. Cuando las luminarias están en operación la lámpara estará muy caliente. Desconecte la energía y deje que la lámpara se enfríe antes de reemplazarla.
3. Las lámparas de arco emiten radiaciones ultravioletas que pueden ocasionar serias quemaduras a la piel e inflamación a los ojos. Además, las lámparas de arco operan a alta presión y muy alta temperatura. Si la lámpara se rompe, puede existir el peligro de lesiones al personal o un incendio ocasionado por las partículas de la lámpara rota que se caen.
4. Use protección para los ojos cuando vuelve a colocar una lámpara nueva.
5. Use un equipo de seguridad apropiado (guantes, protección para los ojos, etc.) cuando trabaje con lámparas dañadas.
6. Si toca la lámpara con las manos, limpie la lámpara con alcohol desnaturalizado y con tela sin pelusas antes de instalar o volver a conectar la luminaria.
7. Cambie la lámpara si está dañada o deformada termicamente.

**ADVERTENCIA:**

**INTERFERENCIA**

**RF**

1. Este es un producto de Clase A. En el ambiente de la casa este producto puede ocasionar radiointerferencia, en cuyo caso, el usuario debe tomar las medidas adecuadas.

**CONSIDERACIONES SOBRE LAS CARACTERÍSTICAS DE LA LÁMPARA DE ARCO**

1. Las lámparas de arco requieren un período de tiempo para volver a iluminarse después de una interrupción de energía o de una severa caída de voltaje. En algunos casos, la lámpara se volverá a iluminar en forma automática después que se ha enfriado dependiendo de la configuración del sistema de energía de la lámpara.
2. La posición de encendido es universal.

**Introduction**

About This Manual..... 1  
 Additional Documentation..... 1  
 Text Conventions ..... 2  
 Customer Service ..... 2

**Chapter 1. Description**

Features

VLZ PROFILE Standard Features ..... 4

Components

Included Items ..... 5  
 Items/Accessories ..... 6  
 Overview..... 7

**Chapter 2. Installation**

Special Warnings

Exceptional Safety Information for the VLZ PROFILE Luminaire ..... 10

Power and Data Cabling Requirement

Power..... 11  
 DMX Termination Connector ..... 13

Installation Procedures

Hanging the Luminaire ..... 14  
 Floor Mounting the Luminaire ..... 16

Powering Up

Power Up and Configuration Procedure ..... 17

Addressing

Program Starting Address ..... 18  
 Program Starting Address Without Calibrating Luminaire ..... 18

**Chapter 3. Operation**

VLZ PROFILE DMX Channels

VLZ PROFILE Channel Mapping..... 20  
 VLZ PROFILE Control Channel Functions ..... 27

VLZ PROFILE DMX Mapping

VLZ PROFILE Color Control ..... 29  
 Color Mixing ..... 29  
 Fixed Color Wheel..... 29  
 Fixed Color Wheels DMX Map ..... 30  
 VLZ PROFILE Beam Control ..... 30  
 Strobe..... 30  
 VLZ PROFILE Gobo/Effects Control..... 31  
 Overview of Gobos used in VLZ PROFILE Luminaire..... 31  
 Gobo Use and Positioning..... 31  
 Gobo Wheels 1 and 2 ..... 32  
 Index and Rotation ..... 34

VARI\*LITE VLZ PROFILE Luminaire User’s Manual

VLZ PROFILE Luminaire Timing  
VLZ PROFILE Timing Channel Information..... 36

Updating Software  
Software From Luminaire to Luminaire ..... 38

**Chapter 4. Menu System**

Menu Operation  
What Is the Menu System? ..... 42  
Controls Operation ..... 42  
Default State..... 43

Menu Functions  
VLZ PROFILE Menu System Function Chart..... 44  
Menu Function Definitions ..... 47

Self-Tests  
Running Parameter Tests..... 48

**Appendix A. Luminaire Care and Routine Maintenance**

Equipment Handling  
Locations/Use ..... 51  
LED ..... 51  
Servicing ..... 51  
Heat..... 51  
LED Features/Benefits ..... 51  
Solid State Electronics ..... 52  
Electrostatic Discharge (ESD) ..... 52  
Printed Circuit Boards (PCBs)..... 52

Troubleshooting  
Error Messages ..... 53  
Troubleshooting Guide..... 54

Routine Maintenance  
LED Replacement ..... 55  
Gobo Replacement - Gobo Wheels ..... 56  
Cleaning Optics, Filters and Gobos..... 59  
Followspot Handle Accessory Installation (Optional) ..... 60

**Appendix B. Technical Specifications**  
VLZ PROFILE Luminaire..... 63

# Introduction

---

## About This Manual

This manual provides necessary information regarding safety, installation, operation and routine maintenance for Philips VARI\*LITE VLZ PROFILE Luminaires. Familiarizing yourself with this information will help you to get the most out of your luminaire.



---

---

**WARNING:** It is important to read ALL accompanying safety and installation instructions to avoid damage to the product and potential injury to yourself or others.

---

---

This manual covers the following models:

Model	Part Number	Source
VLZ PROFILE Luminaire	26-105-0002-00	620Watt Atria TM SUL620-80-R70-000 LED

---

## Additional Documentation

A service manual, only for Authorized Philips VARI\*LITE Service Centers and technicians, of the VLZ PROFILE Luminaire is available in electronic (PDF) format:

- Luminaire Service Manual
- Testing, Troubleshooting, Component Replacement and Illustrated Parts Breakdown.

---

**Note:** Performing maintenance procedures may void the product warranty. Refer to the Philips Vari-Lite Limited Warranty card included in the product shipping package for more information.













---

For more information on installing DMX512 control systems, the following publication is available for purchase from the United States Institute for Theatre Technology (USITT), "Recommended Practice for DMX512: A Guide for Users and Installers, 2nd edition" (ISBN: 9780955703522). USITT Contact Information:

USITT Inc.  
 315 South Crouse Avenue Suite 200  
 Syracuse, NY 13210  
 Tel: 800-938-7488 or +1-315-463-6463  
 Fax: 866-398-7488 or +1-315-463-6525  
[www.usitt.org](http://www.usitt.org)

## Text Conventions

The following styles and meanings are used throughout this manual:

Style	Meaning
[Button]	Front panel button. Example: Press [MODE/ESC]/ 
   	Press either     arrow button at Menu Display.
MENU	LCD Menu Display read-out. Example: Press     arrows until DMX appears.

## Customer Service

### Our Goal

At Philips Vari-Lite, we are committed to providing you the highest quality in customer service. Our comprehensive resources are available to help your business succeed and ensure you get the full benefit of being a Philips Vari-Lite customer. Whether your needs are telephone troubleshooting assistance, product training or technical service, our full-time staff of experienced professionals is on-hand to provide support.

### How to Reach Us

For assistance in your area, call the dealer from which your product was purchased.

or

Contact an Authorized VARI\*LITE Service Center.

or

Contact the Philips Vari-Lite Customer Service Department, 9am -6pm CST Monday through Friday, at the following:

phone: 1-877-VARI-LITE (1-877-827-4548) or +1-214-647-7880

email: [entertainment.service@philips.com](mailto:entertainment.service@philips.com)

### Additional Resources

For additional resources and documentation, please visit our website at

<http://www.philips.com/entertainmentlighting> and follow the Support link.



# CHAPTER 1.

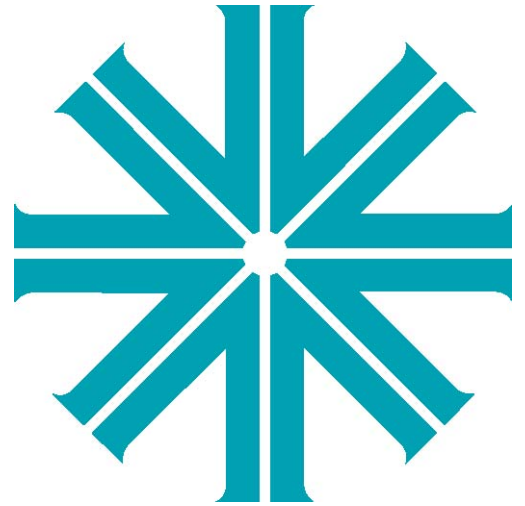

## **Description**

This chapter contains descriptions of luminaire features and components, along with a list of accessories which are available.

- **Features**
- **Components**

# Features



---

## VLZ PROFILE Standard Features

The VLZ PROFILE Luminaire has the following standard features:

- Zoom optics system with 6.3° to 55° range.
- CMY color mixing system.
- One fixed color wheels.
- Variable CTO color temperature correction wheel.
- Mechanical iris provides continuous beam size control.
- Two gobo/effects wheels combine to each offer rotatable, indexable gobo positions and one open position.
- Independent, drop-in armature that rotates with prism.
- Independent, drop-in armature that contains variable frost.
- Full-field dimming system.
- Dual blade strobe system.
- Repositionable pan/tilt system.
- Control by DMX512 protocol.
- Fan cooled.
- 620Watt Atria TM SUL620-80-R70-000 LED.



---

**Note:** For more information and product specifications, refer to “Technical Specifications” on page 64.

---

# SPOT Features

## Included Items

The following illustration shows all items included with the luminaire:

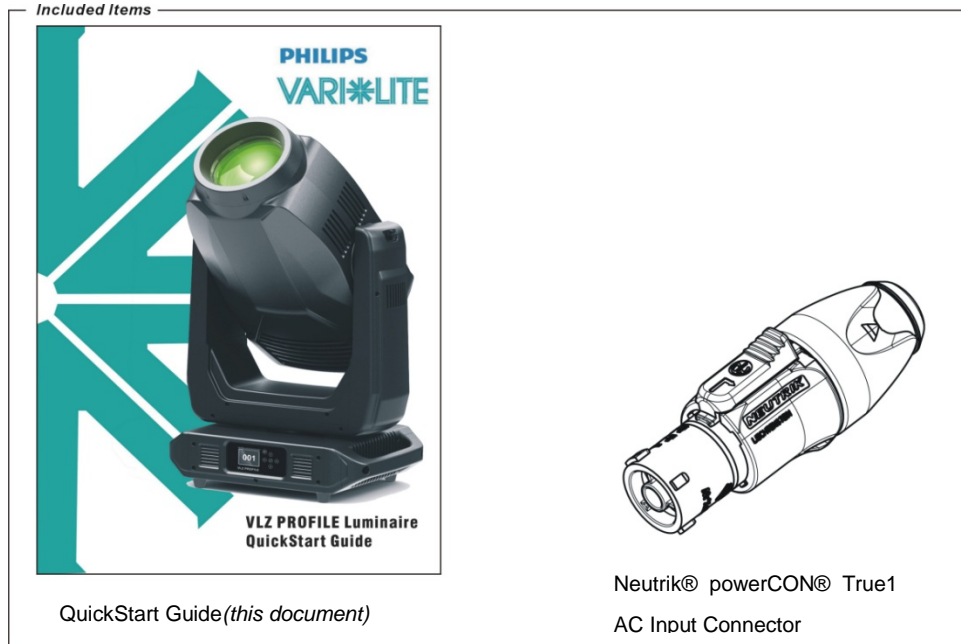

**Figure 1-1: VLZ PROFILE Luminaire Included Items**

Note: \* Please Check with the local Philips Entertainment Office or Authorized Vari\*Lite dealer for availability on accessories.

### **Replacement Items/Accessories**

The following optional and/or replacement items can be ordered directly from your Authorized Philips Vari-Lite Dealer. (Please order by Philips Vari-Lite part number.)

<b>Philips Number</b>	<b>Vari-Lite Part</b>	<b>Accessory Description</b>



## Luminaire Overview

The following illustration shows the external luminaire components and controls.

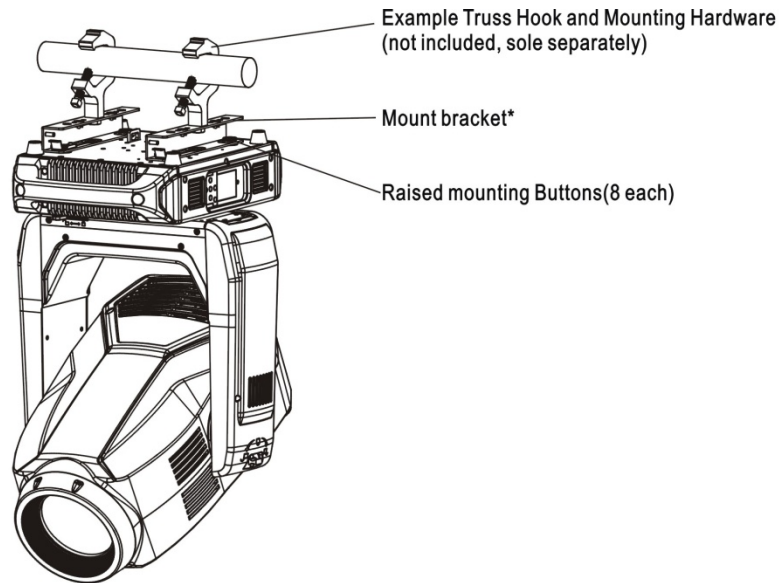

Fit bracket's keyed hole and locking mechanism over raised mounting buttons and slide forward.

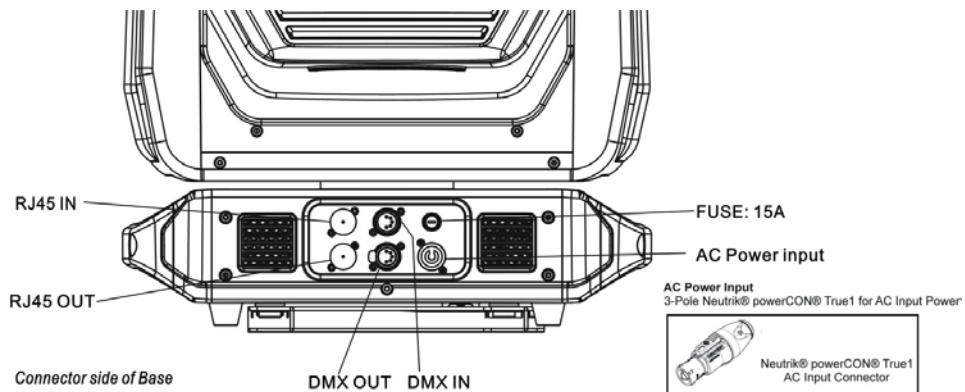
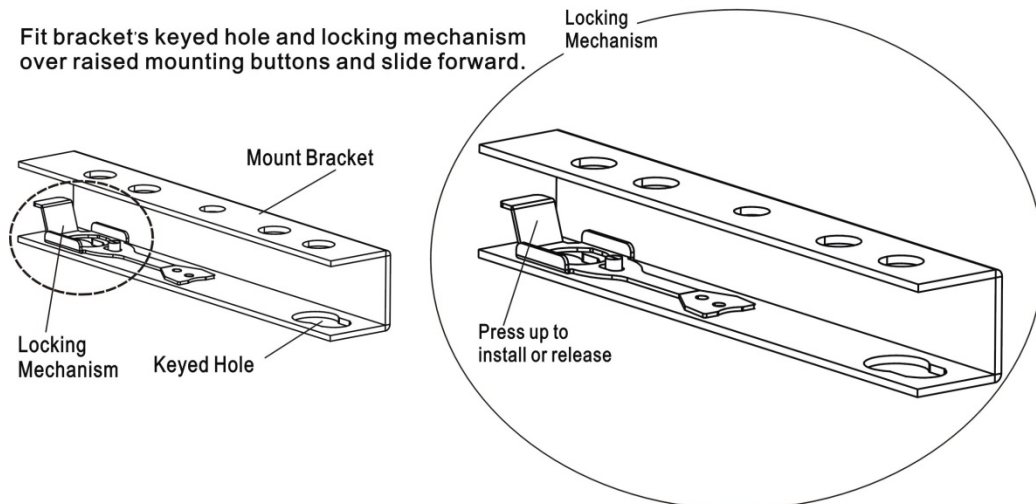

Notes

## CHAPTER 2.

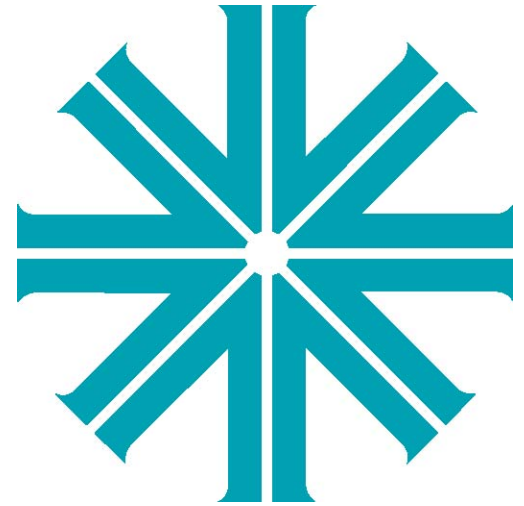

### **Installation**

This chapter contains instructions for installation of the luminaire. It includes connecting power and data, along with instructions for powering up the luminaire for the first time and addressing it within your system.

- **Special Warnings**
- **Power and Data Cabling Requirements**
- **Installation Procedures**
- **Powering Up**
- **Addressing**



## Special Warnings

---

### Exceptional Safety Information for the VLZ PROFILE Luminaire

The light intensity and power density of the VLZ PROFILE Luminaire exceeds that of other fixtures typically used in this application. The warnings and cautions that follow are critically important to the safe operation of this fixture. This product is for commercial use only by trained professionals only.

If you have any questions about the safe installation and operation of the VLZ PROFILE Luminaire, please contact Vari-Lite customer service at 1-877-VARI-LITE (1-877-827-4548), +1-214-647-7880, or [entertainment.service@philips.com](mailto:entertainment.service@philips.com).



---

**WARNING: Light Beam Projects Intense Heat.** Do not illuminate objects within 2.0 m (6.6 feet) of the VLZ PROFILE Luminaire. Objects within this range can scorch, melt, or ignite from the heat projected by the light beam.

---



---

**WARNING: High Intensity Light Output.** Do not look directly into the light beam. Avoid looking at nearby surfaces illuminated by the beam. It is hazardous to operate luminaires without lens or shield. Shields, lenses, or ultraviolet screens must be changed if they have become visibly damaged to such an extent that their effectiveness is impaired. For example, by cracks, deep scratches, or coating breakdown.

---



---

**WARNING: Hot Exterior Surfaces.** The exterior surfaces of the luminaire can get very hot - up to 85°C (185°F). Do not touch any surface of the luminaire while it is operating. Keep all combustible materials a minimum of 200 mm (8 inches) away from the luminaire. To maintain cooling fan operation after the LED is doused, keep the luminaire powered on for 5 minutes. Wait an additional 5 minutes before touching the luminaire.

---



---

**WARNING: Operating Environment.** Do not operate the luminaire when the ambient temperature exceeds 45°C (113°F).

---



---

**WARNING: Approved LED Type.** Use only approved LED types in VLZ PROFILE Luminaire. Users can check the latest version of Vari-Lite Technical Notice TN-248, on the Vari-Lite web site, for all approved LED.

---

# Power and Data Cabling Requirements

## Power

The luminaire requires standard AC power distribution from AC100-240V~, 50/60Hz. Current required depends on the AC supply voltage and product model.



**Note:** The mating Neutrik PowerCon connector is supplied, however, you will need to purchase or construct a cable appropriate for your application.

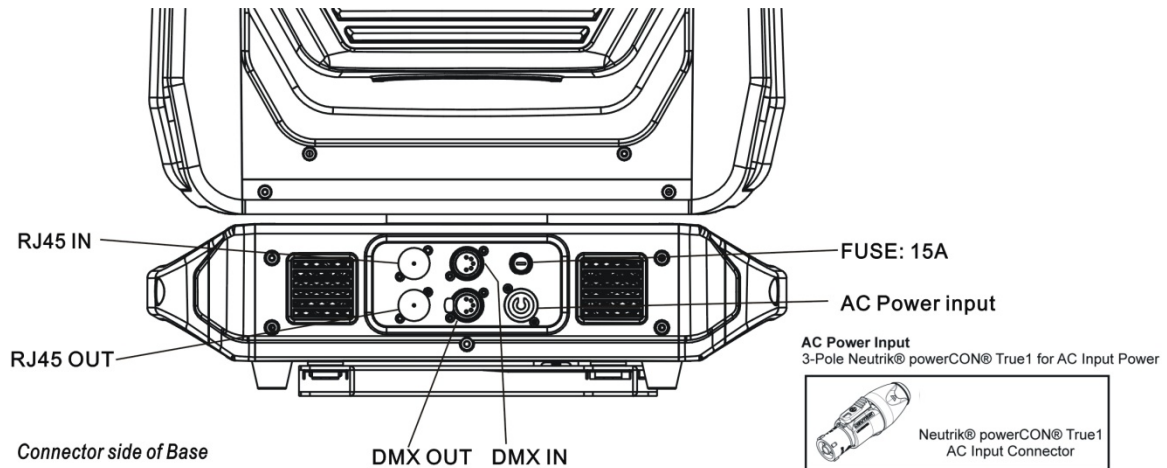

Figure 2-1: Power Connector

Depending on the application, the luminaire's AC input cable may require a different connector. If required, install a new connector meeting your requirements using the following wire color code reference:

Wire*	Connection
Green	AC Ground
White	AC Neutral
Black	AC Line
* International (Harmonized) Standard	



**WARNING:** DO NOT connect to three-phase service in countries with 240 volt power.

**AVERTISSEMENT:** NE PAS se connecter au service en trois phases dans les pays avec puissance de 240 volts.

For single-phase power at 240 volts RMS:

Connection	Pin
AC Neutral	X
AC Line	Y
Ground(Earth)	G



For three-phase power at 208 volts RMS:

Connection	Pin
Phase 1	X
Phase 2	Y
Ground (Earth)	G



---



---

**WARNING:** It is not recommended to power any VARI\*LITE luminaire from a dimmer - even in 'NONDIM' mode. Dimmer and non-dim modules are not suitable sources of power because their output modifies the AC wave form. This may work for a short time, but will eventually result in power problems, luminaire mis-operation and/or failure and may void the luminaire's warranty.

---



---

## **DMX Termination Connector**

A DMX termination connector is required at the last luminaire (or "far end of the line") to prevent signal reflections. Signal reflections may cancel out the signal at certain line lengths, resulting in errors. The terminator is also necessary for software downloads and running tests on multiple luminaires. To construct your own connector, you will need the following components:

- 5-pin, male XLR connector.
- Two 1/4W 5% 120 ohm resistors.

---

**Note:** A DMX termination connector assembly is available as an accessory from Philips Vari-Lite. See "Replacement Items/Accessories" on page 6.

---

# Installation Procedures

---

## Hanging the Luminaire

The VLZ PROFILE Luminaire can be hung horizontally or vertically from any structure designed to work with the type of load created by this moving luminaire. Two mounting truss hooks or other mounting hardware are required. Many compatible truss hooks are available from different manufacturers for your particular needs. A minimum of two hooks per luminaire is required. If mounting method does not use truss hooks, two attachment points, per luminaire, are required.

### Install mounting hardware and brackets:

Step 1. Install truss hooks on two provided truss hook brackets as required as shown in **Figure 2-2**.

Step 2. Determine required configuration of bracket installation. Brackets may be installed in many different orientations as shown in **Figure 2-3**.

Step 3. While pulling up on locking mechanism release, fit keyed holes onto raised mounting buttons at bottom of enclosure. Slide forward and release locking mechanism to lock in place. Ensure brackets are locked securely.

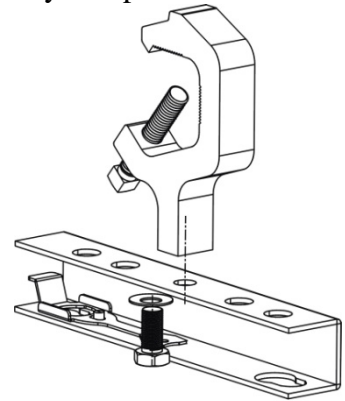

**Figure2-2:Truss Hook Installation**



---

**WARNING:** Ensure that the bracket locking mechanism is fully seated after the bracket is installed on the luminaire.

**AVERTISSEMENT:** Assurez-vous que le mécanisme de support de verrouillage est complètement inséré après le support est installé sur l'appareil.

---

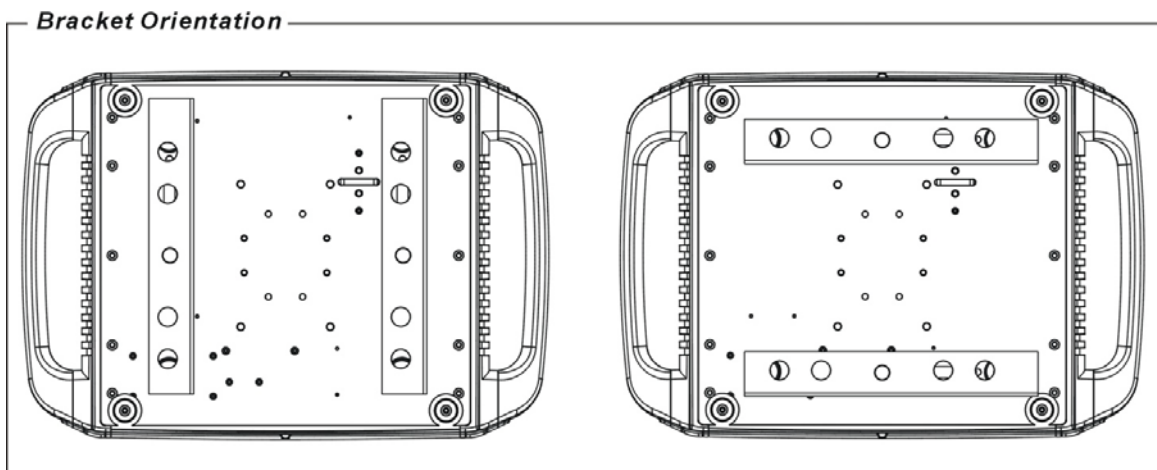
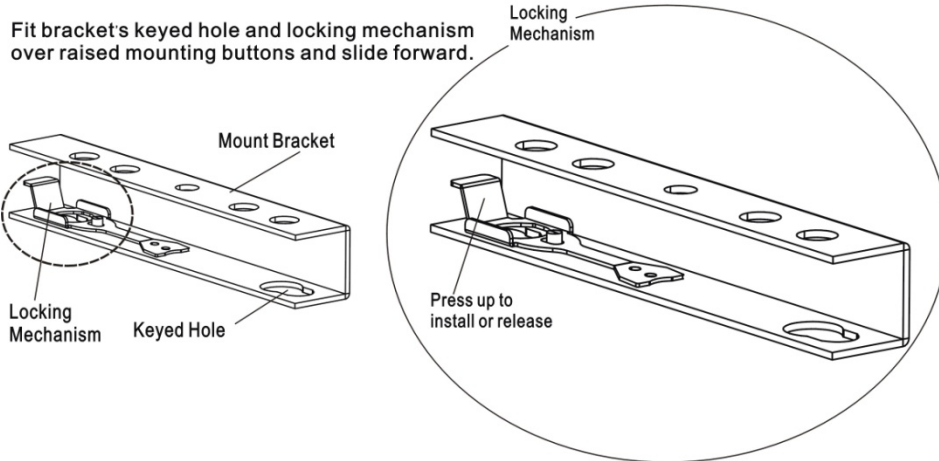
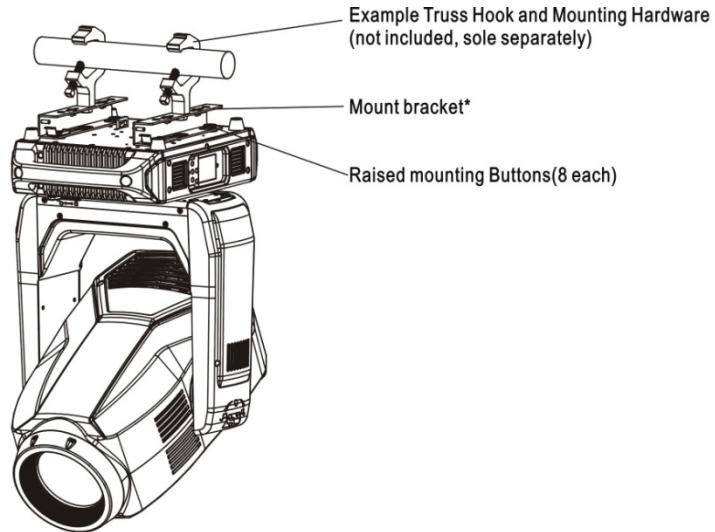

Figure 2-3: Installing Brackets on Luminaire Enclosure

---

## Floor Mounting the Luminaire

All luminaires included in this manual are designed to sit directly on its base in a floor installation application. When used in this type of application, be sure to leave enough space around the luminaire to allow proper, uninterrupted airflow for cooling and movement.



---

**WARNING: Light Beam Projects Intense Heat.** Do not illuminate objects within 2.0 m (6.6 feet) of the VLZ PROFILE Luminaire. Objects within this range can scorch, melt, or ignite from the heat projected by the light beam.

---



---

## Connecting Data and Power

A maximum of 32 luminaires may be connected in any one DMX data link.

---

**Note:** This maximum limit applies to the luminaire "daisy chain" only. Your system or console may require fewer luminaires on a single data link path. Consult your console documentation for more information.

---

### To connect power and data:

- Step 1. Connect data cable from console to first luminaire in chain at DATA IN connector.
- Step 2. If required, connect additional data cables from DATA THRU connectors to DATA IN connectors of remaining luminaires in link.
- Step 3. At last luminaire in link, install male termination connector at DATA THRU connector. (Luminaires and other devices on the same DMX chain may not function properly without termination.)

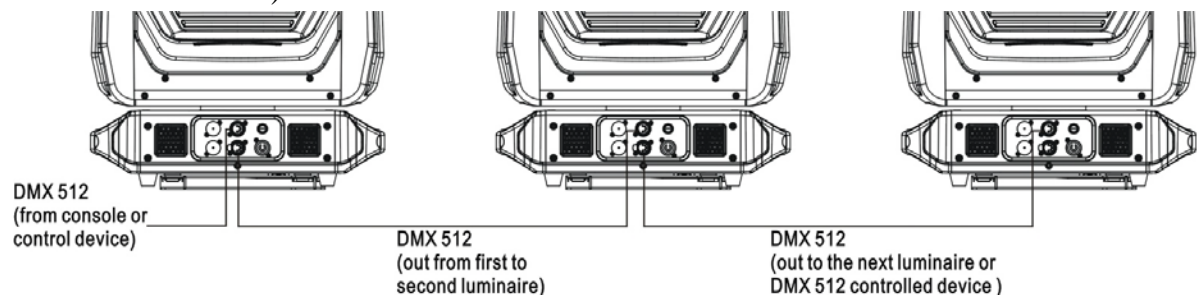

Figure 2-4: Data Link

- Step 4. Connect AC Input Cable connector to power input source.
- Step 5. Dress AC input and data cables and secure them so that they will not interfere with luminaire head and yoke movement.

# Powering Up

---

## Power Up and Configuration Procedure

The internal color, gobo, and beam mechanisms will also move through a full range of motion. After calibration, the luminaire head will either stop at its "home" position (which positions the pan axis at mid-rotation and the head parallel to the yoke with the lens pointing away from the luminaire upper enclosure) or move to its current DMX-defined position if DMX data is present. All internal mechanisms also move to their "home" or DMX-defined positions.

Subsequently, depending on the luminaire's setting for Power-Up State (refer to [“VLZ PROFILE Menu System Function Chart”](#) on page 45).



**CAUTION:** Before applying power, be sure the luminaire is hung or positioned so that the head and yoke can move freely without restriction. Make sure service tilt and pan locks are disengaged so luminaire moves freely.

---

### To power up:

At each luminaire, apply power by connecting luminaire to input power source (100 to 240VAC). Luminaire will automatically step through following procedure:

- a. Luminaire will cycle through calibration and stop at "home" position.



# Addressing

---

## Program Starting Address

The address setting for DMX console controlled systems is entered using the Menu Display (refer to “[Menu Operation](#)” on page 43). The luminaire retains the DMX address even if power is removed.

---

**Note:** Refer to your console operating instructions for specific information regarding its addressing requirements.

---

### Program a DMX starting address:

Step 1. Make sure unit is powered and turned on.

Step 2. Press [MODE/ESC] to access menu categories.

Step 3. Use four Arrow (⬆️ ⬇️ ⬅️ ➡️) buttons to navigate through the various options and settings.

Step 4. Once menu item is reached, press OK (⏹️) to access the menu item parameters.

Step 5. Make changes to parameters as desired.

Step 6. Press (⏹️) button to accept changes.

---

## Program Starting Address Without Calibrating Luminaire

It is possible to bypass the calibration sequence and go directly to the Menu Display programming in order to pre-program an address setting.

Program starting address without calibrating luminaire:

- While powering up luminaire, press and hold [MODE/ESC]. Program address as in Program Starting Address above.
  - Press and hold [MODE/ESC] until display changes to the DMX address.
- 

**Note:** The luminaire will require a reset to restore control. See “[VLZ PROFILE Control Channel Functions](#)” [chapter on page 27](#) for control channel information on luminaire reset.

---

## CHAPTER 3.

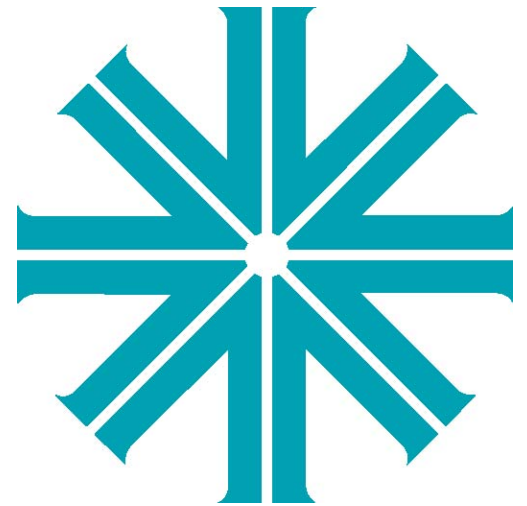

### **Operation**

This chapter contains instructions for operating the luminaire using DMX control and for updating the internal software.

**[VLZ PROFILE DMX Channels](#)**

**[VLZ PROFILE DMX Mapping](#)**

**[VLZ PROFILE Luminaire Timing](#)**

**[Updating Software](#)**

# VLZ PROFILE DMX Channels

## VLZ PROFILE Channel Mapping

These tables assume a DMX start address of 1. When a different starting address is used, this address becomes channel 1 function and other functions follow in sequence.

**Table 3-1: VLZ PROFILE DMX Channel Mapping**

**DMX channel's functions and their values (61 DMX channels):**

DMX Channel	Parameter	Range DMX	Defaults	Description
1 2	<b>Intensity</b> High Byte Low Byte	0-65535	0	16-bit control of Fixture Intensity from 0 - 100%
3 4	<b>Pan</b> High Byte Low Byte	0 - 65535	32767	16-bit linear control of pan from 0°-540°. With Expanded Movement turned on, 630° of pan is possible
5 6	<b>Tilt</b> High Byte Low Byte	0 - 65535	32767	16-bit linear control of tilt from 0°-270°.
7 8	<b>Edge</b> High Byte Low Byte	0 - 65535	32767	16-bit linear control of edge functions
9 10	<b>Zoom</b> High Byte Low Byte	0 - 65535	32767	16-bit linear control of fixture zoom range between 0 (narrow) to 65535 (wide).
11	<b>Programming Control</b>	0 - 255  0 - 2 3 - 5 6 - 10 11 - 15 16 - 20 51 - 55 56 - 60	0  → → → → → → →	Used as a control channel for different programmable settings. Set value of desired effect, wait >3 seconds, then set a descreet value to 0 (Idle).  Idle Linear Dimming Curve Square Law Dimming Curve TV Dimming Curve Architectural Dimming Curve Edge Track ON Edge Track OFF
12	<b>Cyan</b> High Byte	0 - 65535	0	16 Bit control of cyan color mechanism.

13	Low Byte			
14 15	<b>Yellow</b> High Byte Low Byte	0 - 65535	0	16 Bit control of yellow color mechanism.
16 17	<b>Magenta</b> High Byte Low Byte	0 - 65535	0	16 Bit control of Magenta color mechanism.
18 19	<b>CTO</b> High Byte Low Byte	0 - 65535	0	16 Bit control of CTO mechanism.
20	<b>Color Wheel 1</b>	0 - 255  0 - 17 18 - 43 44 - 83 84 - 118 119 - 155 156 - 192 193 - 225 226 - 255	0  → → → → → → → →	8-bit linear control of Color Wheel 1. See Channel 16 for options.  OPEN COLOR 1 - RED (Center at DMX 35) COLOR 2 - YELLOW (Center at DMX 71) COLOR 3 - KELLY GREEN (Center at DMX 107) COLOR 4 - MAGENTA (Center at DMX 143) COLOR 5 - AMBER (Center at DMX 179) COLOR 6 - CONGO BLUE (Center at DMX 215) OPEN END - NO COLOR

DMX Channel	Parameter	Range DMX	Defaults	Description
-------------	-----------	-----------	----------	-------------

21	<b>Color Wheel 1 Control</b>	0 - 255  0 - 5 6 - 10 11 - 15 16 - 20 21 - 25 26 - 56 57 - 87 88 - 255	0  → → → → → → → →	Used as a control channel for different movement options of Color Wheel 1.  Linear Movement using shortest (quickest) path. Linear Movement using normal (longest) path. Wheel Spin >>>>> (Slow to Fast) Wheel Spin STOP Wheel Spin <<<<< (Slow to Fast) Color Shake Quickest Path (Slow to Fast) Color Shake Normal Path (Slow to Fast) Reserved Values
22	<b>Gobo Wheel 1</b> (Fixed Gobo Wheel)	0 - 255  0 - 27 28 - 55 56 - 83 84 - 111 112- 139 140 - 167 168 - 195 196 - 223 224 - 255	0  → → → → → → → → →	8-bit control of Gobo Wheel 1. See Channel 23 for control options.  Open - No Gobo (白圆) Gobo 1 - LEAFY BREAKUP Gobo 2 - MEDIUM CIRCLE Gobo 3 - LATTICE Gobo 4 - SWIRL Gobo 5 - RADIAL BREAKUP Gobo 6 - NEURONS Gobo 7 - GRID Open End - No Gobo

23	<b>Gobo Wheel 1 Control</b>	0 - 255	0	Used as a control channel for different movement options for Gobo Wheel 1
		0 - 5	→	Linear Movement using shortest (quickest) path.
		6 - 10	→	Linear Movement using normal (longest) path.
		11 - 15	→	Wheel Spin >>>>>> (Fast to Slow )
		16 - 20	→	Wheel Spin STOP
		21 - 25	→	Wheel Spin <<<<<< (Slow to Fast)
		26 - 56	→	Gobo Shake Quickest Path (Slow to Fast)
		57 - 87	→	Gobo Shake Normal Path (Slow to Fast)
		88 - 255	→	Reserved Values
24	<b>Gobo Wheel 2 (Rotating Gobo Wheel)</b>	0 - 255	0	8-bit control of Gobo Wheel 2. See Channel 27 for control options.
		0 - 5	→	Open - No Gobo
		6 - 10	→	Gobo 1 (Night Sky) Index
		11 - 15	→	Gobo 2 (Circle of Ovals) Index
		16 - 20	→	Gobo 3 (Bricked Out) Index
		21 - 25	→	Gobo 4 (Punch Card) Index
		26 - 30	→	Gobo 5 (Alpha Rays) Index
		31 - 35	→	Gobo 6 (HONEYCOMB) Index
		36 - 40	→	Gobo 7 (On the Rocks) Index
		41 - 45	→	Open - No Gobo
		46 - 50	→	Gobo 1 (Night Sky) Rotate
		51 - 55	→	Gobo 2 (Circle of Ovals) Rotate
		56 - 60	→	Gobo 3 (Bricked Out) Rotate
		61 - 65	→	Gobo 4 (Punch Card) Rotate
		66 - 70	→	Gobo 5 (Alpha Rays) Rotate
		71 - 75	→	Gobo 6 (HONEYCOMB) Rotate
		76 - 80	→	Gobo 7 (On the Rocks) Rotate
				Gobo Wheel 2 Continued on Next Page

DMX Channel	Parameter	Range DMX	Defaults	Description
-------------	-----------	-----------	----------	-------------

24	<b>Gobo Wheel 2</b> Continued from Previous Page	81 - 85	→	Open - No Gobo
		86 - 90	→	Gobo 1 (Night Sky) Rotate with Mega Stepping
		91 - 95	→	Gobo 2 (Circle of Ovals) Rotate with Mega Stepping
		96 - 100	→	Gobo 3 (Bricked Out) Rotate with Mega Stepping
		101 - 105	→	Gobo 4 (Punch Card) Rotate with Mega Stepping
		106 - 110	→	Gobo 5 (Alpha Rays) Rotate with Mega Stepping
		111 - 115	→	Gobo 6 (HONEYCOMB) Rotate with Mega Stepping
		116 - 120	→	Gobo 7 (On the Rocks) Rotate with Mega Stepping
		121 - 255	→	Reserved Values
25 26	<b>Gobo 2 Rot/Index</b> High Byte Low Byte	0 - 65535	32767	16-bit control of index and rotation of gobo wheel 1.

		0~126 127~128 129- 255	→ → →	Rotate Fast to Slow <<<<<<<< Rotation STOP Rotate Slow to Fast >>>>>>>
27	<b>Gobo Wheel 2 Control</b>	0 - 255  0 - 5 6 - 10 11 - 20 21 - 50 51 - 60 61 - 90 91 - 120 121 - 150 151 - 180 181 - 210 211 - 255	0  → → → → → → → → → → → →	Used as a control channel for different movement options for Gobo Wheel 1 (Channel 24).  Gobo Selection using shortest (quickest) path.  Gobo Selection using normal (longest) path. Reserved Values Wheel Spin >>>>>>> ( Fast to Slow ) Wheel Spin STOP Wheel Spin <<<<<<< (Slow to Fast) Gobo Shake Quickest Path (Slow to Fast) Gobo Shake Normal Path (Slow to Fast) Gobo Twist Quickest Path (Slow to Fast) Gobo Twist Normal Path (Slow to Fast) Reserved Values
28	<b>Animation 1</b>	0 - 255  0 - 126 127 - 255	0  → →	Inserts animation wheel into beam.  Animation Wheel OUT Animation Wheel IN
29 30	<b>Animation 1</b> Rot/Index  High Byte Low Byte	0 - 255  0 - 126 127 - 128 129 - 255	0  → → →	16-bit control of index and rotation of Animation Wheel 1.  Rotate Fast to Slow >>>>>>> Rotation STOP Rotate Slow to Fast <<<<<<<
31	<b>Animation 1 Control</b>	0 - 255  0 - 5 6 - 10 11 - 15 16 - 20 21 - 25 26 - 56  57 - 87  88 - 255	0  → → → → → →  →  →	Used as a control channel for Animation Wheel 1. Index using shortest (quickest) path. Index using normal (longest) path.  Rotate Normal Rotate with Mega Stepping Reserved Values Image Shake using shortest (quickest) path slow to fast. Image Shake using normal (longest) path slow to fast. Reserved Values
32	<b>Iris</b>	0 - 255	0	Controls Iris mechanism from open (DMX 0) to Full (DMX 255).

DMX Channel	Parameter	Range DMX	Defaults	Description
-------------	-----------	-----------	----------	-------------

33 34	<b>Frame 1A</b> High Byte Low Byte	0 - 65535	0	16 Bit Control of Framing Shutter 1A from Open (DMX 0) to Full (DMX 65535).
----------	--	-----------	---	---

35 36	<b>Frame 1B</b> High Byte Low Byte	0 - 65535	0	Controls Framing Shutter 1B from Open (DMX 0) to Full (DMX 255).
37 38	<b>Frame 2A</b> High Byte Low Byte	0 - 65535	0	Controls Framing Shutter 2A from Open (DMX 0) to Full (DMX 255).
39 40	<b>Frame 2B</b> High Byte Low Byte	0 - 65535	0	Controls Framing Shutter 2B from Open (DMX 0) to Full (DMX 255).
41 42	<b>Frame 3A</b> High Byte Low Byte	0 - 65535	0	Controls Framing Shutter 3A from Open (DMX 0) to Full (DMX 255).
43 44	<b>Frame 3B</b> High Byte Low Byte	0 - 65535	0	Controls Framing Shutter 3B from Open (DMX 0) to Full (DMX 255).
45 46	<b>Frame 4A</b> High Byte Low Byte	0 - 65535	0	Controls Framing Shutter 4A from Open (DMX 0) to Full (DMX 255).
47 48	<b>Frame 4B</b> High Byte Low Byte	0 - 65535	0	Controls Framing Shutter 4A from Open (DMX 0) to Full (DMX 255).
49 50	<b>Frame Rotate</b> High Byte Low Byte	0 - 65535	32767	Controls Framing Shutter mechanism from +/- 90°
51	<b>Prism</b>	0 - 255  0 - 5 6 - 10  11 - 15 16 - 20 21 - 255	0  → →  → → →	Controls Prism mechanism with following values.  Open Index  Rotate Normal Rotate with Mega Stepping Reserved Values
52 53	<b>Prism Index/Rot</b> High Byte Low Byte	0 - 65535  0 - 126 127 - 128  129 - 255	32767  → →  →	16-bit control of prism rotation and index.  Rotate Fast to Slow >>>>>> Rotation STOP  Rotate Slow to Fast <<<<<<
54	<b>Frost</b>	0 - 255  0 - 50 51 - 100 101 - 150 151 - 200	0  → → → →	Insert control of frost mechanism with the following values. Open - No Frost or Diffusion Insert Light Diffusion Insert Heavy Frost Insert both Light Diffusion and Heavy Frost

OPERATION: VLZ PROFILE DMX MAPPING

3

DMX Channel	Parameter	Range DMX	Defaults	Description
55	<b>Strobe</b>	0 - 255	0	Controls Strobe functionality.
		0 - 3	→	Open
		4 - 6	→	Closed
		7 - 32	→	Normal Strobe - Slow to Fast
		33 - 58	→	Random Strobe - Slow to Fast
		59 - 84	→	Random Sync - Slow to Fast
		85 - 110	→	Pulse > - Slow to Fast
		111 - 136	→	Pulse > Random - Slow to Fast
		137 - 162	→	Pulse > Random Sync - Slow to Fast
		163 - 188	→	Pulse < - Slow to Fast
		189 - 214	→	Pulse < Random - Slow to Fast
		215 - 240	→	Pulse < Random Sync - Slow to Fast
		56	<b>Focus Timing</b>	0 - 255
57	<b>Optics Timing</b>	0 - 255	255	Adjustment of fixture timing to control lensing mechanisms. - See Timing Channel Chart in User Manual
58	<b>Color Timing</b>	0 - 255	255	Adjustment of fixture timing to control color mechanisms. - See Timing Channel Chart in User Manual
59	<b>Beam Timing</b>	0 - 255	255	Adjustment of fixture timing to control beam shaping mechanisms. - See Timing Channel Chart in User Manual
60	<b>Gobo Timing</b>	0 - 255	255	Adjustment of fixture timing to control gobo mechanisms. - See Timing Channel Chart in User Manual
61	<b>Luminaire Control</b>	0 - 255	0	Control Channel used for full fixture settings, lamp controls, and miscellaneous modes. Set descreet value of desired effect, wait >3 seconds, then set value to 0 (Idle).
		0 - 5	→	Idle (Default)
		6 - 10	→	Full Luminaire ReCal - Also Used to Wake fixture up from shutdown
		11 - 15	→	Reserved Values
		16 - 20	→	Reserved Values
		21 - 25	→	Fixture Shutdown
		26 - 30	→	Display - Menu ON
		31 - 35	→	Display - Menu OFF
		36 - 40	→	ReCal Position
		41 - 45	→	ReCal Color
		46 - 50	→	ReCal Gobo
		51 - 55	→	ReCal Beam
		56 - 60	→	ReCal Optics
61 - 65	→	Reserved Values		



		66 – 70	→	Reset Fixture to Defaults - See Manual for a list of factory defaults.
		71 – 75	→	Full Luminaire Reboot. This command will reset all processors in fixture, then ReCal all parameters.
		76 – 80	→	
		81 – 85	→	Fixture Status On/Off. This command will enable the display to show fixture status for 5 min. After this time, displays will return to default configuration.
		86 – 90	→	Repeating this command in less than 5 minutes will behave as a toggle.
		91 - 255	→	Standard Mode - Fixture operates at maximum output (Default)
				Studio Mode - Reduced output with lower fan settings
				Reserved Values

Notes:

- Default Values: Denotes recommended console default settings.
- Use of Timing Channels: The default value setting in the profile should be 255 (proportional control) to allow smooth movement when using console timing. The Timing channel data should change as a snap. A zero value will give the fastest move but without any smoothing, this can look steppy in console-timed moves.
- To use a timing channel instead of console timing it is necessary to set the timing channel to the desired value and set cue and/or parameter time to zero. A combination of time controls can produce unexpected results. Refer to [“VLZ PROFILE Timing Channel Information” on page 36](#) for more information.
- Timing Channel Control: The luminaire uses the timing channel value to calculate a smooth continuous movement for a given time and transition.

## VLZ PROFILE Control Channel Functions

Control channel functions allow special actions such as reset and partial recalibration. These must be executed with zero time transition or with timing disabled. Discrete values must be used; not manual controls such as faders or encoders (see chart below for values).

**Reset** - resets all luminaire mechanisms.

**Partial Recalibration** - resets only the target mechanism (color, gobo, zoom, etc.) without affecting others.

Table 3-2: VLZ PROFILE Control Channel

DMX Channel	Parameter	Range DMX	Defaults	Description
61	<b>Luminaire Control</b>	0 – 255	0	Control Channel used for full fixture settings, lamp controls, and miscellaneous modes.  Set discreet value of desired effect, wait >3 seconds, then set value to 0 (Idle).
		0 - 5	→	Idle (Default)
		6 - 10	→	Full Luminaire ReCal - Also Used to Wake fixture up from shutdown
		11 - 15	→	Reserved Values
		16 - 20	→	Reserved Values
		21 - 25	→	Fixture Shutdown
		26 - 30	→	Display - Menu ON
		31 - 35	→	Display - Menu OFF
		36 - 40	→	ReCal Position
		41 - 45	→	ReCal Color
		46 - 50	→	ReCal Gobo
		51 - 55	→	ReCal Beam
		56 - 60	→	ReCal Optics
		61 - 65	→	Reserved Values
		66 - 70	→	Reset Fixture to Defaults - See Manual for a list of factory defaults.
		71 - 75	→	Full Luminaire Reboot. This command will reset all processors in fixture, then ReCal all parameters.
		76 - 80	→	Fixture Status On/Off. This command will enable the display to show fixture status for 5 min. After this time, displays will return to default configuration. Repeating this command in less than 5 minutes will behave as a toggle.
		81 - 85	→	Standard Mode - Fixture operates at maximum output (Default)
		86 - 90	→	Studio Mode - Reduced output with lower fan settings
		91 - 255	→	Reserved Values

---

To use control channel functions:

Step 1. Select an action to be sent.

Step 2. Set control channel value for desired action (for example, 36 for ReCal). Hold value for 3 seconds.

Step 3. Set control channel value to zero. (This must occur without any scaling values. Action will be voided if other values are detected between action value and zero.)

---

**Note:** A numerical keypad is suggested for sending values. An encoder or fader does not allow for a quick value change, which is required to effect the control functions.

---

# VLZ PROFILE DMX Mapping

## VLZ PROFILE Color Control

The luminaire’s color system is composed of a CMY color mixing mechanism and one fixed color wheel. The follow sections describe these components.

### Color Mixing

The color mixing mechanism is made up of four graduated color disks: cyan, magenta, yellow and CTO (color temperature orange). These disks provide full-spectrum color crossfades from pastel to saturated color.

**Table 3-3: DMX Map for Cyan, Magenta, Yellow and CTO Colors**

DMX Channel	Parameter	Range DMX	Defaults	Description
12 13	<b>Cyan</b> High Byte Low Byte	0 - 65535	0	16 Bit control of cyan color mechanism.
14 15	<b>Yellow</b> High Byte Low Byte	0 - 65535	0	16 Bit control of yellow color mechanism.
16 17	<b>Magenta</b> High Byte Low Byte	0 - 65535	0	16 Bit control of Magenta color mechanism.
18 19	<b>CTO</b> High Byte Low Byte	0 - 65535	0	16 Bit control of CTO mechanism.

### Fixed Color Wheel

Fixed color wheel offers timed changes, half and full frame positions, and various spin rates in either direction. The wheel contains six positions, one being open. The following illustration (Figure 3-1) shows the standard positions and color configuration for fixed color wheel:

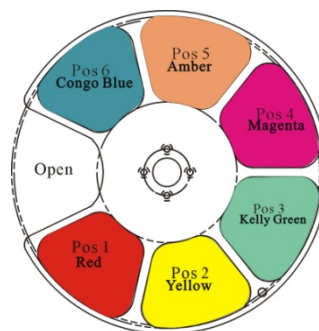

**Note:** Color are simulated and are for position reference only.

**Figure 3-1: Fixed Color Wheel Standard Filters / Positions**

**Table 3-4: VLZ PROFILE Fixed Color Wheel Standard Configuration Chart**

Position	Color Filter	Part Number
1	Red	6.03.05.03.2519
2	Yellow	6.03.05.03.2520
3	Kelly Green	6.03.05.03.2521
4	Magenta	6.03.05.03.2522
5	Amber	6.03.05.03.2523
6	Congo Blue	6.03.05.03.2524

## Fixed Color Wheel DMX Map

**Table 3-5: VLZ PROFILE DMX Map for Fixed Color Wheel**

DMX Channel	Parameter	Range DMX	Defaults	Description
20	<b>Color Wheel 1</b>	0 – 255 0 – 17 18 – 43 44 – 83 84 – 118 119 – 155 156 – 192 193 – 225 226 - 255	0 → → → → → → → →	8-bit linear control of Color Wheel 1. See Channel 16 for options. OPEN COLOR 1 - RED (Center at DMX 35) COLOR 2 - YELLOW (Center at DMX 71) COLOR 3 - KELLY GREEN (Center at DMX 107) COLOR 4 - MAGENTA (Center at DMX 143) COLOR 5 - AMBER (Center at DMX 179) COLOR 6 - CONGO BLUE (Center at DMX 215) OPEN END - NO COLOR

## VLZ PROFILE Beam Control

### Strobe

**Table 3-6: VLZ PROFILE DMX Map for Strobe**

DMX Channel	Parameter	Range DMX	Defaults	Description
55	<b>Strobe</b>	0 – 255 0 - 3 4 - 6 7 - 32 33 - 58 59 - 84 85 - 110 111 - 136 137 – 162 163 – 188 189 – 214 215 - 240	0 → → → → → → → → → → →	Controls Strobe functionality. Open Closed Normal Strobe - Slow to Fast Random Strobe - Slow to Fast Random Sync - Slow to Fast Pulse > - Slow to Fast Pulse > Random - Slow to Fast Pulse > Random Sync - Slow to Fast Pulse < - Slow to Fast Pulse < Random - Slow to Fast Pulse < Random Sync - Slow to Fast

## VLZ PROFILE Gobo/Effects Control

### Overview of Gobos used in VLZ PROFILE Luminaire

Due to the immense energy and light produced by VLZ PROFILE luminaires, Vari-Lite recommends to users and owners of this fixture follow the guidelines outlined below when loading gobos in any of the two rotating gobo wheels.

### Gobo Use and Positioning

Vari-Lite has purposely selected a set of standard gobos and gags for this fixture and positioned them within the fixture to offer optimum versatility / performance. The gobos supplied - in the standard factory configuration - have been tested in their respective original positions to protect their service life (including when morphed between wheels 1 and 2).

---

**Note:** For standard factory goboloads and position, please refer to the information contained in [“Gobo Wheels 1, and 2” on page 29](#) of this manual.

---

Users can load their own patterns (gobos). When using custom gobos, Vari-Lite recommends the following guidelines:

- Rotating gobo wheel 1 and 2 have been designated the effects wheel. Should only house clear type gags or gobos that permit minimum unabated light transmission.
- Under no circumstances should owners or users use or install metal gobos. Using metal gobos in the VLZ PROFILE luminaire will void the fixture's warranty.



---

**Note:** Vari-Lite cannot guarantee the service life of any custom gobos when used in conjunction with this fixture. Owners and users employing custom gobos do so at their own risk.

---

## Gobo Wheels 1 and 2

These wheels have five positions, one being open. Figure 3-2 illustrates the standard gobo configurations:

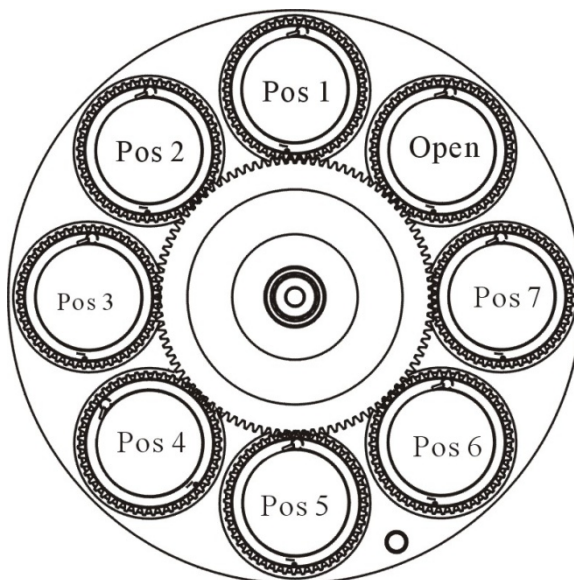

Figure 3-2: Gobo Wheels 1 and 2 Positions

For each wheel and their associated standard gobo, refer to:

[“VLZ SPOT Gobo Wheel 1 Standard Configuration Chart” on page 33.](#)

[“VLZ SPOT Gobo Wheel 2 Standard Configuration Chart” on page 33.](#)

**Table 3-7: VLZ PROFILE Gobo Wheel 1 Standard Configuration Chart**

Position	Gobo Style	Part Number
	Open	No Gobo
1	Nigh Sky	6.03.03.01.0615
2	Circle of Ovals	6.03.03.01.0616
3	Bricked out	6.03.03.01.0617
4	Punch Card	6.03.03.01.0618
5	Alpha Rays	6.03.03.01.0619
6	Honey Comb	6.03.03.01.0620
7	On the Rocks	6.03.03.03.0051

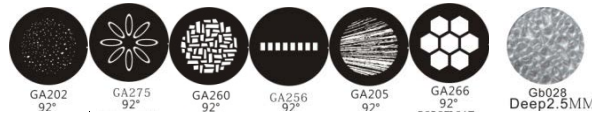

**Note:** Raw artwork shown for gobos and gags is for reference only.

**Table 3-8: VLZ PROFILE Gobo Wheel 2 Standard Configuration Chart**

Position	Gobo Style	Part Number
	Open	No Gobo
1	Leafy Breakup	6.03.03.01.0608
2	Medium Circle	6.03.03.01.0609
3	Lattice	6.03.03.01.0610
4	Swirl	6.03.03.01.0611
5	Radial Breakup	6.03.03.01.0612
6	Neurons	6.03.03.01.0613
7	Grid	6.03.03.01.0614

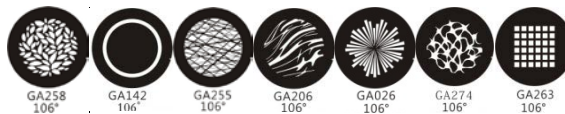

**Note:** Raw artwork shown for gobos and gags is for reference only.



## Index and Rotation

The gobo wheels operate in two modes: INDEX Mode and ROTATE Mode. The corresponding values are given in the DMX Map Tables below. Gobos will also behave as follows:

- Gobo wheels will only stop at whole images.
- Timed moves are only available using the Gobo Time channel.
- Spins are variable from DMX 0-126 for CCW fast to slow, and 129-255 for CW slow to fast.
- The Gobo Index function utilizes 8-bit control which offers enhanced resolution whether in INDEX or ROTATE mode.

**Table 3-9: VLZ SPOT DMX Map for Gobo Wheel 1 and 2**

DMX Channel	Parameter	Range DMX	Defaults	Description
22	<b>Gobo Wheel 1</b> (Fixed Gobo Wheel)	0 - 255	0	8-bit control of Gobo Wheel 1. See Channel 23 for control options.
		0 - 27	→	Open - No Gobo
		28 - 55	→	Gobo 1 - LEAFY BREAKUP
		56 - 83	→	Gobo 2 - MEDIUM CIRCLE
		84 - 111	→	Gobo 3 - LATTICE
		112 - 139	→	Gobo 4 - SWIRL
		140 - 167	→	Gobo 5 - RADIAL BREAKUP
		168 - 195	→	Gobo 6 - NEURONS
		196 - 223	→	Gobo 7 - GRID
		224 - 255	→	Open End - No Gobo
28	<b>Gobo Wheel 2</b> (Rotating Gobo Wheel)	0 - 255	0	8-bit control of Gobo Wheel 2. See Channel 27 for control options.
		0 - 5	→	Open - No Gobo
		6 - 10	→	Gobo 1 (Night Sky) Index
		11 - 15	→	Gobo 2 (Circle of Ovals) Index
		16 - 20	→	Gobo 3 (Bricked Out) Index
		21 - 25	→	Gobo 4 (Punch Card) Index
		26 - 30	→	Gobo 5 (Alpha Rays) Index
		31 - 35	→	Gobo 6 (HONEYCOMB) Index
		36 - 40	→	Gobo 7 (On the Rocks) Index
		41 - 45	→	Open - No Gobo
		46 - 50	→	Gobo 1 (Night Sky) Rotate
		51 - 55	→	Gobo 2 (Circle of Ovals) Rotate
		56 - 60	→	Gobo 3 (Bricked Out) Rotate
		61 - 65	→	Gobo 4 (Punch Card) Rotate
		66 - 70	→	Gobo 5 (Alpha Rays) Rotate
		71 - 75	→	Gobo 6 (HONEYCOMB) Rotate
		76 - 80	→	Gobo 7 (On the Rocks) Rotate

**Table 3-10: VLZ PROFILE DMX Map for Gobo Wheel 1 and 2**

		81 - 85	→	Open - No Gobo
		86 - 90	→	Gobo 1 (Night Sky) Rotate with Mega Stepping
		91 - 95	→	Gobo 2 (Circle of Ovals) Rotate with Mega Stepping
		96 - 100	→	Gobo 3 (Bricked Out) Rotate with Mega Stepping
		101 - 105	→	Gobo 4 (Punch Card) Rotate with Mega Stepping
		106 - 110	→	Gobo 5 (Alpha Rays) Rotate with Mega Stepping
		111 - 115	→	Gobo 6 (HONEYCOMB) Rotate with Mega Stepping
		116 - 120	→	Gobo 7 (On the Rocks) Rotate with Mega Stepping
		121 - 255	→	Reserved Values

# VLZ PROFILE Luminaire Timing

## VLZ PROFILE Timing Channel Information

Timing channel control improves the timed moves of certain groups of parameters. We provide up to four timing channels - Focus (pan and tilt), Optics Time (lens), Color Time (color parameters), Beam Time (beam parameters), and Gobo Time (gobo wheel operation).

Types of timing control:

- **Timing Control Channel:** the luminaire uses its timing channel value to calculate a smooth continuous movement for a given time and transition.
- **Console Timing:** the console calculates the time duration between the DMX increments to be sent for a given time and transition.

Guidelines:

- Timing channels support time values of up to six minutes.
- To use a timing channel instead of console timing, it is necessary to set the timing channel to the desired value and set cue and/or parameter time to zero. A combination of time controls can produce unexpected results.
- The default value setting in the profile should be 255 (proportional control) to allow smooth movement when using console timing.
- The timing channel data should change as a snap. A zero value will give the fastest move, however, without any smoothing this can appear "steppy" in console timed moves.

**Note:** Some parameters have been excluded from the timing channels. Wheel spin and gobo rotation rate changes are not affected by timing channels.

Table 3-11: VLZ PROFILE Luminaire Channel Function / Timing Channel Relationship

DMX Channel	Parameter	Range DMX	Defaults	Description
56	<b>Focus Timing</b>	0 - 255	255	Adjustment of fixture timing to control Pan/Tilt mechanisms. - See Timing Channel Chart in User Manual
57	<b>Optics Timing</b>	0 - 255	255	Adjustment of fixture timing to control lensing mechanisms. - See Timing Channel Chart in User Manual
58	<b>Color Timing</b>	0 - 255	255	Adjustment of fixture timing to control color mechanisms. - See Timing Channel Chart in User Manual
59	<b>Beam Timing</b>	0 - 255	255	Adjustment of fixture timing to control beam shaping mechanisms. - See Timing Chan
60	<b>Gobo Timing</b>	0 - 255	255	Adjustment of fixture timing to control gobo mechanisms. - See Timing Channel Chart in User Manual

A timing value of zero is full speed. A time value of 100% (or DMX 255) enables the associated parameter(s) to follow cue fade time (console time) rather than the timing channel.

---

**Note:** The particular storing syntax for your console, as well as instructions on how to write part cues, can be found in the operation manual for that console.

---

**To use these channels, you must:**

Step 1. Create the cue, including color, gobo, edge and frost as required.

Step 2. Decide which fixtures and which parameter groups will use timing channels.

Step 3. Assign a value to the particular timing channel(s) you wish to use (for timing information, see chart on next page).

Step 4. Set console timing (or cue fade time) for parameters and timing channels to zero seconds.

Step 5. Store cue.

---

**Note:** Avoid changing timing channel values in a fading cue. This can cause unexpected behavior in the luminaire as the timing channel value is updated over time. Timing channel values and the final destination of the parameters affected by the timing channel should always be sent in a zero count.

---

# Updating Software

---

## **Transferring Software from Luminaire to Luminaire**

It is possible to transfer specific software versions between luminaires. As in the case of installing new software versions, multiple luminaires can be programmed at the same time if they are data linked together (refer to [“Connecting Data and Power” on page 11](#)), however a maximum of 32 luminaires can be updated at once.

Hardware Requirements

---

A DMX termination connector is used in this process. Refer to page 11 for more information regarding the construction of this connector.

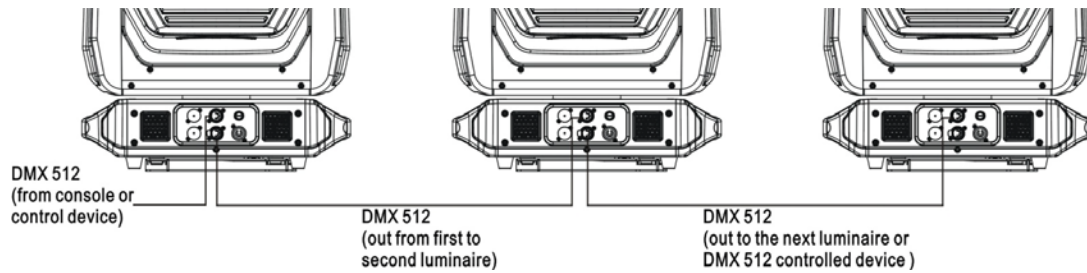

**Figure 3-4: Software Transfer Setup**

### Transfer Procedure

This procedure is used to transfer software versions between luminaires.

Step 1. At last luminaire, install DMX termination connector into DATA THRU XLR connector.

Step 2. At master luminaire (first in chain) Menu Display, press [MODE/ESC].

Step 3. Press arrows until Fixture appears.

Step 4. Press arrows until Crossload appears. Press .

Step 5. Unplug DMX From Console? will be displayed. Press to accept.

Step 6. Once download is complete, luminaire will automatically recalibrate. Once recalibration is complete, recalibrate luminaire one additional time.

### Verify software version at luminaire:

Step 1. At Menu Display, press [MODE/ESC].

Step 2. Press arrows until Fixture appears. Press .

Step 3. Press arrows until Version appears. Press .

Part 1 of the version will be displayed as VXXX.

Press [Enter] to display part 2 of version. This will be displayed as a date (MM/DD/YY). For example, 03/18/ 17 (March 18, 2017).

Press [Enter] to display part 3 of version. This will be displayed as a time(HH:MM). For example, 16.36 = 4:36 pm)

Notes

## CHAPTER 4.

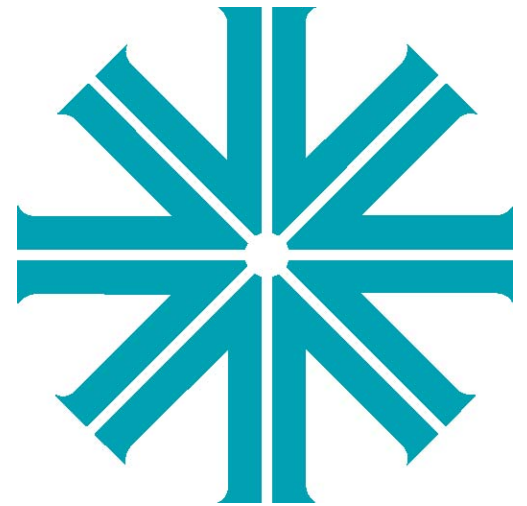

### **Menu System**

This chapter contains instructions for operating the luminaire using the Menu Display feature.

- **Menu Operation**
- **Menu Functions**
- **Self-Tests**



# Menu Operation

## What Is the Menu System?

The menu system is a programmable set of commands used to configure, address, operate, and test the luminaire. The menu system is controlled at the Menu Display available at the enclosure input panel.



Figure 4-1: Menu Display Location

## Controls Operation

The menu system is controlled by an MODE/ESC, , and four Arrow (, , , ) buttons. These buttons function are shown in Figure 4-2.

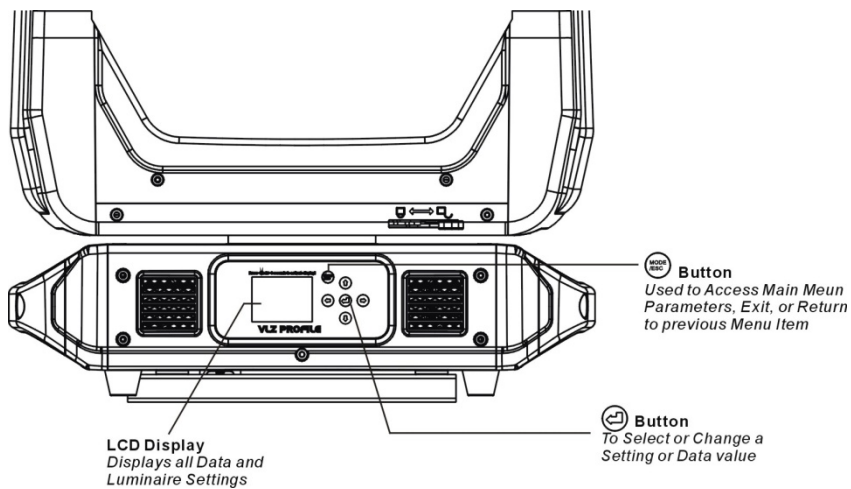

Figure 4-2: Menu Display Location

\* The arrows will have opposite functions if the luminaire is hung upside down in a hanging orientation due to the automatic orientation feature. In other words, the arrow pointing downward always functions as down/decrease and the arrow pointing upward always functions as up/increase regardless of the luminaire orientation.

---

## Default State

The menu display's default state during normal operation is to display the DMX address. After 40 seconds of inactivity at the display, it will change to the default state.





After longer periods of inactivity, the menu display will switch to its off state. The default state for this feature is 30 seconds, however, different time lengths can also be programmed.





To program a different time length for menu off feature:





Step 1. Press [MODE/ESC] access the main menu.





Step 2. Once enabled, the menu will function as normal with only the following sub-menu sections active:

- Address
- Configure
- DMX
- Fixture
- Manual Control
- Test

Step 3. Press     choose the "Configure", and press .

Step 4. Press     choose the "Display", and press .

Step 5. Press     choose the "On Time", and press .

Step 6. Press     choose "30 Sec", "5 Min", "10 Min", "On" when you need.

---

# Menu Functions

## VLZ PROFILE Menu System Function Chart

Table 4-1: VLZ PROFILE Menu System Chart

Address	001~512			(Default 001)
Configure	LED	Power Level	Standard	(Default)
			Studio	
		Refresh Freq	900~25000Hz	(Default 1200Hz)
		Gamma	2.0~2.8	(Default 2.0)
	Pan/Tilt	Movement	Enable	(Default)
			Disable	
		Speed	Normal VLZ Match	(Default)
	Head Motors	Movement	Enable	(Default)
			Disable	
	Display	Orientation	Auto	(Default)
			Up	
			Down	
		On Time	30 Sec	(Default )
			5 Min	
			10 Min	
	On			
	Reset Defaults	Are you sure?		
	Select Signal	DMX Only		(Default)
		Art-Net On IP2		
		Art-Net On IP10		
	Set Artnet	Set Universe	000~255	(Default 000)
		Ethernet IP	XXX. XXX. XXX. XXX	
		Ether Mask IP	XXX. XXX. XXX. XXX	
DMX	Data	Ch 1 - Intensity XXX (Value)		
		Ch 2 - Intensity Fine XXX (Value)		
		.....		
	Pan/Tilt	Swap Pan/Tilt	Off	(Default)
			On	
		Invert Pan	Off	(Default)
			On	
		Invert Tilt	Off	(Default)
	On			
	DMX Mode	16-bit Enh		(Default)
16-bit				

**Table 4-1: VLZ PROFILE Menu System Chart**

Fixture	Status	<i>(No Errors... or displays a list of errors)</i>		
	Recalibrate <i>(Fixture)</i>	Are you sure?		
	Reboot Fixture	Are you sure?		
	Version	VXXX	MM/DD/YY	HH:MM
	Fixture Hours	XXXXXX h		
	Crossload <i>(Software)</i>	Unplug DMX From Console?		
	Service	Service Settings	Set Position Cal	Pan
				Tilt
				Re. Pos. Offset
				ReCal Position
			Color Offset	Cyan
				Magenta
				Yellow
				CTO
				Color Wheel1
				Re. Col. Offset
				ReCal Color
			Gobo Offset	Fix Gobo
				Rot Gobo
				Gobo Rot
				Animat
Re. Gobo Offset				
ReCal Gobo				
Beam Offset			Iris	
			Frame 1A	
			Frame 1B	
	Frame 2A			
	Frame 2B			
	Frame 3A			
	Frame 3B			
	Frame 4A			
	Frame 4B			
	Frame Rot			
	Re. Beam Offset			
ReCal Beam				
Optics Offset	Edge			
	Zoom			
	Prism			
	Prism Rot			
	Frost 1			
	Frost 2			
	Re. Opt. Offset			
ReCal Optics				

**Table 4-1: VLZ PROFILE Menu System Chart**

		Diagnostics	Fan Check	
			Board Check	
			Sensor Check	
			Debug	
Manual Control	Intensity	Value 0 - 255		(Default 0)
	Intensity fine	Value 0 - 255		(Default 0)
	.....	.....		(Default 0)
Test	All Test	(Run 'ALL TEST' )		
	Pan/Tilt Test	(Run 'PAN/TILT TEST')		
	Test Channel	Intensity		<i>(Run Intensity test)</i>
		Pan		<i>(runPan test)</i>
		.....		.....
	Encoder Pan	XXXXXXXX - Displays Pan Encoder		
Encoder Tilt	XXXXXXXX - Displays Tilt Encoder			

---

### **Menu Function Definitions**

For easy reference, each possible menu item is listed alphabetically in the first column by its display abbreviation. The second column follows with a definition of the abbreviation and then a third column provides an explanation of its purpose and function.

---

## Self-Tests

---

### Running Parameter Tests

The luminaire is capable of running self-tests by using the Test menu functions.

When running tests on multiple luminaires, a DMX termination connector is required at the last luminaire in the link. Refer to [“Connecting Data and Power” on page 11](#) for more information regarding the construction of this connector.

---

**Note:** After 10 seconds of inactivity, the menu display will change to the default state showing the address.

---

---

Notes



# APPENDIX A

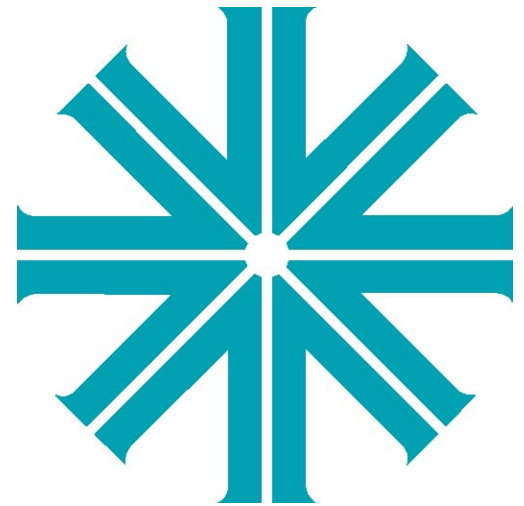

## **Luminaire Care and Routine Maintenance**

This appendix provides instructions for troubleshooting and routine maintenance which may be necessary during the life of the luminaire.

- **Equipment Handling**
- **Troubleshooting**
- **Routine Maintenance**



---

---

**WARNING:** All maintenance procedures are to be performed with power removed from the luminaire. Never remove covers or back cap while LED is in operation.

---

---

# Equipment Handling



---

## **Below are some basic tips and information on handling luminaires and their associated components. Locations/Use**

VARI\*LITE luminaires are designed for dry locations only. Exposure to rain or moisture (including, but not limited to, fog machines, misters, etc.,) may damage luminaire.

---

### **LED**

The Atria SUL series bring the more cost-effective high power LED engines to entertainment lighting with high brightness, compact size and excellent thermal management. Proprietary technology in secondary optics delivery high directional lighting with concentrate emitting angle, which makes maximum lighting efficiency available in lighting fixture.

### **Servicing**

- When handling a LED, hold it by the ceramic base while wearing cotton gloves or finger cots. Do not touch the glass envelope. If you touch the glass with bare fingers, immediately wipe off any fingerprints with isopropyl alcohol.
- Use care when opening and closing the rear castings (or covers) of luminaires and cleaning reflectors.

### **Heat**

When LED are lit, the interior of the luminaires becomes very hot. To aid in the airflow circulation within the luminaires, after dousing the LED, wait ten minutes before removing power to the luminaires. This will provide enough time for the equipment fan to cool off the unit. Users should wait until the unit is cool to the touch before servicing or handling.

### **LED Features/Benefits**

- Extremely high lm/mm<sup>2</sup>
- Small aperture size and ultra-narrow lighting emitting angle
- Compact LED-engine solution with unique secondary optics mounted
- High Color rendering index is available
- Reliable packaging with advanced thermal management
- Lumen maintenance of greater than 70% after 20,000 hours
- Most cost-effective solution in the same level performance of LED engine

Note:Based on CW driver current. Sustained operation beyond recommended drive current values may result in reduced life time. Normal operating thermistor resistance should stay within recommended limits. Lifetime depends on thermal management. Input power and thermal system must be properly managed to ensure life time.

A

---

## Solid State Electronics



### Electrostatic Discharge (ESD)

Electrostatic discharge (ESD) presents a significant danger to solid state electronic components (semiconductor devices and PC board assemblies). Static electricity can build on a variety of common objects (including people) simply by handling or moving. ESD rarely results in immediate failure of a component, but shows up later as an intermittent problem or severely reduces the life of the component. All VARI\*LITE equipment uses solid state electronics and appropriate precautions to protect them should be observed when servicing.

### Printed Circuit Boards (PCBs)

All PC boards should be shipped in electrostatic shielding bags. When handling PC boards or components, devices such as conductive mats and conductive wrist straps should be used whenever possible. If these precautionary devices are not available, handling of PC boards and components should be avoided.



---

**CAUTION:** Black foam (used to package solid state electronics) should never be used for packing batteries or put in contact with PC boards which contain batteries.

---

# Troubleshooting

## Error Messages

If a problem occurs during luminaire calibration, at the end of the calibration sequence the Menu Display will cycle through any applicable error message(s) until the end of the list is reached. To review the error messages again, it will be necessary to access them using the Status function.

To access error messages:

Step 1. Press [MODE/ESC].

Step 2. Press     arrows until Fixture appears. Press .





Step 3. Press     arrows to access Status. Press . (Display will now scroll through any error messages or display OK if no errors.)

Table A-1: Error Messages

Display	Message
No Errors	No Errors Found
NO Sensor On Pan	Pan sensor not found,Pan ReCalibrate fail.
NO Sensor On Tilt	Tilt sensor not found,Tilt ReCalibrate fail.
NO Sensor On Cyan	Cyan sensor not found,Cyan ReCalibrate fail.
NO Sensor On Magenta	Magenta sensor not found,Magenta ReCalibrate fail.
NO Sensor On Yellow	Yellow sensor not found,Yellow ReCalibrate fail.
NO Sensor On CTO	CTO sensor not found,CTO ReCalibrate fail.
NO Sensor On Color Wheel	Color Wheel sensor not found,Color Wheel1 ReCalibrate fail.
NO Sensor On Fix Gobo	Fix Gobo sensor not found,Fix Gobo ReCalibrate fail.
NO Sensor On Rot Gobo	Rot Gobo sensor not found,Rot Gobo ReCalibrate fail.
NO Sensor On Gobo Rot	Gobo Rot sensor not found,Gobo Rot ReCalibrate fail.
NO Sensor On Animat	Animat sensor not found,Animat ReCalibrate fail.
NO Sensor On Prism	Prism sensor not found,Prism ReCalibrate fail.
NO Sensor On Prism Rot	Prism Rot sensor not found,Prism Rot ReCalibrate fail.
NO Sensor On Frost	Frost sensor not found,Frost ReCalibrate fail.
NO Sensor On Iris	Iris sensor not found,Iris ReCalibrate fail.
NO Sensor On Edge	Edge sensor not found,Edge ReCalibrate fail.
NO Sensor On Zoom	Zoom sensor not found,Zoom ReCalibrate fail.
NO Sensor On Frame 1A	Frame 1A sensor not found,Frame 1A ReCalibrate fail.
NO Sensor On Frame 2A	Frame 2A sensor not found,Frame 2A ReCalibrate fail.
NO Sensor On Frame 3A	Frame 3A sensor not found,Frame 3A ReCalibrate fail.
NO Sensor On Frame 4A	Frame 4A sensor not found,Frame 4A ReCalibrate fail.
NO Sensor On Frame 1B	Frame 1B sensor not found,Frame 1B ReCalibrate fail.
NO Sensor On Frame 2B	Frame 2B sensor not found,Frame 2B ReCalibrate fail.
NO Sensor On Frame 3B	Frame 3B sensor not found,Frame 3B ReCalibrate fail.
NO Sensor On Frame 4B	Frame 4B sensor not found,Frame 4B ReCalibrate fail.
NO Sensor On Frame Rot	Frame Rotate sensor not found,Frame Rotate ReCalibrate fail.

NO Sensor On Frost2	Frost2 sensor not found,Frost2 ReCalibrate fail.
Temp Error	Temperature sensor error
7U_FanFault1	Head Fan1 error
7U_FanFault2	Head Fan2 error

---

## Troubleshooting Guide

If a problem is suspected, first try recalibrating the luminaire to prompt an error message. The chart below provides possible causes and remedies for various error messages and/or symptoms.

# Routine Maintenance

---

## LED Replacement

---



**WARNING:** Ensure that power is removed from luminaire when installing LED.

---



**CAUTION:** Wear cotton gloves or other covering while installing LED. Touching LED glass with bare fingers will leave oil and may cause the LED to explode or reduce LED life. If touched, use alcohol and cotton cloth to thoroughly clean glass portion of LED.

---

To replace LED:

Step1: Ensure power is removed from luminaire.

Step2: At rear of luminaire head, loosen four Crossed Slot screws.

Step3: take out the LED.

Step4: Position new LED with dimple side down.

Step5: Re-tighten four Crossed Slot screws.

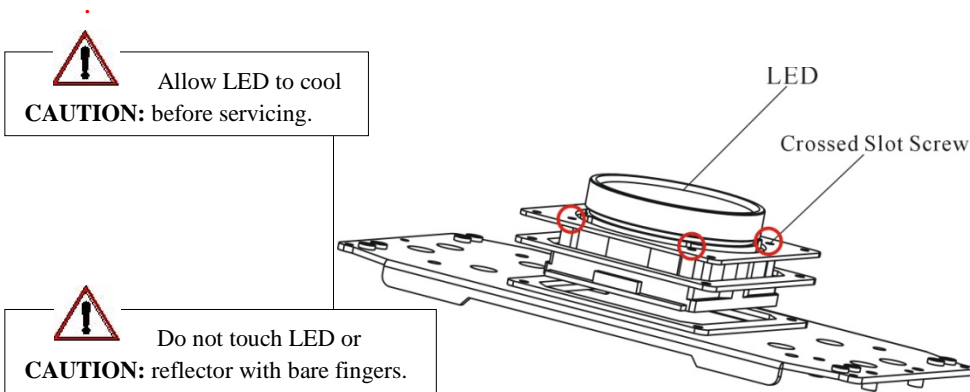

**Figure A-1: Installing LED**

---

## Gobo Replacement - Gobo Wheels

### Tools:

Crossed Slot screwdriver

### Overview of Gobos used in VLZ PROFILE Luminaire

Due to the immense energy and light produced by VLZ PROFILE luminaires, Vari-Lite recommends to users and owners of this fixture follow the guidelines outlined below when loading gobos in any of the three rotating gobo wheels.

### Gobo Use and Positioning

Vari-Lite has purposely selected a set of standard gobos for this fixture and positioned them within the fixture to offer optimum versatility / performance. The gobos supplied - in the standard factory configuration - have been tested in their respective original positions to protect their service life.

---

**Note:** For standard factory gobo / gag loads and position, please refer to [“VLZ PROFILE Gobo/ Effects Control” on page 31](#) of this manual.

---



**Note:** Vari-Lite cannot guarantee the service life of any custom gobos or gags when used in conjunction with this fixture. Owners and users employing custom gobos and gags do so at their own risk.

---

### To Install or Replace Gobos



---

**WARNING:** Remove power from luminaire before performing maintenance. Gobos may be HOT after operation. Allow to cool before replacing.

---

To replace a rotating gobo:

Step 1: Remove power from luminaire.

Step 2: As illustrated in Figure A-2, remove top and bottom head cover by loosening four Crossed Slot screws to access the gobos wheels.



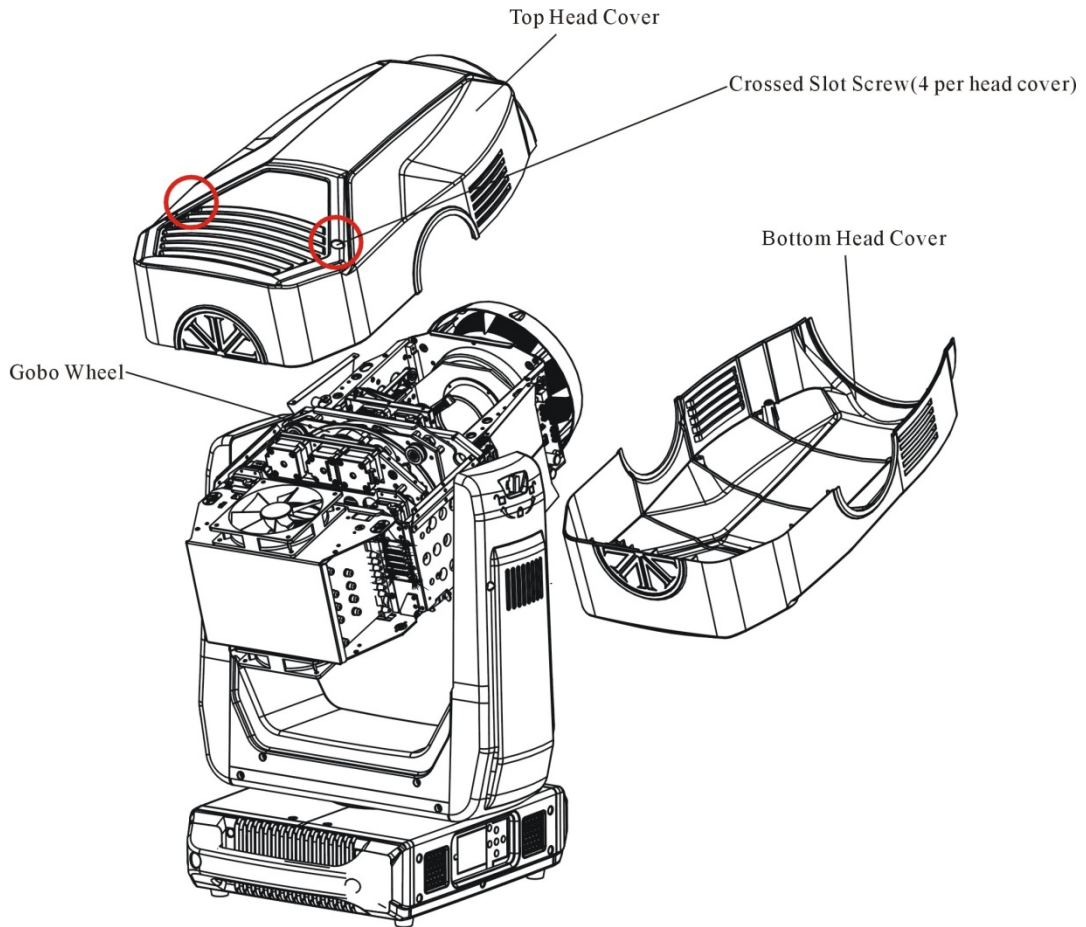

Figure A-2: Head Covers – Removal

Step 3. If removing gobos via bottom of head assembly, undo fan tray assembly with thumb screw to access.

Step 4. Rotate desired gobo wheel until required gobo position is accessible.



---

**CAUTION:** Do not push on gobo glass. Press on gobo carrier only.

---



---

**CAUTION:** Do not touch gobos with bare fingers. Wear cotton gloves or other covering while replacing. To clean, refer to [“Cleaning Optics, Filters and Gobos” on page 59.](#)

---

Step 5. Remove current gobo by carefully pressing on edges of gobo carrier with fingers, pressing gobo toward front end of luminaire (toward lens), and out of wheel.

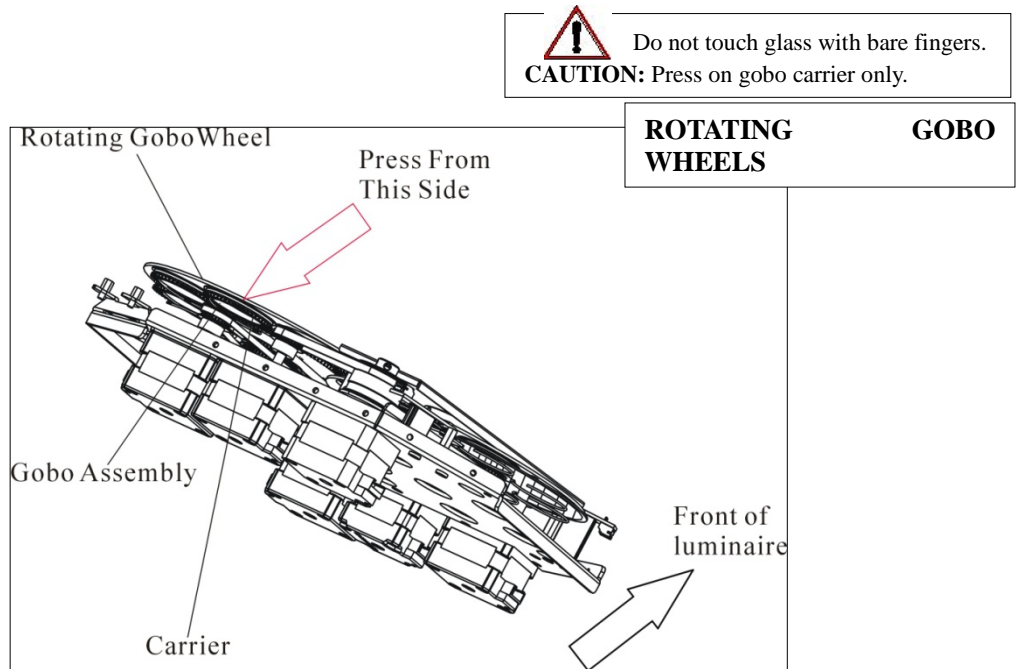

Figure A-3: Replacing Gobos

Step 6. Install new gobo as follows:

- a. Place the goboholder on a clean, flat work surface with the teeth facing upwards. The gobo is held in place in the goboholder by a spring. Taking care to avoid scratching or applying pressure to the gobo, lever the end of the spring out, remove the spring and then lift the gobo out of the goboholder.
- b. See illustration below. Hold the gobo with the dark side facing upwards towards the teeth in the goboholder. Match up the alignment marks (arrowed) in the gobo and goboholder. Lay the new gobo flat in the goboholder.

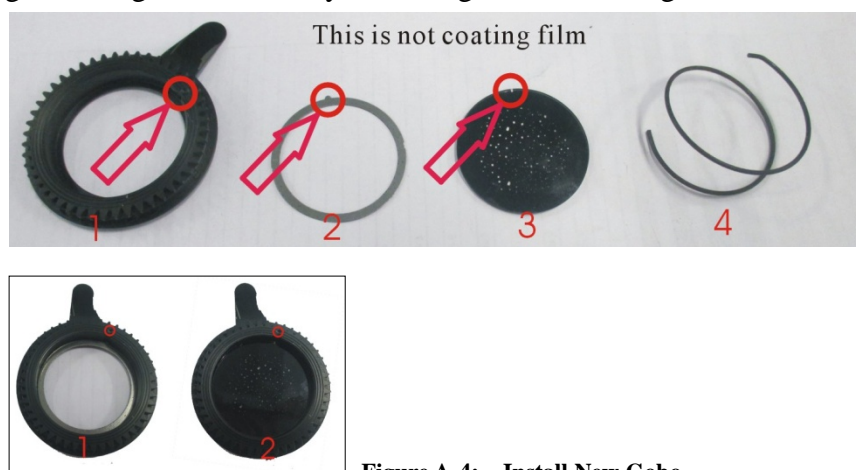

Figure A-4: Install New Gobo

- c. Insert gobo carrier into wheel, ensuring that carrier snaps into place.
- Step 7. Rotate desired gobo wheel until required gobo position is accessible.

---

## Cleaning Optics, Filters and Gobos



---

**WARNING:** Remove power from luminaire before performing maintenance.

---



---

**WARNING:** Acetone is a harsh cleaning agent and solvent. Acetone is very flammable. Please handle acetone according to manufacturer's safety instructions and precautions.

---

The front lens, optics/color filters, and reflector may require cleaning after extended use.

- **FRONT LENS:** Use a isopropyl alcohol with a soft, lint-free cloth to clean the front lens.
- **OPTICS/COLOR FILTERS/ GOBOS:** Use Acetone or Isopropyl Alcohol along with a soft, lint-free cloth to clean the optics/color filters.
- **REFLECTOR:** Use Acetone or Isopropyl Alcohol along with a soft, lint-free cloth to clean the reflector.



---

**CAUTION:** Do not continuously rub color filters or reflector - it may damage or remove the optical coating.

---

The VLZ PROFILE Luminaire can be hung horizontally or vertically from any structure designed to work with the type of load created by this moving luminaire. Two mounting truss hooks or other mounting hardware are required. Many compatible truss hooks are available from different manufacturers for your particular needs. A minimum of two hooks per luminaire is required. If mounting method does not use truss hooks, two attachment points, per luminaire, are required.

**Install mounting hardware and brackets:**

Step 1. Install truss hooks on two provided truss hook brackets as required as shown in Figure A-5.

Step 2. Determine required configuration of bracket installation. Brackets may be installed in many different orientations as shown in Figure A-6.

Step 3. While pulling up on locking mechanism release, fit keyed holes onto raised mounting buttons at bottom of enclosure. Slide forward and release locking mechanism to lock in place. Ensure brackets are locked securely.

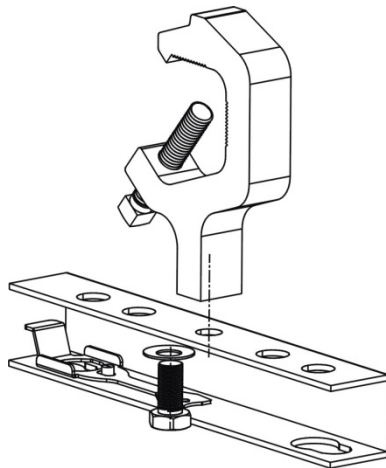
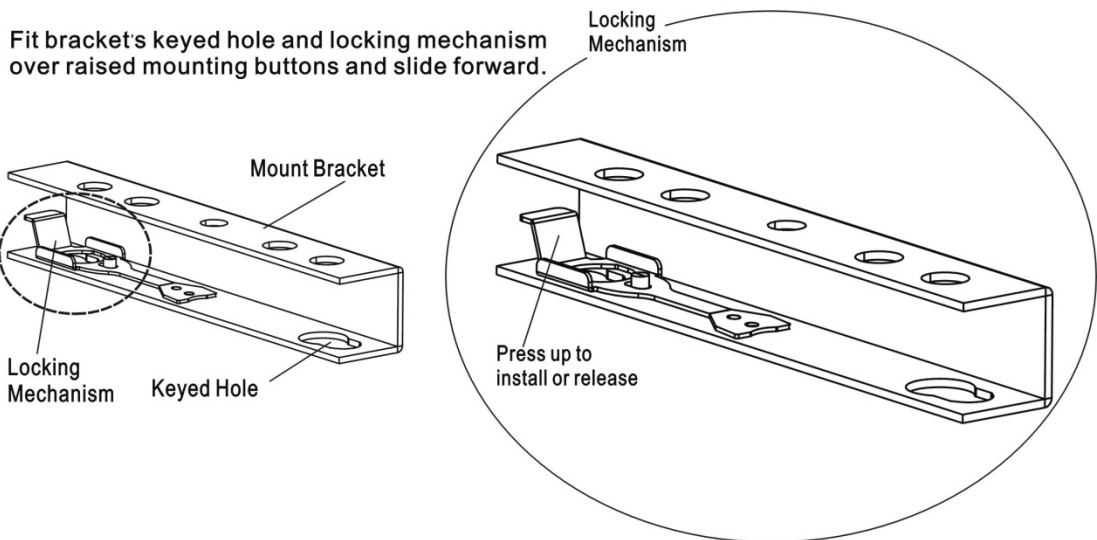
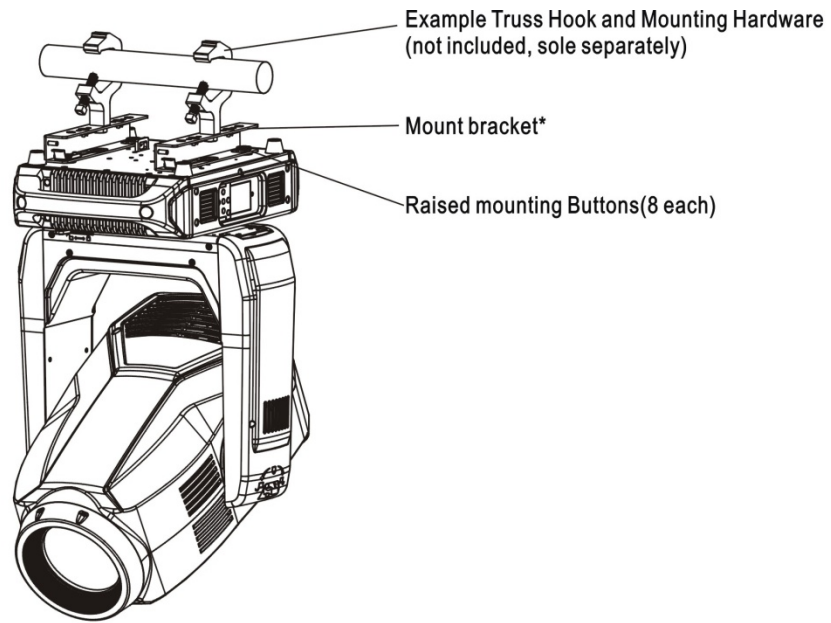

Figure A-5: Truss Hook Installation



**WARNING:** Ensure that the bracket locking mechanism is fully seated after the bracket is installed on the luminaire.

**AVERTISSEMENT:** Assurez-vous que le mécanisme de support de verrouillage est complètement inséré après le support est installé sur l'appareil.



**Figure A-6: Installing Brackets on Luminaire Enclosure**

---

Notes

# APPENDIX B



## Technical Specifications

---



### **VLZ PROFILE Luminaire**

#### **PROGRAMMABLE FUNCTIONS**

##### **Color System**

Six color control wheels total. A three filter CMY cross fading system, one fixed color wheel, and a variable CTO color temperature correction wheel.

##### **Zoom Optics**

Covering a range from 6.3° to 55°.

##### **Beam Size Control**

A mechanical iris provides continuous beam size control for rapid and smooth timed beam angle changes.

##### **Strobe**

High-performance dual blade strobe system capable of ultra-fast operation.

##### **Fixed and Rotating Gobo Wheels**

Two gobo/effects wheels combine to each offer seven rotatable, indexable gobo positions and one open position.

##### **Edge and Pattern Focus**

Variable beam focus to soften edges of gobos or spots. Remarkable depth of field capability allows morphing effects between all pattern and effects wheels.

##### **Variable Frost**

Independent, drop-in armature that holds variable frost glass.

##### **Rotating Prism**

Independent, drop-in armature which rotates and holds a 3-facet prism.

##### **Pan and Tilt**

Movement and Speed.

##### **Pan and Tilt Range**

Pan - 540°, Tilt - 270°

---

---





## **OPTICAL**

### **Source**

#### **Color Temperature**

7000K

#### **Output**

Standard Mode: 24,286 lumens

Studio Mode: 20,970lumens

#### **Gobo**

Metal gobos are not acceptable.



## **OPERATIONAL**

### **Power Requirements**

Standard AC power distribution from 100-240 VAC, 50/60 Hz. The unit requires up to 15 A depending on the AC supply voltage.

#### **Control**

Compatible with a wide variety of DMX512 consoles.

#### **DMX Channels**

61

#### **Mounting Position:**

The VLZ PROFILE luminaire can be mounted and operated in any orientation.

#### **Weight**

42.7kg



Dimensions

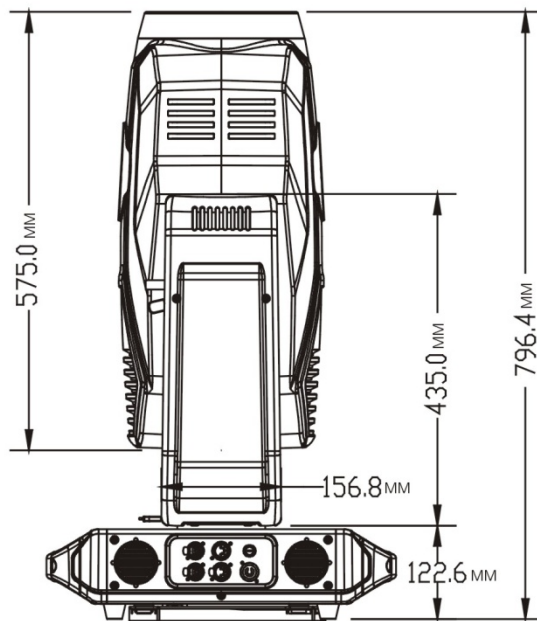
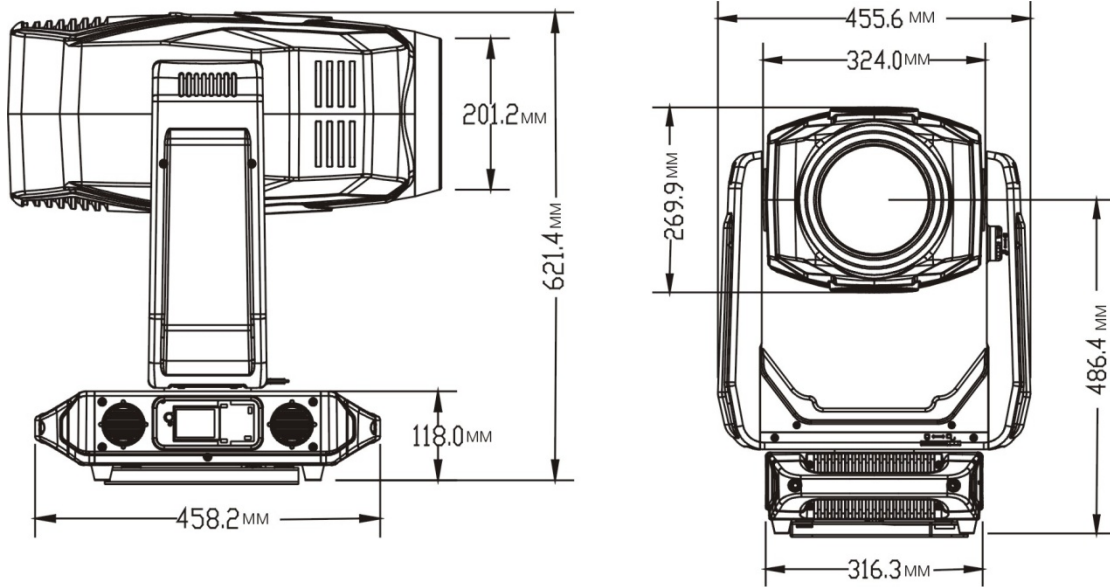

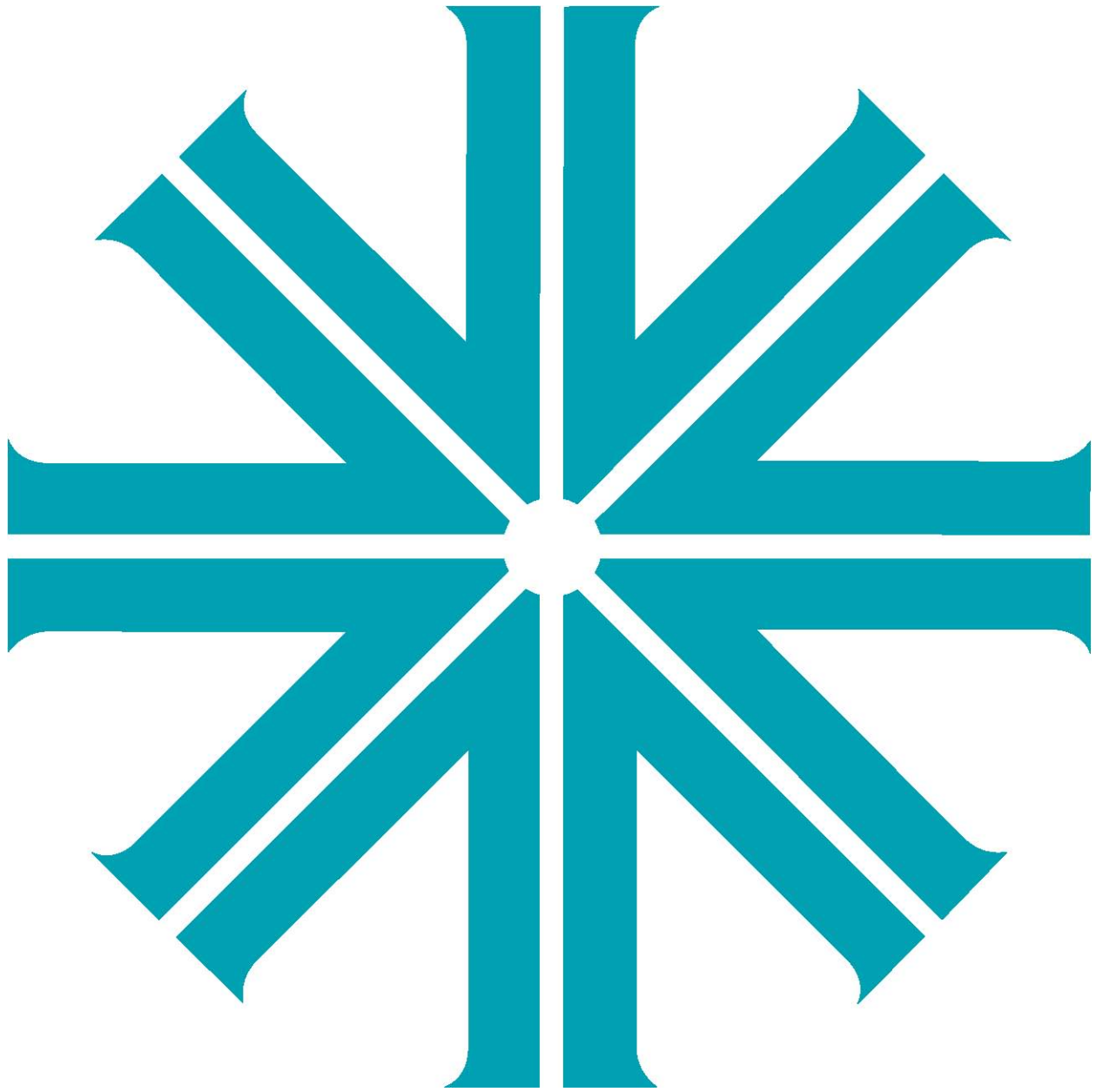



Philips Vari-Lite

10911 Petal Street

Dallas, Texas 75238 USA

1-877-VARI-LITE . 1-214-647-7880

<http://www.philips.com/entertainmentlighting>

©2013 Philips Vari-Lite, a Philips group company. All Rights Reserved.