

PHILIPS
VARI*LITE



**VLZ PROFILE Luminaire
QuickStart Guide**

Introduction

About This Guide

This Quickstart Guide is intended for a knowledgeable user to unpack, install, and use the VLZ PROFILE Luminaire in a short time period. For the complete manual in PDF format, please visit our web site at: www.vari-lite.com and click the user manual download link on the product downloads page. The complete manual provides you all information related to accessories, menu structures, DMX channel mapping/ modes, and care for your new luminaire.

Read this manual in its entirety before operating luminaire. Keep this guide for future reference.

WARNING: It is important to read ALL accompanying safety and installation instructions to avoid damage to the product and potential injury to yourself or others. **AVERTISSEMENT:** Il est important de lire toutes les instructions de sécurité et d'installation d'accompagnement pour éviter d'endommager le produit et les risques de blessures à vous-même ou les autres.

Notes:

- For complete product description, features, and specifications, refer to product specification sheet on the Vari-Lite web site at www.vari-lite.com.
 - For power requirements, refer to “**Current vs. Voltage**” on page 8”.
 - VLZ SPOT luminaires accept glass gobos only. Use of metal gobos will void the luminaire’s warranty.
-

Additional Documentation

For more information on installing DMX512 control systems, the following publication is available for purchase from the United States Institute for Theatre Technology (USITT), "Recommended Practice for DMX512: A Guide for Users and Installers, 2nd edition" (ISBN: 9780955703522). USITT Contact Information:

USITT

315 South Crouse Avenue, Suite 200
Syracuse, New York 13210-1844 USA
Phone: 800-938-7488 or +1-315-463-6463
Fax: 866-398-7488 or +1-315-463-6525
Web Site: www.usitt.org

Customer Service

Our Goal

At Vari-Lite, we are committed to providing you the highest quality in customer service. Our comprehensive resources are available to help your business succeed and ensure you get the full benefit of being a Vari-Lite customer. Whether your needs are telephone troubleshooting assistance, product training or technical service, our full-time staff of experienced professionals are on-hand to provide support.

How to Reach Us

For assistance in your area, call the dealer from which your product was purchased.

or Contact an Authorized Service Center

or Contact the Vari-Lite Customer Service Department, 7am - 6pm CST Monday through Friday, at the following:

phone: 1-877-VARI-LITE (1-877-827-4548) or +1-214-647-7880

e-mail: entertainment.service@philips.com

Note: Performing maintenance procedures may void the product warranty. Refer to the Vari-Lite Limited Warranty card included in the product shipping package for more information. For all service and maintenance issues, please contact your local Authorized VARI*LITE Dealer or Service Center.

Additional Resources

For additional resources and documentation on this product, please visit our website at www.vari-lite.com and follow the Support link.

Document Number: **02.9708.0001** Version as of: **10 January 2017**

VL6000 Beam Luminaire QuickStart Guide

©2016 Philips Group. All rights reserved.

Compliance & Safety Notices

FCC

Compliance

This equipment has been tested and found to comply with the limits for a Class A digital device pursuant to Part 15 of FCC Rules. These limits are designed to provide reasonable protection against harmful interference when this equipment is operated in a commercial environment. This equipment generates, uses, and can radiate radio frequency energy and, if not installed and used in accordance with Vari-Lite system, service, and safety guidelines, may cause harmful interference to radio communications.

As tested under this standard:

FCC 47CFR 15B cIA*CEI

Issued:2009/10/01 Title 47 CFR Part 15 Subpart B Unintentional Radiators Class A

Operation of this equipment in a residential area is likely to cause harmful interference, in which case the user will be required to correct the interference at his/her own expense.

CEC Declaration of Conformity

We, Philips Lighting B.V., 10911 Petal Street, Dallas, Texas 75238, declare under our responsibility for the products contained herein are in conformity with the essential requirements of the following European Directives and harmonized standards: Low Voltage Director (LVD), 2006/95/EC EN 60589-2-17:1984+A1:1987+A2:1990 used in conjunction with 60598-1:2008/A11:2009 Electromagnetic Compatibility Directive (EMC), 2004/108/EC EN 55022:2010, EN55024:2010

Safety Notice

It is extremely important to read ALL safety information and instructions provided in this manual and any accompanying documentation before installing and operating the products described herein. Heed all cautions and warnings during installation and use of this product. Safety symbols used throughout this manual are as follows:



CAUTION advising of potential damage to product.



WARNING advising of potential injury or death to persons.

GENERAL INFORMATION PERTAINING TO PROTECTION AGAINST ELECTRICAL SHOCK, FIRE, EXPOSURE TO EXCESSIVE UV RADIATION, AND INJURY TO PERSONS CAN BE FOUND BELOW.

WARNING: INSTRUCTIONS FOR CONTINUED PROTECTION AGAINST FIRE

- 1 Luminaires may be mounted on any type of surface as long as mounting instructions are followed. See instructions detailed in this manual.
- 2 Note distance requirement from combustible materials or illuminated objects for VARI*LITE luminaires.

WARNING: INSTRUCTIONS FOR CONTINUED PROTECTION AGAINST ELECTRICAL SHOCK

- 1 VARI*LITE luminaires are designed for dry locations only. Exposure to rain or moisture may damage luminaire.
- 2 Disconnect power before servicing any VARI*LITE equipment.
- 3 Servicing to be performed by qualified personnel only.

WARNING: INSTRUCTIONS FOR CONTINUED PROTECTION AGAINST EXCESSIVE EXPOSURE TO UV RADIATION

- 1 It is hazardous to operate luminaires without lens or shield. Shields, lenses, or ultraviolet screens shall be changed if they have become visibly damaged to such an extent that their effectiveness is impaired. For example, by cracks or deep scratches. Replace any cracked or protective shi



WARNING: INSTRUCTIONS FOR PROTECTION AGAINST INJURY TO PERSONS

1 Exterior surfaces of the luminaire will be hot during operation. Use appropriate safety equipment (gloves, eye protection, etc.) when handling and adjusting hot equipment and components.

WARNING: RF INTERFERENCE

This is a Class A product. In a domestic environment this product may cause radio interference, in which case, the user may be required to take adequate measures.

Notes de sécurité

Avant de procéder à l'installation des produits décrits dans ce guide et de les mettre en marche, il est extrêmement important de lire TOUS les renseignements et TOUTES les directives de sécurité contenues dans ce guide ainsi que toute documentation jointe. Tenir compte de tous les avertissements et suivre toutes les précautions pendant l'installation et l'utilisation de cet appareil. Les symboles de sécurité utilisés dans ce guide sont les suivants :



ATTENTION Ce symbole annonce que l'appareil risque d'être endommagé.



AVERTISSEMENT Ce symbole annonce qu'il y a risque d'accident grave ou même fatal.

CETTE SECTION CONTIENT DES INFORMATIONS GÉNÉRALES POUR SE PROTÉGER CONTRE LES DÉCHARGES ÉLECTRIQUES, LES INCENDIES, L'EXPOSITION EXCESSIVE AUX RAYONS UV ET TOUT AUTRE ACCIDENT POUVANT ENTRAÎNER DES BLESSURES.

AVERTISSEMENT: DIRECTIVES POUR SE PROTÉGER CONTRE LES INCENDIES

- 1 Les luminaires peuvent être fixés sur tout type de surface tant que les directives de montage sont respectées. Voir les explications détaillées dans ce guide.
- 2 Vérifier la distance à respecter entre les matériaux combustibles ou les objets illuminés et les luminaires VARI* LITE.

AVERTISSEMENT: DIRECTIVES POUR SE PROTÉGER CONTRE LES DÉCHARGES ÉLECTRIQUES

- 1 Débrancher l'appareil avant de procéder à la révision de tout matériel VARI* LITE.
- 2 Les révisions doivent être effectuées uniquement par des personnes qualifiées.

AVERTISSEMENT: DIRECTIVES POUR SE PROTÉGER CONTRE UNE EXPOSITION EXCESSIVE AUX RAYONS UV

- 1 L'utilisation des luminaires sans lentille ou blindage pose des risques. Tous blindages, lentilles ou écrans ultraviolet visiblement endommagés au point que leur efficacité en est affectée doivent être remplacés, par exemple s'il y a des fissures ou de profondes rayures.

AVERTISSEMENT: DIRECTIVES POUR SE PROTÉGER CONTRE LES ACCIDENTS POUVANT ENTRAÎNER DES BLESSURES

- 1 Les surfaces externes du luminaire deviennent brûlantes quand l'appareil est en marche. Pour manœuvrer ou ajuster des appareils brûlants et leurs composants, se protéger suffisamment (gants, protection pour les yeux, etc.).

AVERTISSEMENT:

INTERFÉRENCE RF

Cet appareil est de Classe A. Dans un environnement domestique, cet appareil peut causer des interférences radio, et si c'est le cas, l'utilisateur peut avoir à prendre des mesures adéquates.

Other

Battery Information / Informations sur la batterie

- This unit has a battery. Warning: Caution risk of explosion if battery is replaced by an incorrect type. Dispose of used batteries according to the instructions.
- Cet appareil dispose d'une batterie. Avertissement: Attention risque d'explosion si la batterie de remplacement par un type incorrect. Jetez les piles usagées selon les instructions.



About The VLZ PROFILE Luminaire Included Items

Included Items

The following illustration shows all items included with the luminaire:

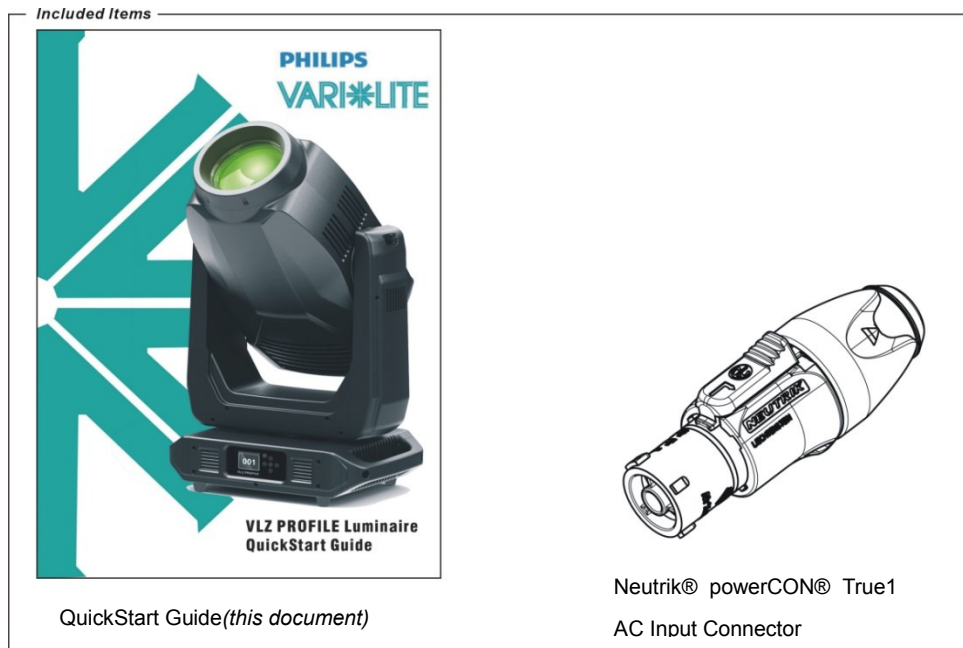

Figure 1: VLZ PROFILE Luminaire Included Items

Note: * Please Check with the local Philips Entertainment Office or Authorized Vari*Lite dealer for availability on accessories.

Connecting Power and Data

Connecting Power

The luminaire requires standard AC power distribution from AC100-240V~, 50/60Hz. Current required depends on the AC supply voltage and product model. Refer to “Current vs. Voltage” on page 8 for all models covered in this manual.

Note: The mating Neutrik® powerCON® True1 connector is supplied; however, you will need to purchase or construct a cable appropriate for your application.

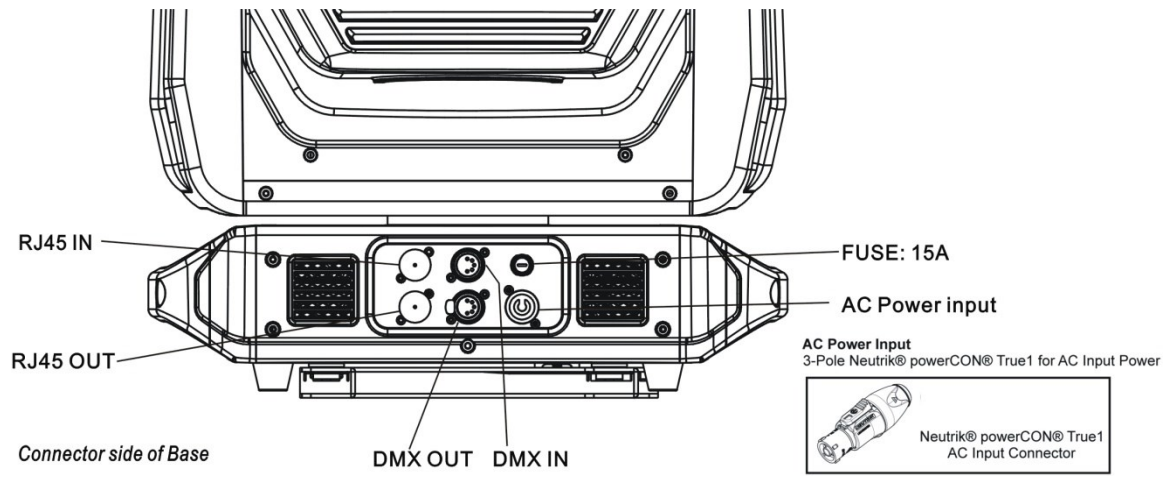

Figure 2: Power Connector

Depending on the application, the luminaire’s AC input cable may require a different connector. If required, install a new connector meeting your requirements using the following wire color code reference:

Wire*	Connection
Green	AC Ground
White	AC Neutral
Black	AC Line
* International (Harmonized) Standard	

WARNING: DO NOT connect to three-phase service in countries with 240 volt power. **AVERTISSEMENT:** NE PAS se connecter au service en trois phases dans les pays avec puissance de 240 volts.

For single-phase power at 240 volts RMS:

Connection	Pin
AC Neutral	X
AC Line	Y
Ground(Earth)	G



For three-phase power at 208 volts RMS:

Connection	Pin
Phase 1	X
Phase 2	Y
Ground (Earth)	G



WARNING: It is not recommended to power any VARI* LITE luminaire from a dimmer - even in 'NONDIM' mode. Dimmer and non-dim modules are not suitable sources of power because their output modifies the AC wave form. This may work for a short time, but will eventually result in power problems, luminaire mis-operation and/or failure and may void the luminaire's warranty.

AVERTISSEMENT: Il n'est pas recommandé pour alimenter un luminaire VARI* LITE d'un gradateur - même en mode 'NONDIM'. Modules de gradation et non sombres ne sont pas des sources appropriées de pouvoir parce que leur production modifie la forme d'onde AC. Cela peut fonctionner pendant une courte période, mais finira par entraîner des problèmes d'alimentation, luminaires mauvais fonctionnement et / ou l'échec et peut annuler la garantie de l'appareil.

Current vs. Voltage

AC Power Operation

When connected to an AC source, the unit operates on 100 to 240 volts AC (+/- 10%, auto-ranging). The luminaire contains an auto-ranging power supply. Each luminaire can draw up to 1000 Watts.

WARNING: It is the responsibility of the user to adequately protect supply source with a correct size and type circuit breaker and not overload circuits. **AVERTISSEMENT:** Il est de la responsabilité de l'utilisateur de protéger adéquatement la source d'alimentation avec une taille correcte et le disjoncteur de type et surchargez pas les circuits.

Connecting Data

A maximum of 61 luminaires may be connected in any one DMX data link.

Note: This maximum limit applies to the luminaire "daisy chain" only. Your system or console may require fewer luminaires on a single data link path. Consult your console documentation for more information.

To connect power and data:

Step 1. Connect data cable from console to first luminaire in chain at DATA IN connector.

Step 2. If required, connect additional data cables from DATA THRU connectors to DATA IN connectors of remaining luminaires in link.

Step 3. At last luminaire in link, install male termination connector at DATA THRU connector. (Luminaires and other devices on the same DMX chain may not function properly without termination.)

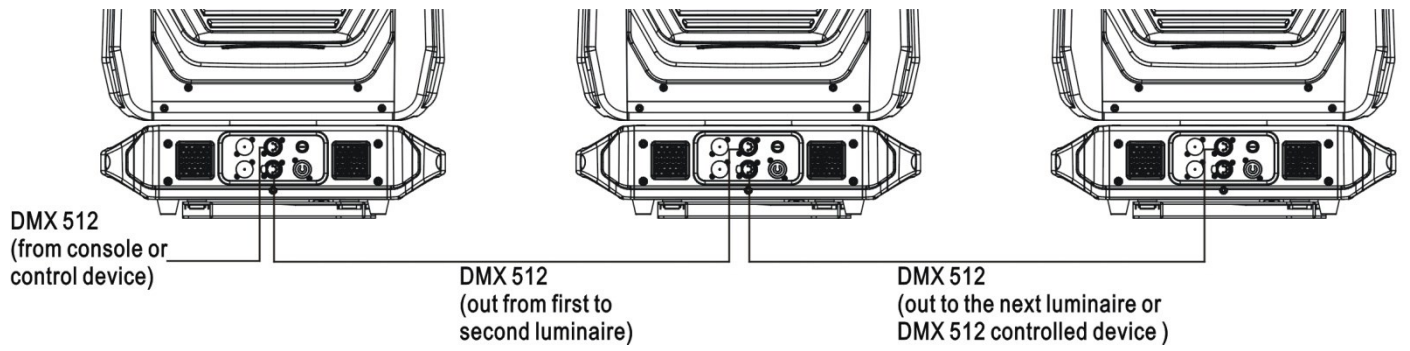

Figure 3: Data Link

Step 4. Connect AC Input Cable connector to power input source.

Step 5. Dress AC input and data cables and secure them so that they will not interfere with luminaire head and yoke movement.

Installation Procedures

Floor Mounting the Luminaire

All luminaires included in this manual are designed to sit directly on its base in a floor installation application. When used in this type of application, be sure to leave enough space around the luminaire to allow proper, uninterrupted airflow for cooling and movement.

Hanging the Luminaire

The VLZ PROFILE Luminaire can be hung horizontally or vertically from any structure designed to work with the type of load created by this moving luminaire. Two mounting truss hooks or other mounting hardware are required. Many compatible truss hooks are available from different manufacturers for your particular needs. A minimum of two hooks per luminaire is required. If mounting method does not use truss hooks, two attachment points, per luminaire, are required.

Install mounting hardware and brackets:

Step 1. Install truss hooks on two provided truss hook brackets as required as shown in **Figure 4**.

Step 2. Determine required configuration of bracket installation. Brackets may be installed in many different orientations as shown in **Figure 5**.

Step 3. While pulling up on locking mechanism release, fit keyed holes onto raised mounting buttons at bottom of enclosure. Slide forward and release locking mechanism to lock in place. Ensure brackets are locked securely.

WARNING: Ensure that the bracket locking mechanism is fully seated after the bracket is installed on the luminaire. **AVERTISSEMENT:** Assurez-vous que le mécanisme de support de verrouillage est complètement inséré après le support est installé sur l'appareil.

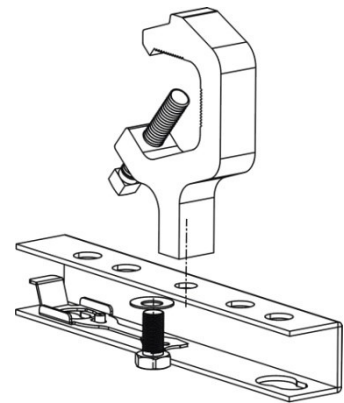

Figure 4: Truss Hook Installation

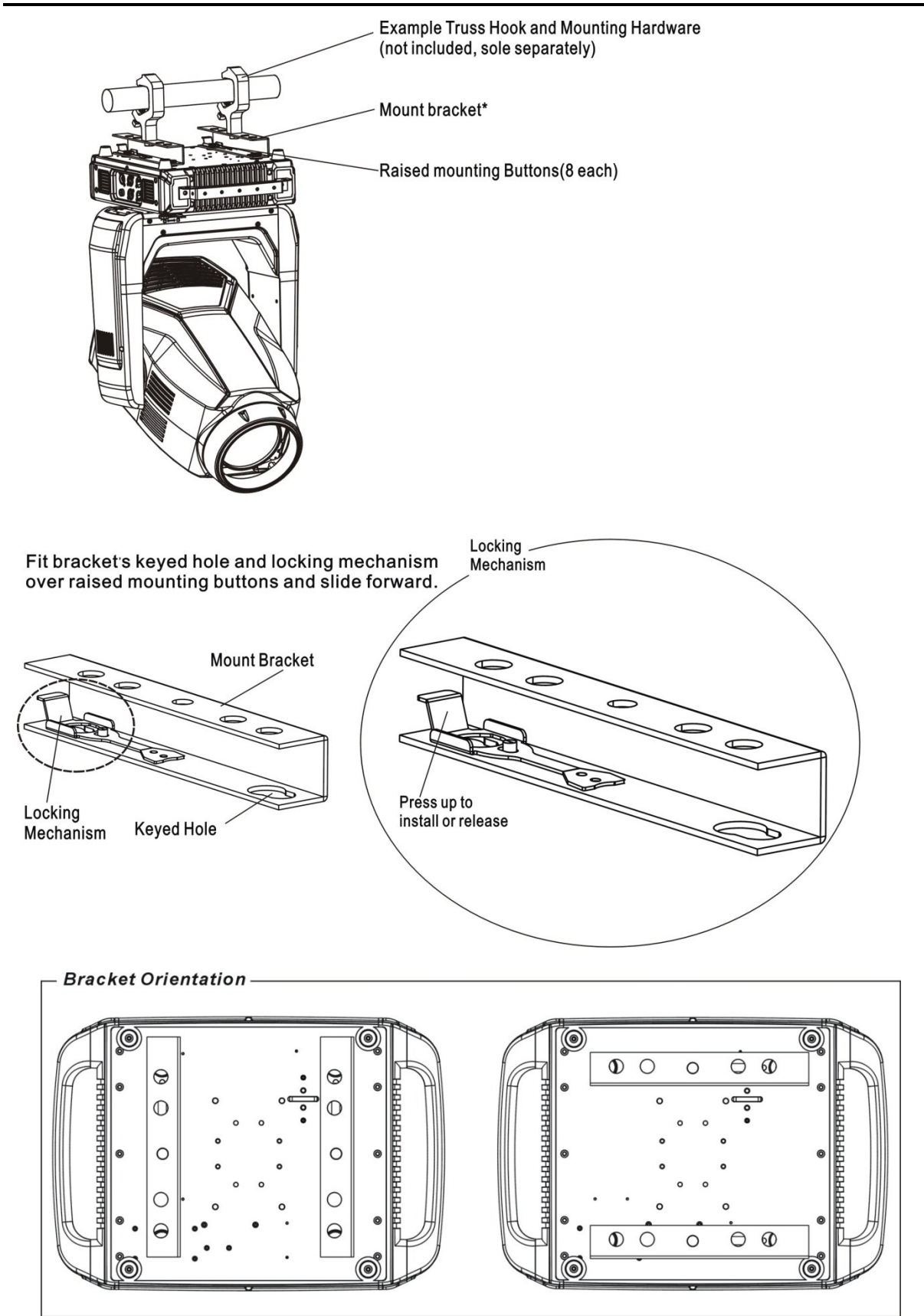

Figure 5: Installing Brackets on Luminaire Enclosure

Menu Operation





LCD Display and Menu System

The VLZ PROFILE Luminaire's LCD Display and Menu System provides local control for accessing the following fixture's settings:

- Address – to set the DMX address
- Configure – [various parameter settings](#)
- Fixture – fixture status, recalibrate, reboot, software version, view fixtures hours, crossload software, service, etc.
- DMX – [change the map mode, invert pan/tilt](#) , and check latest DMX data channel.
- Manual – manual control of parameters
- Test – test functions of parameters

The menu system is controlled at the Menu Display available at the enclosure input panel. If there are multiple luminaires in a system, any settings or changes would need to be made at each LCD Menu as desired.

Menu Controls

The menu system is controlled by an MODE/ESC, , and four Arrow (, , , ) buttons. These buttons function are shown in **Figure 6**.

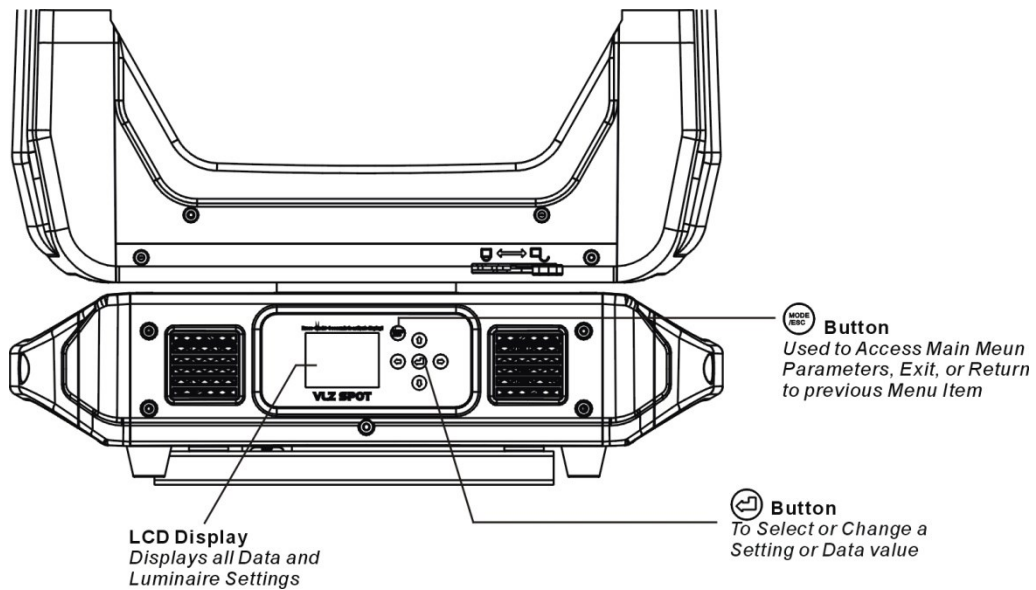

Figure 6: Menu Controls

LCD Display and Menu System Operation

The LCD Display Menu system consists of several categories. Use the Menu Buttons to access and make changes to the menu items. When the desired menu item is reached, press the desired Menu Button to display the menu options and to navigate and configure the menu options as required.

To navigate and access menu settings/selections:

Step 1. Make sure unit is powered and turned on.

Step 2. Press [MODE/ESC] to access menu categories.

Step 3. Use four Arrow (↑ ↓ ← →) buttons to navigate through the various options and settings.

Step 4. Once menu item is reached, press OK [Enter] to access the menu item parameters.

Step 5. Make changes to parameters as desired.

Step 6. Press (↵) button to accept changes.

Other LCD Display Features

LCD Menu Battery Operation

The LCD menu system utilizes a battery powered system for operation when the luminaire is not connected to power. The primary purpose of this mode is to allow basic setup and configuration of the luminaire.

To enable the battery operation of the menu system:

Step 1. Press [Mode] three seconds to activate display!

Step 2. Once enabled, the menu will function as normal with only the following sub-menu sections active:

- Address
- Configure
- DMX
- Fixture

Note: Any commands that require full power (calibrate, etc.) will be ignored while the menu system is in battery operation mode.

Step 3. To exit battery mode, press [MODE/ESC] three seconds.

Status Bar

The Status Bar (as illustrated in **Figure 7**) is present at all times and displays luminaire operational information of the luminaire. The Status Bar contains the following information:

- ERRORS –Displays a number indicating the total amount of current errors. When errors are present, messages will appear in Red text. When no errors are present, NO will display.
- **MODE**– Displays power mode of the fixture , STA- Standard Mode , STE-- Studio Mode
- MAP – Displays the current DMX map mode setting. 16E--16-bit Enh Mode;16—16 bit Mode
- ADDR – Displays the current DMX address for the fixture. NOTE, when the fixture does not detect a DMX input signal, the DMX address text will display in Red text.



Figure 7: LCD displayStatus Bar

Quick Reference DMX Map

DMX Channel	Parameter	Range DMX	Defaults	Description
1 2	Intensity High Byte Low Byte	0-65535	0	16-bit control of Fixture Intensity from 0 - 100%
3 4	Pan High Byte Low Byte	0 - 65535	32767	16-bit linear control of pan from 0°-540°. With <i>Expanded Movement</i> turned on, 630° of pan is possible
5 6	Tilt High Byte Low Byte	0 - 65535	32767	16-bit linear control of tilt from 0°-270°.
7 8	Edge High Byte Low Byte	0 - 65535	32767	16-bit linear control of edge functions
9 10	Zoom High Byte Low Byte	0 - 65535	32767	16-bit linear control of fixture zoom range between 0 (narrow) to 65535 (wide).
11	Programming Control	0 - 255 0 - 2 3 - 5 6 - 10 11 - 15 16 - 20 51 - 55 56 - 60	0 → → → → → → →	Used as a control channel for different programmable settings. Set value of desired effect. wait > 3 seconds, then set a desired value to 0 (Idle) Idle Linear Dimming Curve Square Law Dimming Curve TV Dimming Curve Architectural Dimming Curve Edge Track ON Edge Track OFF
12 13	Cyan High Byte Low Byte	0 - 65535	0	16 Bit control of cyan color mechanism.
14 15	Yellow High Byte Low Byte	0 - 65535	0	16 Bit control of yellow color mechanism.
16 17	Magenta High Byte Low Byte	0 - 65535	0	16 Bit control of Magenta color mechanism.
18 19	CTO High Byte Low Byte	0 - 65535	0	16 Bit control of CTO mechanism.

20	Color Wheel 1	0 - 255	0	8-bit linear control of Color Wheel 1. See Channel 16 for options.
		0 - 17	→	Open
		18 - 43	→	COLOR 1 - RED (Center at DMX 35)
		44 - 83	→	COLOR 2 - YELLOW (Center at DMX 71)
		84 - 118	→	COLOR 3 - KELLY GREEN (Center at DMX 107)
		119 - 155	→	COLOR 4 - MAGENTA (Center at DMX 143)
		156 - 192	→	COLOR 5 - AMBER (Center at DMX 179)
		193 - 225	→	COLOR 6 - CONGO BLUE (Center at DMX 215)
		226 - 255	→	OPEN END - NO COLOR

DMX Channel	Parameter	Range DMX	Defaults	Description
21	Color Wheel 1 Control	0 - 255	0	Used as a control channel for different movement options of Color Wheel 1.
		0 - 5	→	Linear Movement using shortest (quickest) path.
		6 - 10	→	Linear Movement using normal (longest) path.
		11 - 15	→	Wheel Spin Forward (Fast to Slow)
		16 - 20	→	Wheel Spin STOP
		21 - 25	→	Wheel Spin Reverse (Slow to Fast)
		26 - 56	→	Color Shake Quickest Path (Slow to Fast)
		57 - 87	→	Color Shake Normal Path (Slow to Fast)
		88 - 255	→	Reserved Values
22	Color Wheel 1 (Fixed Gobo Wheel)	0 - 255	0	8-bit linear control of Color Wheel 1. See Channel 23 for options.
		0 - 27	→	Open - No Gobo
		28 - 55	→	Gobo 1 - LEAFY BREAKUP
		56 - 83	→	Gobo 2 - MEDIUM CIRCLE
		84 - 111	→	Gobo 3 - LATTICE
		112 - 139	→	Gobo 4 - SWIRL
		140 - 167	→	Gobo 5 - RADIAL BREAKUP
		168 - 195	→	Gobo 6 - NEURONS
		196 - 223	→	Gobo 7 - GRID
224 - 255	→	Open End - No Gobo		
23	Color Wheel 1 Control	0 - 255	0	Used as a control channel for different movement options of Gobo Wheel 1.

		0 - 5	→	Linear Movement using shortest (quickest) path.
		6 - 10	→	Linear Movement using normal (longest) path.
		11 - 15	→	Wheel Spin Forward (Fast to Slow)
		16 - 20	→	Wheel Spin STOP
		21 - 25	→	Wheel Spin Reverse (Slow to Fast)
		26 - 56	→	Color Shake Quickest Path (Slow to Fast)
		57 - 87	→	Color Shake Normal Path (Slow to Fast)
		88 - 255	→	Reserved Values
24	Gobo Wheel 2 (Rotating Gobo Wheel)	0 - 255	0	8-bit control of Gobo Wheel 2. See Channel 27 for control options.
		0 - 5	→	Open - No Gobo
		6 - 10	→	Gobo 1 (Night Sky) Index
		11 - 15	→	Gobo 2 (Circle of Ovals) Index
		16 - 20	→	Gobo 3 (Bricked Out) Index
		21 - 25	→	Gobo 4 (Punch Card) Index
		26 - 30	→	Gobo 5 (Alpha Rays) Index
		31 - 35	→	Gobo 6 (HONEYCOMB) Index
		36 - 40	→	Gobo 7 (On the Rocks) Index
		41 - 45	→	Open - No Gobo
		46 - 50	→	Gobo 1 (Night Sky) Rotate
		51 - 55	→	Gobo 2 (Circle of Ovals) Rotate
		56 - 60	→	Gobo 3 (Bricked Out) Rotate
		61 - 65	→	Gobo 4 (Punch Card) Rotate
		66 - 70	→	Gobo 5 (Alpha Rays) Rotate
		71 - 75	→	Gobo 6 (HONEYCOMB) Rotate
		76 - 80	→	Gobo 7 (On the Rocks) Rotate
				Gobo Wheel 2 Continued on Next Page

DMX Channel	Parameter	Range DMX	Defaults	Description
24	Gobo Wheel 2 Continued from previous page			
		81 - 85	→	Open - No Gobo
		86 - 90	→	Gobo 1 (Night Sky) Rotate with Mega Stepping
		91 - 95	→	Gobo 2 (Circle of Ovals) Rotate with Mega Stepping
		96 - 100	→	Gobo 3 (Bricked Out) Rotate with Mega Stepping

		101 - 105 106 - 110 111 - 115 116 - 120 121 - 255	→ → → → →	Gobo 4 (Punch Card) Rotate with Mega Stepping Gobo 5 (Alpha Rays) Rotate with Mega Stepping Gobo 6 (HONEYCOMB) Rotate with Mega Stepping Gobo 7 (On the Rocks) Rotate with Mega Stepping Reserved Values
25 26	Gobo 2 Rot/Index High Byte Low Byte	0 - 65535 0 - 126 127 - 128 129 - 255	32767 → → →	16-bit control of index and rotation of gobo wheel 1. Rotate Fast to Slow <<<< Rotation STOP Rotate Slow to Fast >>>>
27	Gobo Wheel 2 Control	0 - 255 0 - 5 6 - 10 11 - 20 21 - 50 51 - 60 61 - 90 91 - 120 121 - 150 151 - 180 181 - 210 211 - 255	0 → → → → → → → → → → →	Used as a control channel for different movement options for Gobo Wheel 1 (Channel 24). Gobo Selection using shortest (quickest) path. Gobo Selection using normal (longest) path. Reserved Values Wheel Spin Forward (Fast to Slow) Wheel Spin STOP Wheel Spin Reverse (Slow to Fast) Gobo Shake Quickest Path (Slow to Fast) Gobo Shake Normal Path (Slow to Fast) Gobo Twist Quickest Path (Slow to Fast) Gobo Twist Normal Path (Slow to Fast) Reserved Values
28	Animation 1	0 - 255 0 - 126 127 - 255	0 → →	Inserts animation wheel into beam. Animation Wheel OUT Animation Wheel IN
29 30	Animation 1 Rot/Index High Byte Low Byte	0 - 65535 0 - 126 127 - 128 129 - 255	32767 → → →	16-bit control of index and rotation of Animation Wheel 1. Rotate Fast to Slow <<<< Rotation STOP Rotate Slow to Fast >>>>
31	Animation 1 Control	0 - 255 0 - 5 6 - 10 11 - 15 16 - 20 21 - 25 26 - 56	0 → → → → → →	Used as a control channel for Animation Wheel 1. Index using shortest (quickest) path. Index using normal (longest) path. Rotate Normal Rotate with Mega Stepping Reserved Values Image Shake using shortest (quickest) path slow to fast.

		57 - 87 88 - 255	→ →	Image Shake using normal (longest) path slow to fast. Reserved Values
32	Iris	0 - 255	0	Controls Iris mechanism from open (DMX 0) to Full (DMX 255).

DMX Channel	Parameter	Range DMX	Defaults	Description
33 34	Frame 1A High Byte Low Byte	0 - 65535	0	16 Bit Control of Framing Shutter 1A from Open (DMX 0) to Full (DMX 65535).
35 36	Frame 1B High Byte Low Byte	0 - 65535	0	Controls Framing Shutter 1B from Open (DMX 0) to Full (DMX 255).
37 38	Frame 2A High Byte Low Byte	0 - 65535	0	Controls Framing Shutter 2A from Open (DMX 0) to Full (DMX 255).
39 40	Frame 2B High Byte Low Byte	0 - 65535	0	Controls Framing Shutter 2B from Open (DMX 0) to Full (DMX 255).
41 42	Frame 3A High Byte Low Byte	0 - 65535	0	Controls Framing Shutter 3A from Open (DMX 0) to Full (DMX 255).
43 44	Frame 3B High Byte Low Byte	0 - 65535	0	Controls Framing Shutter 3B from Open (DMX 0) to Full (DMX 255).
45 46	Frame 4A High Byte Low Byte	0 - 65535	0	Controls Framing Shutter 4A from Open (DMX 0) to Full (DMX 255).
47 48	Frame 4B High Byte Low Byte	0 - 65535	0	Controls Framing Shutter 4B from Open (DMX 0) to Full (DMX 255).
49 50	Frame Rotate High Byte Low Byte	0 - 65535	32767	Controls Framing Shutter mechanism from +/- 90°

51	Prism	0 - 255	0	Controls Prism mechanism with following values.
		0 - 5	→	Open
		6 - 10	→	Index
		11 - 15	→	Rotate Normal
		16 - 20	→	Rotate with Mega Stepping
		21 - 255	→	Reserved Values
52	Prism Index/Rot High Byte	0 - 65535	32767	16-bit control of prism rotation and index.
53	Low Byte	0 - 126	→	Rotate Fast to Slow <<<<
		127 - 128	→	Rotation STOP
		129 - 255	→	Rotate Slow to Fast >>>>
54	Frost	0 - 255	0	Insert control of frost mechanism with the following values.
		0 - 50	→	Open - No Frost or Diffusion
		51 - 100	→	Insert Light Diffusion
		101 - 150	→	Insert Heavy Frost
		151 - 200	→	Insert both Light Diffusion and Heavy Frost

DMX Channel	Parameter	Range DMX	Defaults	Description
55	Strobe	0 - 255	0	Controls Strobe functionality.
		0 - 3	→	Open
		4 - 6	→	Closed
		7 - 32	→	Normal Strobe - Slow to Fast
		33 - 58	→	Random Strobe - Slow to Fast
		59 - 84	→	Random Sync - Slow to Fast
		85 - 110	→	Pulse > - Slow to Fast
		111 - 136	→	Pulse > Random - Slow to Fast
		137 - 162	→	Pulse > Random Sync - Slow to Fast
		163 - 188	→	Pulse < - Slow to Fast
		189 - 214	→	Pulse < Random - Slow to Fast
		215 - 240	→	Pulse < Random Sync - Slow to Fast
56	Focus Timing	0 - 255	255	Adjustment of fixture timing to control Pan/Tilt mechanisms. - See Timing Channel Chart in User Manual
57	Optics Timing	0 - 255	255	Adjustment of fixture timing to control lensing mechanisms. - See Timing Channel Chart in User Manual
58	Color Timing	0 - 255	255	Adjustment of fixture timing to control color mechanisms. - See Timing Channel Chart in User Manual

59	Beam Timing	0 - 255	255	Adjustment of fixture timing to control beam shaping mechanisms. - See Timing Channel Chart in User Manual
60	Gobo Timing	0 - 255	255	Adjustment of fixture timing to control gobo mechanisms. - See Timing Channel Chart in User Manual
61	Luminaire Control	0 - 255	0	Control Channel used for full fixture settings, lamp controls, and miscellaneous modes. Set descreet value of desired effect, wait >3 seconds, then set value to 0 (Idle).
		0 - 5	→	Idle (Default)
		6 - 10	→	Full Luminaire ReCal - Also Used to Wake fixture up from shutdown
		11 - 15	→	Reserved Values
		16 - 20	→	Reserved Values
		21 - 25	→	Fixture Shutdown
		26 - 30	→	Display - Menu ON
		31 - 35	→	Display - Menu OFF
		36 - 40	→	ReCal Position
		41 - 45	→	ReCal Color
		46 - 50	→	ReCal Gobo
		51 - 55	→	ReCal Beam
		56 - 60	→	ReCal Optics
		61 - 65	→	ReCal Dimmer/Strobe
		66 - 70	→	Reset Fixture to Defaults - See Manual for a list of factory defaults.
		71 - 75	→	Full Luminaire Reboot. This command will reset all processors in fixture, then ReCal all parameters.
		76 - 80	→	Fixture Status On/Off. This command will enable the display to show fixture status for 5 min. After this time, displays will return to default configuration. Repeating this command in less than 5 minutes will behave as a toggle.
		81 - 85	→	Standard Mode - Fixture operates at maximum output (Default)
		86 - 90	→	Studio Mode - Reduced output with lower fan settings
		91 - 255	→	Reserved Values

PHILIPS
VARI***LITE**

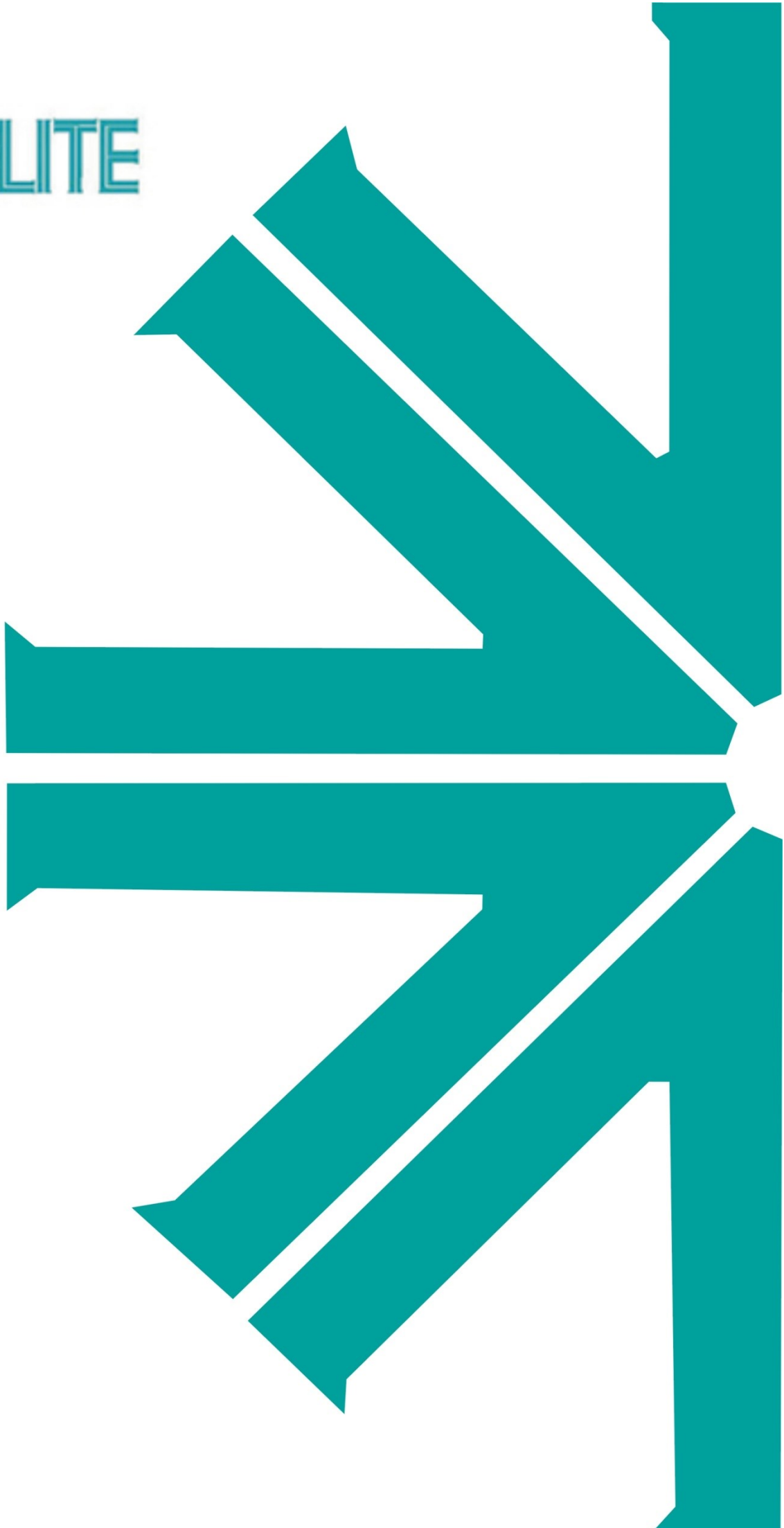

Philips Vari-Lite

10911 Petal Street

Dallas, Texas 75238

1.877.VARILITE

1.214.647.7880