

PHILIPS

VARILITE***

VL3015LT Spot Luminaires



USER'S MANUAL

All other brand or product names which may be mentioned in this manual are trademarks or registered trademarks of their respective companies or organizations.

The information furnished in this manual is for informational use only and is subject to change without notice. Please check www.vari-lite.com for latest version. Philips Vari-Lite assumes no responsibility or liability for any errors or inaccuracies that may appear in this manual. All information and graphics are property of Philips Vari-Lite, a Philips group company, 10911 Petal Street Dallas, Texas 75238 USA.

Version as of: **26 August 2013**

Part number: **02.9698.0002 A**

VL3015LT Spot Luminaire User's Manual

©2013 Philips Vari-Lite, a Philips group company. All Rights Reserved.

How To Obtain Warranty Service

A copy of the Philips Vari-Lite Limited Warranty was included in the shipping package for this VARI*LITE product.

To obtain warranty service, please contact customer service at 1-877-VARI-LITE (1-877-827-4548), +1-214-647-7880, or entertainment.service@philips.com and request a Return Material Authorization (RMA) for warranty service. You will need to provide the model and serial number of the item being returned, a description of the problem or failure and the name of the registered user or organization. If available, you should have your sales invoice to establish the date of sale as the beginning of the warranty period.

Once you obtain the RMA, pack the unit in a secure shipping container or in its original packing box. Be sure to clearly indicate the RMA number on all packing lists, correspondence, and shipping labels. If available, please include a copy of your invoice (as proof of purchase) in the shipping container. With the RMA number written legibly on or near the shipping address label, return the unit, freight prepaid, to:

Philips Vari-Lite
Attention: Warranty Service (RMA# _____)
10911 Petal Street
Dallas, Texas 75238 USA
Attention: Warranty Service

As stated in the warranty, it is required that the shipment be insured and FOB our service center.



IMPORTANT! When returning products to Philips Vari-Lite for repairs (warranty or out-of-warranty) from a country other than the USA, “*Philips Lighting Controls Division*”, must appear in the address block as the Importer of Record (IOR) on all shipping documentation, Commercial Invoices, etc. This must be done in order to clear customs in a timely manner and prevent returns.

Compliance Notice

FCC This equipment has been tested and found to comply with the limits for a Class A digital device pursuant to Part 15 of FCC Rules. These limits are designed to provide reasonable protection against harmful interference when this equipment is operated in a commercial environment. This equipment generates, uses, and can radiate radio frequency energy and, if not installed and used in accordance with Philips Vari-Lite system, service, and safety guidelines, may cause harmful interference to radio communications. Operation of this equipment in a residential area is likely to cause harmful interference, in which case the user will be required to correct the interference at his/her own expense.



Declaration of Conformity

We declare, under our sole responsibility, that this product complies with the relevant clauses of the following standards and harmonized documents:

Safety

EN 60598-2 17:1984+A1:1987+A2:1990 used in conjunction with EN 60598-1:2008 /A11:2009

EMC

EN 55022:2010

EN 55024:2010

RoHS

EN 50581:2012

We certify that the product conforms to the protection requirements of council directives: Low Voltage Directive 2006/95/EC, 2004/108/EC (EMC), and Restriction of the use of certain Hazardous Substances in electrical and electronic equipment Directive (RoHS), 2011/65/EC. Equipment referred to in this declaration of conformity was first manufactured in 2012 in compliance with these standards.

Safety Notice

It is extremely important to read ALL safety information and instructions provided in this manual and any accompanying documentation before installing and operating the products described herein. Heed all cautions and warnings during installation and use of this product.

Safety symbols used throughout this manual are as follows:



CAUTION advising of potential damage to product.



WARNING advising of potential injury or death to persons.

GENERAL INFORMATION PERTAINING TO PROTECTION AGAINST ELECTRICAL SHOCK, FIRE, EXPOSURE TO EXCESSIVE UV RADIATION, AND INJURY TO PERSONS CAN BE FOUND BELOW.

WARNING:

INSTRUCTIONS FOR CONTINUED PROTECTION AGAINST FIRE

1. VARI*LITE luminaires have been designed for use with specific lamp types. The VL3015LT Spot Luminaire requires an 1500 Watt Short Arc Lamp. Installing another type of lamp may be hazardous.
2. Luminaires may be mounted on any type of surface as long as mounting instructions are followed. See instructions detailed in this manual.
3. Note distance requirement from combustible materials or illuminated objects for VARI*LITE luminaires.

WARNING:

INSTRUCTIONS FOR CONTINUED PROTECTION AGAINST ELECTRICAL SHOCK

1. VARI*LITE luminaires are designed for dry locations only. Exposure to rain or moisture may damage luminaire.
2. Disconnect power before servicing any VARI*LITE equipment.
3. Servicing to be performed by qualified personnel only.

WARNING:

INSTRUCTIONS FOR CONTINUED PROTECTION AGAINST EXCESSIVE EXPOSURE TO UV RADIATION

1. Many VARI*LITE luminaires use a lamp that produces UV radiation. DO NOT look directly at lamp.
2. It is hazardous to operate luminaires without lens or shield. Shields, lenses, or ultraviolet screens shall be changed if they have become visibly damaged to such an extent that their effectiveness is impaired. For example, by cracks or deep scratches.

WARNING:

INSTRUCTIONS FOR PROTECTION AGAINST INJURY TO PERSONS

1. Exterior surfaces of the luminaire will be hot during operation. Use appropriate safety equipment (gloves, eye protection, etc.) when handling and adjusting hot equipment and components.
2. Luminaires will have a hot lamp when operating. Disconnect power and allow lamp to cool before replacing.
3. Arc lamps emit ultraviolet radiation which can cause serious skin burn and eye inflammation. Additionally, arc lamps operate under high pressure at very high temperatures. Should the lamp break, there can exist a danger of personal injury and/or fire from broken lamp particles being discharged.
4. Wear eye protection when relamping.
5. Appropriate safety equipment (gloves, eye protection) should be used when handling damaged lamps.
6. If lamp is touched with bare hands, clean lamp with denatured alcohol and wipe with lint-free cloth before installing or powering up the luminaire.
7. The lamp shall be changed if it has become damaged or thermally deformed.

WARNING:

RF INTERFERENCE

1. This is a Class A product. In a domestic environment this product may cause radio interference, in which case, the user may be required to take adequate measures.

ARC LAMP CHARACTERISTIC CONSIDERATIONS

1. Arc lamps require a period of time to relight after a power interruption or a severe voltage dip. In some cases, lamp will automatically relight after it has cooled depending on Lamp Power-Up State configuration setting.
2. Burning position is Universal.

Sicherheitshinweise

Es ist äußerst wichtig, ALLE Sicherheitsinformationen und -hinweise in diesem Handbuch und dem beiliegenden Informationsmaterial zu lesen, bevor Sie die hierin beschriebenen Produkte installieren bzw. bedienen. Halten Sie bei der Installation und dem Einsatz dieses Produkts alle Warnhinweise und Vorsichtsmaßnahmen ein.

Folgende Sicherheitssymbole werden in diesem Handbuch verwendet:



VORSICHT - weist auf möglichen Produktschaden hin.



WARNUNG - weist auf mögliche Körperverletzung und Lebensbedrohung hin.

NACHSTEHEND FINDEN SIE ALLGEMEINE HINWEISE ÜBER SICHERHEITSVORKEHRUNGEN GEGEN ELEKTROSCHOCK, FEUER, ÜBERHÖHTE UV-STRAHLUNG UND KÖRPERVERLETZUNGEN.

WARNUNG:

HINWEISE ZUM FEUERSCHUTZ

1. VARI*LITE -Scheinwerfer sind ausschließlich für den Einsatz mit bestimmten Lampentyps. Achten Sie auf den Lampentyp (1500 Watt Short Arc Lamp), bevor Sie die jeweiligen Lampen ersetzen. Die Installation eines anderen Lampentyps kann gefährlich sein.
2. Scheinwerfer können auf jeder beliebigen Oberfläche montiert werden, solange Sie die Montageanweisungen befolgen. Detaillierte Hinweise finden Sie in diesem Handbuch.
3. Beachten Sie die Einhaltung des erforderlichen Sicherheitsabstandes der VARI*LITE -Scheinwerfer von brennbarem Material oder beleuchteten Objekten.

WARNUNG:

HINWEISE ZUM SCHUTZ GEGEN ELEKTROSCHOCK

1. VARI*LITE -Scheinwerfer eignen sich ausschließlich für trockene Standorte. Regen oder Feuchtigkeit können die Scheinwerfer beschädigen.
2. Unterbrechen Sie die Stromzufuhr, bevor Sie mit der Arbeit an VARI*LITE -Geräten beginnen.
3. Die Geräte sollten nur von qualifiziertem Personal gewartet werden.

WARNUNG:

HINWEISE ZUM SCHUTZ GEGEN ÜBERHÖHTE UV-STRAHLUNG

1. Viele VARI*LITE -Scheinwerfer verwenden die Lampentyp, der UV-Strahlen abgibt. **SCHAUEN SIE NICHT** direkt in die Lampe.
2. Es ist gefährlich, Leuchten ohne Linsen oder Blenden zu bedienen. Blenden, Linsen oder Ultraviolettscirme müssen ausgetauscht werden, sofern deren Schutzwirkung durch sichtbare Beschädigung (z. B. Sprünge oder Schrammen) eingeschränkt ist.

WARNUNG:

HINWEISE ZUM SCHUTZ GEGEN KÖRPERVERLETZUNGEN

1. Bei Betrieb sind die Außenflächen der Scheinwerfer heiß. Verwenden Sie bei der Bedienung von aufgeheizter Apparatur die jeweils geeignete Sicherheitsausrüstung (Handschuhe, Augenschutz etc.).
2. Bei Betrieb der Scheinwerfer ist die Lampe heiß. Unterbrechen Sie die Stromzufuhr und lassen Sie die Lampe abkühlen, wenn Sie diese austauschen.
3. Bogenlampen senden ultraviolette Strahlen aus, die Hautverbrennungen und Augenentzündungen verursachen können. Der Betrieb von Bogenlampen erfolgt unter Hochdruck und bei hohen Temperaturen. Sollte die Lampe zerbrechen, besteht die Gefahr von Körperverletzung bzw. von Feuer, das von Lampenteilen ausgelöst werden kann.
4. Tragen Sie beim Austausch der Lampen einen Augenschutz.
5. Die geeignete Sicherheitsausrüstung (Handschuhe, Augenschutz) sollte beim Umgang mit beschädigten Lampen verwendet werden.
6. Wenn die Lampe mit bloßen Händen berührt wird, reinigen Sie sie mit denaturiertem Alkohol und einem flusenfreien Tuch, bevor Sie die Scheinwerfer installieren oder in Betrieb nehmen.
7. Wenn die Lampe beschädigt oder durch Hitzeeinwirkung deformiert ist, muß diese ausgetauscht werden.

WARNUNG:

HF-INTERFERENZ

1. Es handelt sich um ein Produkt der Klasse A. In einer Wohnumgebung kann das Produkt Hochfrequenzstörungen verursachen. In diesem Fall müssen eventuell geeignete Maßnahmen getroffen werden.

BESONDERHEITEN VON BOGENLAMPEN

1. Bogenlampen benötigen eine gewisse Zeitdauer, um nach einem Stromausfall oder einem Spannungsgefälle wieder aufzuleuchten. In einigen Fällen wird die Lampe nach Abkühlung automatisch wieder aufleuchten, je nach der Systemkonfigurationseinstellung des Lampeneinschaltungsstatus.
2. Die Brennposition ist Universal.

Notes de sécurité

Avant de procéder à l'installation des produits décrits dans ce guide et de les mettre en marche, il est extrêmement important de lire TOUS les renseignements et TOUTES les directives de sécurité contenues dans ce guide ainsi que toute documentation jointe. Tenir compte de tous les avertissements et suivre toutes les précautions pendant l'installation et l'utilisation de cet appareil.

Les symboles de sécurité utilisés dans ce guide sont les suivants :



ATTENTION Ce symbole annonce que l'appareil risque d'être endommagé.



AVERTISSEMENT Ce symbole annonce qu'il y a risque d'accident grave ou même fatal.

CETTE SECTION CONTIENT DES INFORMATIONS GÉNÉRALES POUR SE PROTÉGER CONTRE LES DÉCHARGES ÉLECTRIQUES, LES INCENDIES, L'EXPOSITION EXCESSIVE AUX RAYONS UV ET TOUT AUTRE ACCIDENT POUVANT ENTRAÎNER DES BLESSURES.

AVERTISSEMENT:

DIRECTIVES POUR SE PROTÉGER CONTRE LES INCENDIES

1. Les luminaires VARI*LITE ont été conçus pour être utilisés uniquement avec certaines type de lampes. Vérifier le type de lampe (1500 Watt Short Arc Lamp) avant de remplacer les lampes. L'installation d'un autre type de lampe peut poser un danger.
2. Les luminaires peuvent être fixés sur tout type de surface tant que les directives de montage sont respectées. Voir les explications détaillées dans ce guide.
3. Vérifier la distance à respecter entre les matériaux combustibles ou les objets illuminés et les luminaires VARI*LITE .

AVERTISSEMENT:

DIRECTIVES POUR SE PROTÉGER CONTRE LES DÉCHARGES ÉLECTRIQUES

1. Les luminaires VARI*LITE sont conçus pour une utilisation au sec uniquement. Une exposition à la pluie et à l'humidité risque d'endommager le luminaire.
2. Débrancher l'appareil avant de procéder à la révision de tout matériel VARI*LITE .
3. Les révisions doivent être effectuées uniquement par des personnes qualifiées.

AVERTISSEMENT:

DIRECTIVES POUR SE PROTÉGER CONTRE UNE EXPOSITION EXCESSIVE AUX RAYONS UV

1. Plusieurs luminaires VARI*LITE utilisent une lampe qui produit des rayons UV. NE PAS fixer son regard sur la lampe.
2. L'utilisation des luminaires sans lentille ou blindage pose des risques. Tous blindages, lentilles ou écrans ultraviolet visiblement endommagés au point que leur efficacité en est affectée doivent être remplacés, par exemple s'il y a des fissures ou de profondes rayures.

AVERTISSEMENT:

DIRECTIVES POUR SE PROTÉGER CONTRE LES ACCIDENTS POUVANT ENTRAÎNER DES BLESSURES

1. Les surfaces externes du luminaire deviennent brûlantes quand l'appareil est en marche. Pour manœuvrer ou ajuster des appareils brûlants et leurs composants, se protéger suffisamment (gants, protection pour les yeux, etc.).
2. La lampe du luminaire est brûlante lorsqu'il est en marche. Débrancher le courant et attendre que la lampe ait refroidi avant de la remplacer.
3. Les lampes à arc émettent des rayons ultraviolets pouvant causer de graves brûlures sur la peau et une inflammation des yeux. De plus, les lampes à arc fonctionnent sous haute tension à de très hautes températures. Si la lampe se casse, les particules de la lampe cassée peuvent causer blessures et/ou incendie en s'éparpillant.
4. Se protéger les yeux pour remplacer la lampe.
5. Utiliser des appareils de protection appropriés (gants, protection des yeux) pour manier des lampes endommagées.
6. Si la lampe a été touchée avec des mains nues, la nettoyer avec de l'alcool dénaturé et l'essuyer avec un chiffon non-pelucheux avant d'installer ou de brancher le luminaire.
7. Si la lampe a été endommagée ou a reçu une déformation thermique, elle doit être remplacée.

AVERTISSEMENT:

INTERFÉRENCE RF

1. Cet appareil est de Classe A. Dans un environnement domestique, cet appareil peut causer des interférences radio, et si c'est le cas, l'utilisateur peut avoir à prendre des mesures adéquates.

CONSIDÉRATIONS DES CARACTÉRISTIQUES DE LAMPES À ARC

1. Après une interruption de courant ou une baisse importante de voltage, les lampes à arc mettent du temps avant de se rallumer. Dans certains cas, la lampe se rallumera automatiquement après s'être refroidie. Cela dépend de la manière dont le système est réglé pour le statut de mise en marche de la lampe.
2. La position Brûler est Universelle.

Aviso sobre Seguridad

Es muy importante leer TODA la información e instrucciones sobre seguridad que se indica en este manual así como en los documentos adjuntos antes de instalar y operar los productos descritos. Se debe prestar atención a todos los avisos y advertencias durante la instalación y uso de este producto.

Los símbolos de seguridad usados en este manual son los siguientes:



CUIDADO, indica posibles daños al producto.



ADVERTENCIA, indica posibles lesiones o muerte a las personas.

LA INFORMACIÓN GENERAL RELACIONADA A LA PROTECCIÓN CONTRAGOLPES DE CORRIENTE ELÉCTRICA, INCENDIO, EXPOSICIÓN EXCESIVA A RADIACIÓN ULTRA VIOLETA Y LESIONES A LAS PERSONAS SE PUEDE ENCONTRAR SEGUIDAMENTE:

ADVERTENCIA:

INSTRUCCIONES PARA PROTECCIÓN CONTINUA CONTRA INCENDIO

1. Las luminarias VARI*LITE han sido diseñadas para ser usadas solamente con algunas lámparas. Tome nota del tipo de lámpara (1500 Watt Short Arc Lamp) antes de reemplazarla. Instalación de otro tipo de lámpara puede ser peligroso.
2. Las luminarias se pueden instalar en cualquier tipo de superficie siempre que se sigan las instrucciones de instalación. Vea las instrucciones detalladas en este manual.
3. Tome nota de los requerimientos de distancia de materiales combustibles u objetos iluminados para las luminarias VARI*LITE .

ADVERTENCIA:

INSTRUCCIONES PARA PROTECCIÓN CONTINUA CONTRA CHOQUE ELÉCTRICO

1. Las luminarias VARI*LITE están diseñadas solamente para lugares secos. La exposición a la lluvia o humedad pueden dañar la luminaria.
2. Desconecte la energía antes de dar servicio a cualquier equipo de VARI*LITE .
3. El servicio debe ser realizado solamente por personal calificado.

ADVERTENCIA:

INSTRUCCIONES PARA PROTECCIÓN CONTINUA CONTRA LA EXPOSICIÓN EXCESIVA DE RADIACIÓN ULTRA VIOLETA

1. Muchas luminarias VARI*LITE usan un tipo de lámpara que produce radiación UV. NO mire directamente a la lámpara.
2. Es peligroso operar luminarias sin lentes o protectores. Debe cambiar los protectores, lentes o pantallas ultravioletas si se aprecia que han sido dañadas, y que su efectividad pudiera estar deteriorada. Por ejemplo, si tuvieran rajaduras o raspaduras profundas.

ADVERTENCIA:

INSTRUCCIONES PARA PROTECCIÓN CONTRA LESIONES DE PERSONAS

1. Las superficies exteriores de las luminarias están calientes durante su operación. Use un equipo de seguridad apropiado (guantes, protección para los ojos, etc.) cuando haga ajustes en el equipo y componentes que están calientes.
2. Cuando las luminarias están en operación la lámpara estará muy caliente. Desconecte la energía y deje que la lámpara se enfríe antes de reemplazarla.
3. Las lámparas de arco emiten radiaciones ultravioletas que pueden ocasionar serias quemaduras a la piel e inflamación a los ojos. Además, las lámparas de arco operan a alta presión y muy alta temperatura. Si la lámpara se rompe, puede existir el peligro de lesiones al personal o un incendio ocasionado por las partículas de la lámpara rota que se caen.
4. Use protección para los ojos cuando vuelve a colocar una lámpara nueva.
5. Use un equipo de seguridad apropiado (guantes, protección para los ojos, etc.) cuando trabaje con lámparas dañadas.
6. Si toca la lámpara con las manos, limpie la lámpara con alcohol desnaturalizado y con tela sin pelusas antes de instalar o volver a conectar la luminaria.
7. Cambie la lámpara si está dañada o deformada termicamente.

ADVERTENCIA:

INTERFERENCIA RF

1. Este es un producto de Clase A. En el ambiente de la casa este producto puede ocasionar radiointerferencia, en cuyo caso, el usuario debe tomar las medidas adecuadas.

CONSIDERACIONES SOBRE LAS CARACTERÍSTICAS DE LA LÁMPARA DE ARCO

1. Las lámparas de arco requieren un período de tiempo para volver a iluminarse después de una interrupción de energía o de una severa caída de voltaje. En algunos casos, la lámpara se volverá a iluminar en forma automática después que se ha enfriado dependiendo de la configuración del sistema de energía de la lámpara.
2. La posición de encendido es universal.

安全性に関する注意事項

ここに記載されている製品を取り扱う場合は、まず本マニュアルおよび付属のマニュアルの安全性に関する情報と説明をすべてお読みください。また、実際に本製品を取り付けたり使用する際には、すべての注意事項および警告に留意して作業してください。

本マニュアルでは、以下の安全マークを使用しています。



注意：製品に損傷を与える危険性があります。



警告：人身事故につながる危険性があります。

感電、火災、UV放射に対する過度の露出、および人身事故を防ぐための一般的な情報については、以下の説明をお読みください。

警告：

火災の発生を防ぐためのヒント

1. VARI*LITE® 照明器具は、ランプを使用するように設計されています。ランプを交換する際は、ランプの種類（など）を確認するようにしてください。他の種類のランプを取り付けると危険です。
2. 照明器具は、本マニュアルの指示に従って操作するかぎり、どのようなタイプの表面にでも取り付けることができます。詳細については、本マニュアルを参照してください。
3. ヒューズを交換する場合は、同じヒューズ（同じ種類、同じクラス）を使用してください。
4. VARI*LITE® 照明器具は、可燃性物質または他の光源から必要な距離だけ離して配置してください。

警告：

感電を防ぐためのヒント

1. VARI*LITE® 照明器具は、乾燥した環境で使用するよう設計されています。雨で濡れる場所や湿気の多い場所に取り付けると、照明器具が傷むことがあります。
2. VARI*LITE® 照明器具を修理点検する場合は、必ず先に電源を切ってください。
3. 照明器具の修理点検は、資格を持つ技師のみが行うようにしてください。

警告：

過度の UV 放射にさらされないためのヒント

1. VARI*LITE® 照明器具の多くは、UV 放射を生ずる HID タイプのランプを使用しています。ランプを直視することは避けてください。
2. レンズまたはシールドを使わずに照明器具を点灯すると危険です。レンズ、シールド、紫外線画面は、ひび割れや深い引っかき傷などにより、その効力が損なわれるようになったら取り替えるようにします。

警告：

人身事故を防ぐためのヒント

1. 照明器具が点灯しているときは、その外側が熱くなります。熱くなった器具やコンポーネントを取り扱う際には、適切な防具（手袋や保護用眼鏡）を使用してください。
2. 照明器具が点灯しているときは、そのランプが熱くなります。ランプを交換する場合は、照明器具の電源を切り、ランプの温度が下がるまで待ってください。ランプの裏ぶたをあけると、遮断スイッチが働いて、ランプの電源が切れる場合があります。
3. アーク灯は紫外線を放射します。この紫外線によって、ひどい火傷を負ったり、目の炎症を起こすことがあります。さらに、アーク灯は、高圧高温の状態ですべて光を放射します。そのため、万一アーク灯が破損すると、飛び散った破片で人身事故や火災が発生する危険性があります。
4. 再点灯するときには、保護用眼鏡を着用してください。
5. 損傷したランプを取り扱う場合は、適切な防具（手袋や保護用眼鏡）を着用してください。
6. 手袋を着用せずに直接手でランプを触った場合は、変性アルコールを使ってランプをきれいにし、糸くずの出ない布で拭いてから照明器具を取り付け、電源を入れるようにします。
7. 傷がついたランプや熱によって変形したランプは取り替えてください。

警告：

RF 干渉

1. 本製品は Class A に分類されます。本製品は、家庭環境において無線干渉を起こす可能性があります。その場合、使用者は適切な処置を取らなければならないことがあります。

アーク灯の特性

1. 停電後または大きな電圧ディップ後にアーク灯を再点灯する場合は、しばらく時間をおくようにしてください。Lamp Power-Up State) システム設定によっては、温度が下がったときに自動的に再点灯される場合もあります。
2. アーク灯は点光源です。

Introduction

About This Manual 1
 Additional Documentation..... 1
 Text Conventions 2
 Customer Service..... 2

Chapter 1. Description

Features

VL3015LT Spot Standard Features 4

Components

Included Items 5
 Replacement Items/Accessories 6
 Luminaire Overview 7

Chapter 2. Installation

Special Warnings

Exceptional Safety Information for the VL3015LT Spot Luminaire 10

Power and Data Cabling Requirements

Power 11
 Data Cables 13
 Recommended Cable Types/Manufacturers 14
 DMX Termination Connector 14

Installation Procedures

Hanging the Luminaire 15
 Floor Mounting the Luminaire 18
 Connecting Data and Power 18

Powering Up

Power Up and Configuration Procedure..... 19

Addressing

Program Starting Address 20
 Program Starting Address Without Calibrating Luminaire 20

Chapter 3. Operation

VL3015LT Spot DMX Channels

VL3015LT Spot Channel Mapping 22
 VL3015LT Spot Control Channel Functions..... 26

VL3015LT Spot DMX Mapping

VL3015LT Spot Color Control..... 27
 Color Mixing..... 27
 Fixed Color Wheel 1 27
 Fixed Color Wheel 2 28
 Fixed Color Wheels DMX Map..... 29
 VL3015LT Spot Beam Control..... 29
 Strobe 29
 Range..... 30
 VL3015LT Spot Gobo/Effects Control..... 30

VARI*LITE VL3015LT SPOT LUMINAIRE USER'S MANUAL

Overview of Gobos and Gags used in VL3015LT Spot Luminaire..... 30
Gobo / Gag Use and Positioning 30
Gobo Wheels 1, 2, and 3 31
Index and Rotation 33

VL3015LT Spot Luminaire Timing
VL3015LT Spot Timing Channel Information 35

Updating Software
USB Download and Programming 43
Transferring Software From Luminaire to Luminaire 44

Chapter 4. Menu System

Menu Operation
What Is the Menu System? 48
Controls Operation..... 48
 Default State..... 49
 Shortcuts..... 49

Menu Functions
VL3015LT Spot Menu System Overview 50
VL3015LT Spot Menu System Function Chart..... 51
Menu Function Definitions..... 54

Self-Tests
Running Parameter Tests 56

Appendix A. Luminaire Care and Routine Maintenance

Equipment Handling
Locations/Use 60
Lamps 60
 Servicing 60
 Heat 60
 Lamp Life..... 60
Solid State Electronics 61
 Electrostatic Discharge (ESD) 61
 Printed Circuit Boards (PCBs)..... 61

Troubleshooting
Error Messages 62
Troubleshooting Guide 63

Routine Maintenance
Lamp Replacement 64
Align Lamp..... 65
Gobo Replacement - Gobo Wheels 66
Fixed Color Filter Replacement..... 69
Cleaning Optics, Filters and Gobos 71
Followspot Handle Accessory Installation (Optional) 72

Appendix B. Technical Specifications
VL3015LT Spot Luminaire 75

Introduction

About This Manual

This manual provides necessary information regarding safety, installation, operation and routine maintenance for Philips VARI*LITE VL3015LT Spot Luminaires. Familiarizing yourself with this information will help you to get the most out of your luminaire.



WARNING: It is important to read ALL accompanying safety and installation instructions to avoid damage to the product and potential injury to yourself or others.

This manual covers the following models:

Model	Part Number	Source
VL3015LT Spot Luminaire	20.9698.0001	1500 Watt Short Arc Lamp (<i>Triple wattage, double-ended lamp. The lamp is capable of operation at 900W, 1200W or 1650W - mode selectable from fixture or console</i>)

Additional Documentation

A service manual, only for Authorized Philips VARI*LITE Service Centers and technicians, of the VL3015LT Spot Luminaire is available in electronic (PDF) format:

- Luminaire Service Manual (02.9698.0010)
- Testing, Troubleshooting, Component Replacement and Illustrated Parts Breakdown.

Note: Performing maintenance procedures may void the product warranty. Refer to the Philips Vari-Lite Limited Warranty card included in the product shipping package for more information.

- For more information on installing DMX512 control systems, the following publication is available for purchase from the United States Institute for Theatre Technology (USITT), "Recommended Practice for DMX512: A Guide for Users and Installers, 2nd edition" (ISBN: 9780955703522). USITT Contact Information:

USITT Inc.
 315 South Crouse Avenue Suite 200
 Syracuse, NY 13210
 Tel: 800-938-7488 or +1-315-463-6463
 Fax: 866-398-7488 or +1-315-463-6525
www.usitt.org

Text Conventions

The following styles and meanings are used throughout this manual:

Style	Meaning
[Button]	Front panel button. Example: Press [Menu].
[Up] / [Down] arrows	Press either [Up] or [Down] arrow button at Menu Display.
MENU	LCD Menu Display read-out. Example: Press [Up] / [Down] arrows until LAMP appears.

Customer Service

Our Goal

At Philips Vari-Lite, we are committed to providing you the highest quality in customer service. Our comprehensive resources are available to help your business succeed and ensure you get the full benefit of being a Philips Vari-Lite customer. Whether your needs are telephone troubleshooting assistance, product training or technical service, our full-time staff of experienced professionals is on-hand to provide support.

How to Reach Us

For assistance in your area, call the dealer from which your product was purchased.

or

Contact an Authorized VARI*LITE Service Center.

or

Contact the Philips Vari-Lite Customer Service Department, 9am -6pm CST Monday through Friday, at the following:

phone: 1-877-VARI-LITE (1-877-827-4548) or +1-214-647-7880

email: entertainment.service@philips.com

Additional Resources

For additional resources and documentation, please visit our website at www.vari-lite.com and follow the Support link.

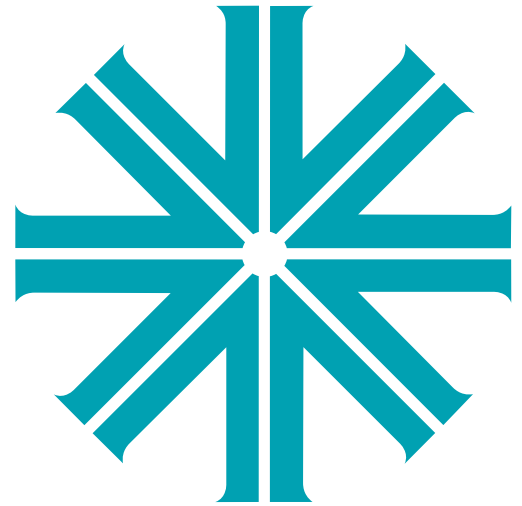

CHAPTER 1.

Description

This chapter contains descriptions of luminaire features and components, along with a list of accessories which are available.

- **Features**
- **Components**

Features



VL3015LT Spot Standard Features

The VL3015LT Spot Luminaire has the following standard features:

- 10:1 zoom optics system with 6° to 60° range.
- CMY color mixing system.
- Two fixed color wheels with five interchangeable color filters each capable of continuous wheel rotation for additional effects.
- Variable CTO color temperature correction wheel.
- Mechanical iris provides continuous beam size control.
- Three gobo/effects wheels combine to each offer four rotatable, indexable gobo positions and one open position.
- Independent, drop-in armature that rotates with 3-facet prism.
- Independent, drop-in armature that contains variable frost.
- Full-field dimming system.
- Dual blade strobe system.
- Repositional pan/tilt system.
- Control by DMX512 protocol.
- Fan cooled.
- UV/IR glass.
- 1500W short arc lamp source.

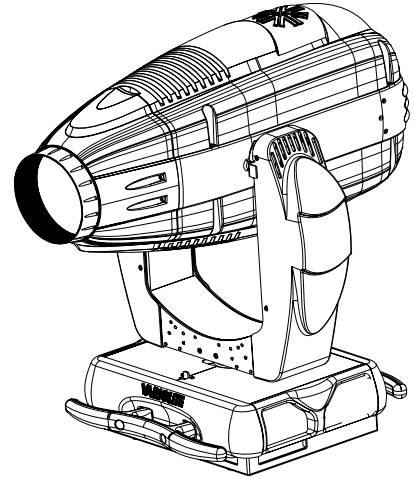

Note: For more information and product specifications, refer to [“Technical Specifications” on page 75.](#)



Components

Included Items

The following illustration shows all items included with the luminaire:

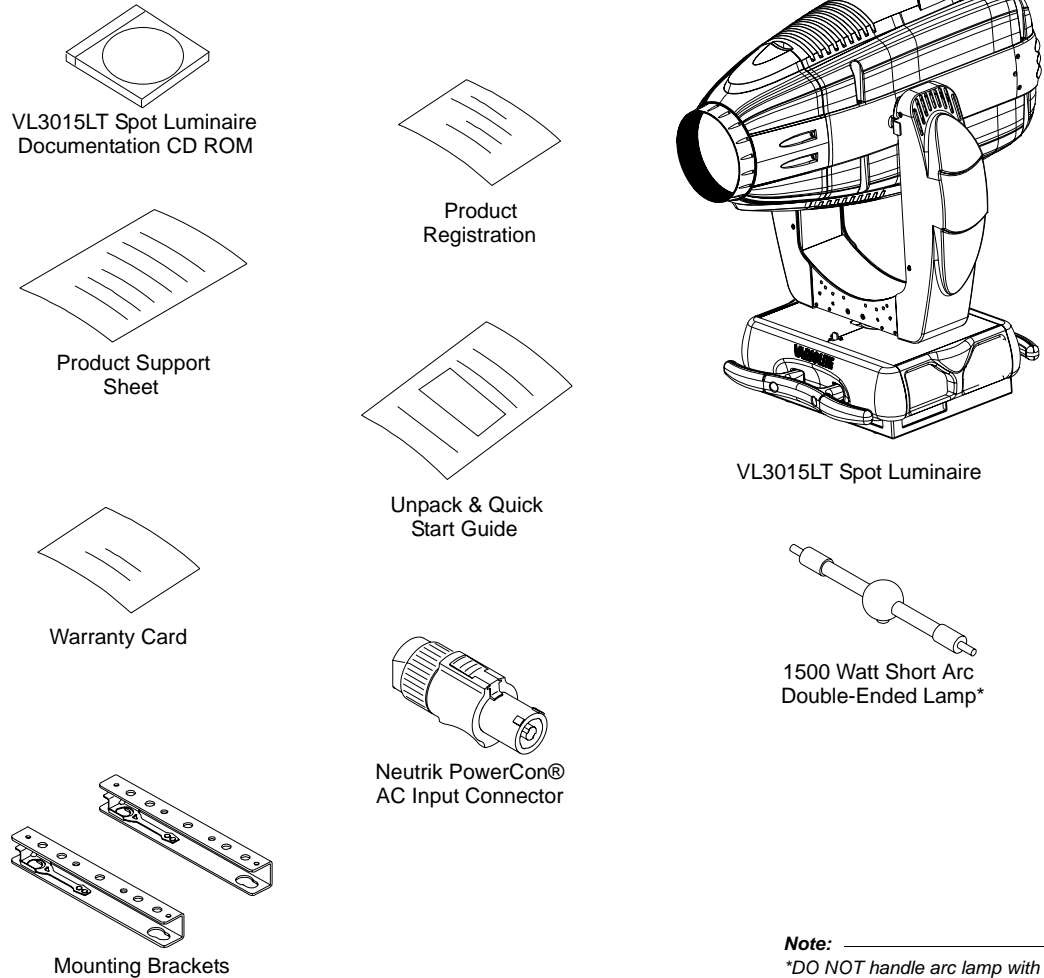

Note:

**DO NOT handle arc lamp with bare hands. Wear cotton gloves. Keep lamp dirt and grease free.*

Figure 1-1: Included Items

Replacement Items/Accessories

The following optional and/or replacement items can be ordered directly from your Authorized Philips Vari-Lite Dealer. (Please order by Philips Vari-Lite part number.)

Philips Vari-Lite Part Number	Accessory Description
22.9620.0194	Safety Cable Assembly
21.9698.9610	VL3015LT Spot Followspot Handle (1 each)
25.9661.0057	DMX Termination Connector Assembly
28.8500.0054	USB Luminaire Programming Kit
55.6840.0001	Truss Hook, Mega-Clamp, Round and Square
55.6841.0001	Truss Hook, Mega-Claw for 2" Round Tube
71.9686.1502	1500 Watt Short Arc Lamp
PC1BE	AC Input Cable, PowerCon with Bare End (no connector), 1 Meter
PC1GTL208	AC Input Cable, PowerCon with L6-20 Twist Lock (Male), 1 Meter

Luminaire Overview

The following illustration shows the external luminaire components and controls.

Upper Enclosure Assembly
Houses power supply, ballast, and display board.

Mounting Brackets
Note: Truss hooks, clamps, etc. are sold separately.

Backcap Assembly
Provides access to lamp for replacement and provides controls for beam adjustment.

Input Panel
Provides DMX In and Thru, and AC Power connections. (see detail below)

Yoke Assembly
Houses Master Control Board (MCB).

Head Assembly
Houses CMY color, gobo, strobe, prism, frost, zoom lens and iris mechanisms.

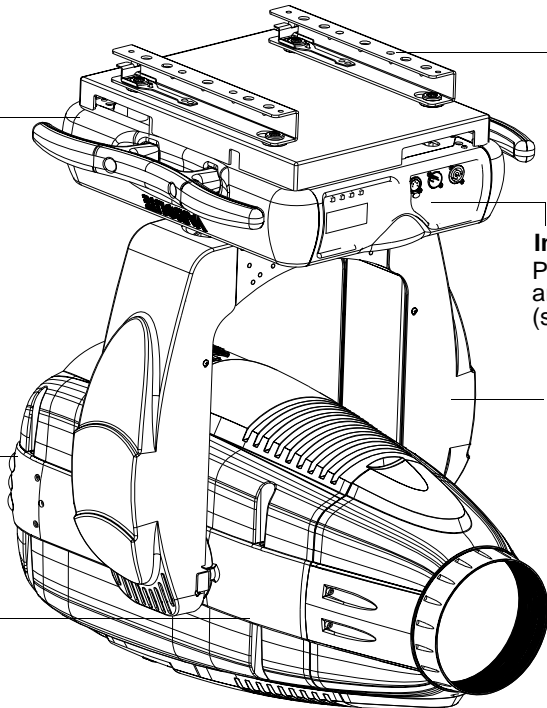

Input Panel Components

Product Label ID

Menu Display
Used to input manual commands, program, test, set defaults and access internal status information.

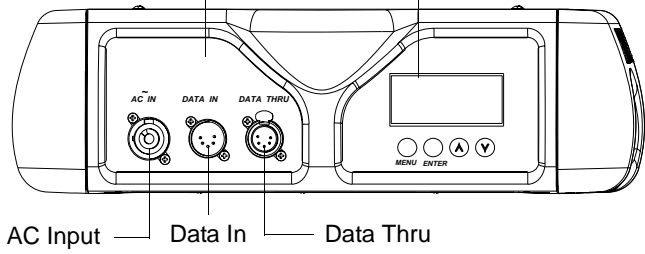

Beam Adjustment Controls

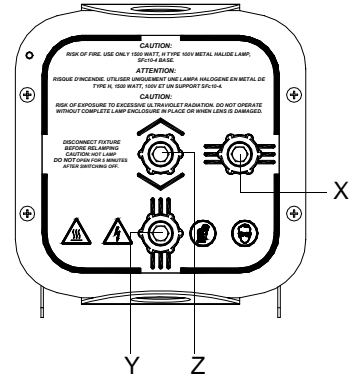
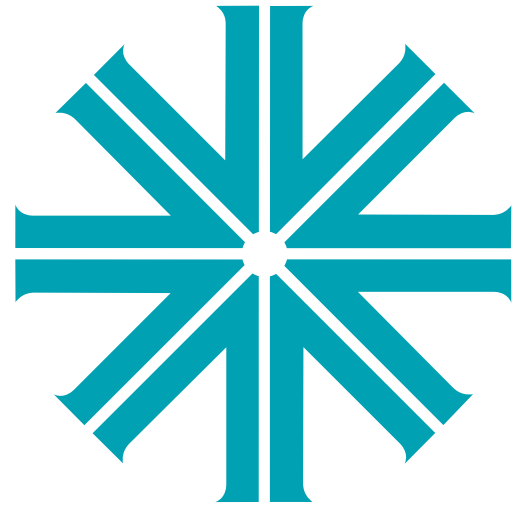

Figure 1-2: External Components and Controls

Notes



CHAPTER 2.

Installation

This chapter contains instructions for installation of the luminaire. It includes connecting power and data, along with instructions for powering up the luminaire for the first time and addressing it within your system.

- **Special Warnings**
- **Power and Data Cabling Requirements**
- **Installation Procedures**
- **Powering Up**
- **Addressing**

Special Warnings

Exceptional Safety Information for the VL3015LT Spot Luminaire

The light intensity and power density of the VL3015LT Spot Luminaire exceeds that of other fixtures typically used in this application. The warnings and cautions that follow are critically important to the safe operation of this fixture. *This product is for commercial use only by trained professionals only.*

If you have any questions about the safe installation and operation of the VL3015LT Spot Luminaire, please contact Vari-Lite customer service at 1-877-VARI-LITE (1-877-827-4548), +1-214-647-7880, or entertainment.service@philips.com.



WARNING: *Light Beam Projects Intense Heat.* Do not illuminate objects within 4.0 m (13.2 feet) of the VL3015LT Spot Luminaire. Objects within this range can scorch, melt, or ignite from the heat projected by the light beam.



WARNING: *High Intensity Light Output.* Do not look directly into the light beam. Avoid looking at nearby surfaces illuminated by the beam. It is hazardous to operate luminaires without lens or shield. Shields, lenses, or ultraviolet screens must be changed if they have become visibly damaged to such an extent that their effectiveness is impaired. For example, by cracks, deep scratches, or coating breakdown.



WARNING: *Hot Exterior Surfaces.* The exterior surfaces of the luminaire can get very hot - up to 195°C (383°F). Do not touch any surface of the luminaire while it is operating. Keep all combustible materials a minimum of 200 mm (8 inches) away from the luminaire. To maintain cooling fan operation after the lamp is doused, keep the luminaire powered on for 5 minutes. Wait an additional 5 minutes before touching the luminaire.



WARNING: *Operating Environment.* Do not operate the luminaire when the ambient temperature exceeds 40°C (104°F). Do not attempt to bypass thermostatic switches.



WARNING: *Approved Lamp Type.* Use only approved lamp types in VL3015LT Spot Luminaire. The following lamps are approved for use: Osram SharXS® HTI® 1500 W/D7/60 metal halide lamp (shipped with units), Philips / MSR 1510 Gold™ SA/DE Lamp, or GE CSR 1500/S/DE/60 96800 Lamp. Installing any other lamp types can be hazardous. Dispose of used lamps properly. Users can check the latest version of Vari-Lite Technical Notice TN-248, on the Vari-Lite web site, for all approved lamps.

Power and Data Cabling Requirements

Power

The luminaire requires standard AC power distribution from 200-240 VAC, 50/60 Hz. Current required is up to 12 Amps depending on the AC supply voltage and product model.



Note: The mating Neutrik PowerCon connector is supplied, however, you will need to purchase or construct a cable appropriate for your application.

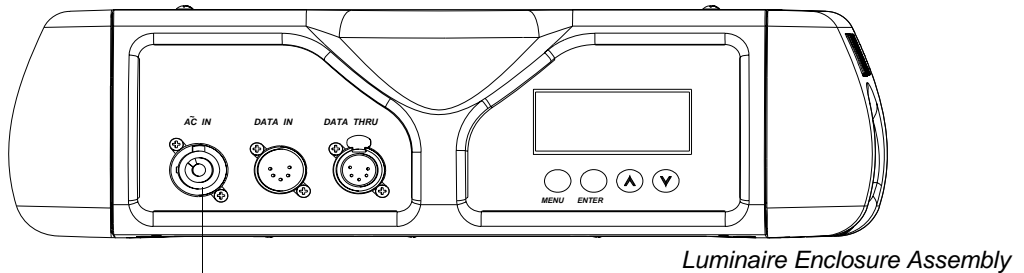

AC Power Input
 3-Pole Neutrik PowerCon
 Locking Connector for AC
 Input Power

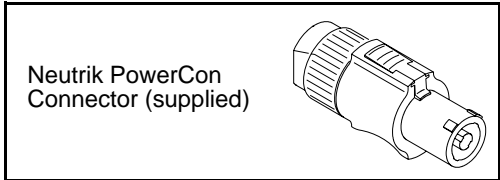

Figure 2-1: Power Connector

Depending on the application, the luminaire’s AC input cable may require a different connector. If required, install a new connector meeting your requirements using the following wire color code reference:

Wire*	Connection
Green/Yellow	AC Ground
Blue	AC Neutral
Brown	AC Line

* International (Harmonized) Standard



WARNING: DO NOT connect to three-phase Delta service in countries with 240 volt power.

Note: The lamp will not strike below 180 volts RMS.

VARI*LITE VL3015LT SPOT LUMINAIRE USER'S MANUAL

For single-phase power at 200-240 volts RMS:

Connection	Pin
AC Neutral	X
AC Line	Y
Ground (Earth)	G

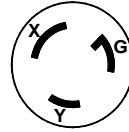

For three-phase power at 208 volts RMS:

Connection	Pin
Phase 1	X
Phase 2	Y
Ground (Earth)	G

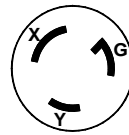

WARNING: It is not recommended to power any VARI*LITE luminaire from a dimmer - even in 'NONDIM' mode. Dimmer and non-dim modules are not suitable sources of power because their output modifies the AC wave form. This may work for a short time, but will eventually result in power problems, luminaire mis-operation and/or failure and may void the luminaire's warranty.

Data Cables

The VL3015LT Spot Luminaire is equipped with two, 5-pin XLR connectors for DATA IN and DATA THRU (out) applications. DATA IN requires a 5-pin, female XLR connector and DATA THRU requires a 5-pin, male XLR connector. When purchasing or constructing data cables, it is important that not only the correct cable type be used, but also quality cable to ensure a reliable DMX512 system. Your cabling should meet the following USITT DMX specification requirements:

- Suitable for use with EIA485 (RS485) operation at 250k baud.
- Characteristic impedance 85-150 ohms, nominally 120 ohms.
- Low capacitance.
- Two twisted pairs.
- Foil and braid shielded.
- 24 AWG minimum gauge for runs up to 1000 feet (300m).
- 22 AWG minimum gauge for runs up to 1640 feet (500m).

Note: Microphone type cables and other general purpose, two-core audio or signal cables are not suitable for use with DMX512.

The XLR 5-pin connectors should be wired as follows:

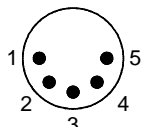
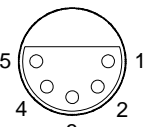
Pin/Wire Code to XLR Connectors						
Data Thru Cable Pinout	Pin 1	Pin 2	Pin 3	Pin 4	Pin 5	Data In Cable Pinout
 Male Conn	Foil & Braided Shield	1st conductor of 1st twisted pair	2nd conductor of 1st twisted pair	1st conductor of 2nd twisted pair	2nd conductor of 2nd twisted pair	 Female Conn
		Data (-)	Data (+)	Data (-)	Data (+)	

Note: Refer to the USITT Recommended Practice for DMX512 guide for additional information regarding DMX512 systems. How to obtain a copy is detailed in [“Additional Documentation” on page 1.](#)

Recommended Cable Types/Manufacturers

These are only a few of the suitable cable types. Any quality EIA485, twisted pair, 120 ohm, shielded cable will also work.

Table 2-1: Recommended Cable Types

Type	Pairs	ZΩ*	Jacket	AWG	Use	Temp (F)
Belden Cables						
1215A	2	150	PVC	26	IBM Type 6 Office cable	75
1269A	2	100	PTFE	22 (Solid)	High Temp, Plenum cable	200
8102	2	100	PVC	24	UL2919	80
8132	2	120	PVC	28	UL2919	80
8162	2	100	PVC	24	UL2493	60
82729	2	100	PTFE	24	High Temp, Plenum cable	200
88102	2	100	PTFE	24	High Temp, Plenum cable	200
89696	2	100	PTFE	22	High Temp, Plenum cable	200
89729	2	100	PTFE	24	High Temp, Plenum cable	200
89855	2	100	PTFE	22	High Temp, Plenum cable	200
9729	2	100	PVC	24	UL2493	60
9804	2	100	PVC	28	UL2960	60
9829	2	100	PVC	24	UL2919	80
9842	2	120	PVC	24	UL2919	80
Proplex Cables						
PC224P	2	110	Polyurethane	22	Heavy Duty and Portable	105
PC224T	2	110	PVC	22	UL2464	105
PC226T	3	110	PVC	22	UL2464	

* Characteristic Impedance

DMX Termination Connector

A DMX termination connector is required at the last luminaire (or "far end of the line") to prevent signal reflections. Signal reflections may cancel out the signal at certain line lengths, resulting in errors. The terminator is also necessary for software downloads and running tests on multiple luminaires. To construct your own connector, you will need the following components:

- 5-pin, male XLR connector.
- Two 1/4W 5% 120 ohm resistors.

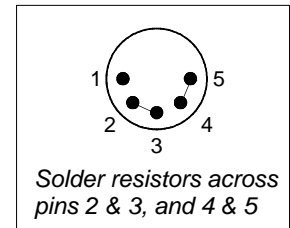

Note: A DMX termination connector assembly is available as an accessory from Philips Vari-Lite. See ["Replacement Items/Accessories"](#) on page 6.

Installation Procedures

Hanging the Luminaire

The VL3015LT Spot Luminaire can be hung horizontally or vertically from any structure designed to work with the type of load created by this moving luminaire. Two mounting bracket assemblies (provided) are used to attach truss hooks or other mounting hardware as required. Many compatible truss hooks are available from different manufacturers for your particular needs.

A minimum of one hook per truss hook bracket is required. If mounting method does not use truss hooks, two attachment points per truss hook bracket are required. When attaching more than one point on a single bracket, the attach points must be spaced as far apart as possible using the supplied mounting holes.

Install mounting hardware and brackets:

Step 1. Install truss hooks on two provided truss hook brackets as required.

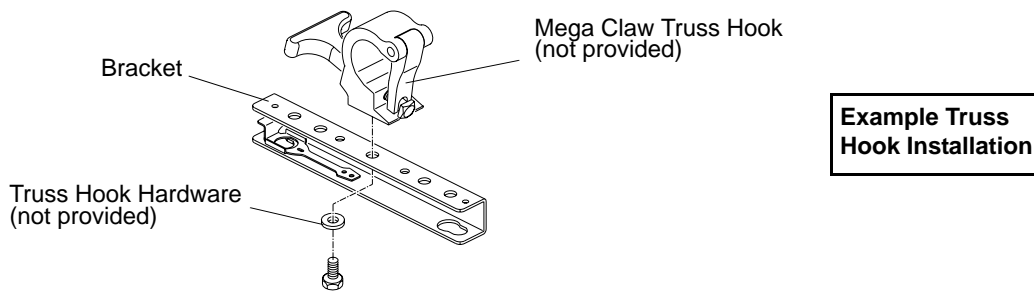

Figure 2-2: Installing Truss Hooks

Note: Various types of truss hooks can be used. The Mega Claw truss hook (as shown in the example above) as well as many other standard hooks, can be ordered separately.

Step 2. Determine required configuration of bracket installation. Brackets may be installed in either orientation as shown. The brackets must be parallel (as illustrated).

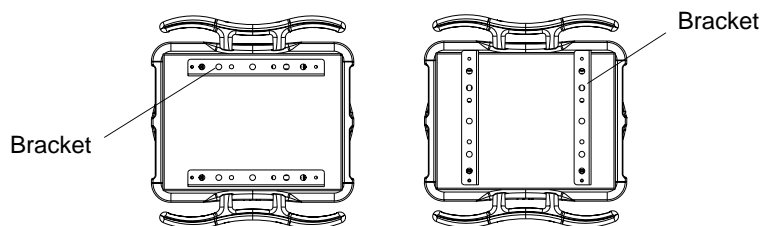

Figure 2-3: Bracket Orientation Options

Step 3. While pulling up on locking mechanism release, fit keyed holes onto raised mounting buttons at bottom of enclosure. Slide forward and release locking mechanism to lock in place. Ensure brackets are locked securely. (Always face brackets in same direction as shown.)



WARNING: Ensure that the bracket locking mechanism is fully seated after the bracket is installed on the luminaire.

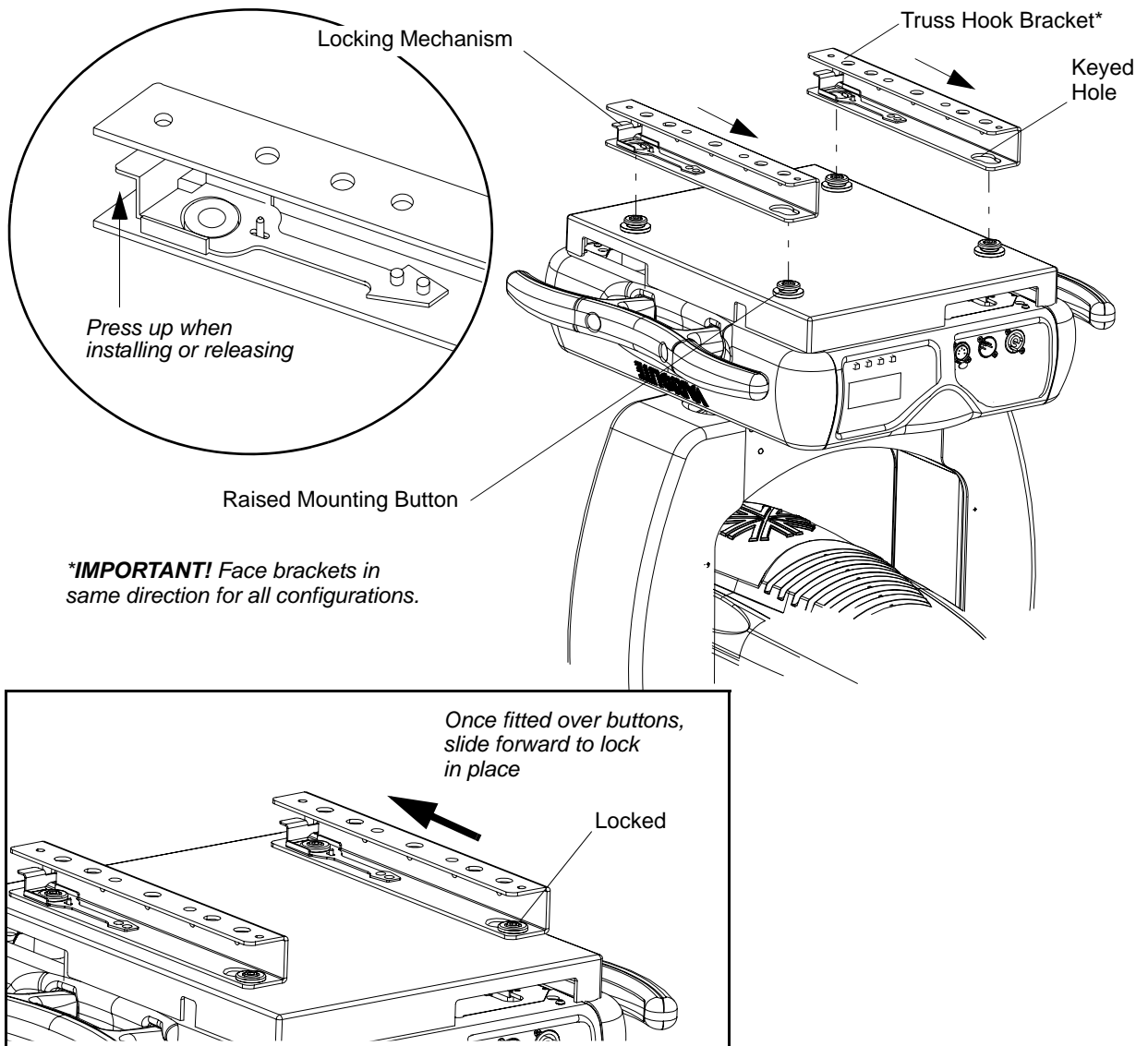

Figure 2-4: Installing Brackets on Luminaire Enclosure

Installing in Truss:

- Step 1. Using two people, lift luminaire into mounting position.
- Step 2. Secure in place with truss hook. Ensure truss hook hardware that locks hook in place (e.g. wing bolt) is properly tightened and that luminaire is fully supported.
- Step 3. Attach safety cable (as required) as follows:
 - a. Connect one end of cable to luminaire handle.
 - b. Loop at least once around truss/pipe and attach other end of cable to other handle.
- Step 4. Make sure service tilt and pan locks are disengaged so luminaire moves freely.
- Step 5. Connect power and data cables according to procedure given in [“Connecting Data and Power” on page 18.](#)

SAFETY CABLE: Recommended for all hanging installation and may be required by national and local codes. Use enclosure handles for safety cable anchor points for this fixture.

NOTE: The enclosure handles were tested and are in compliance (for safety cable anchor points) of the following safety standards: IEC / EN 60598-2-17.6.6 and UL1573.

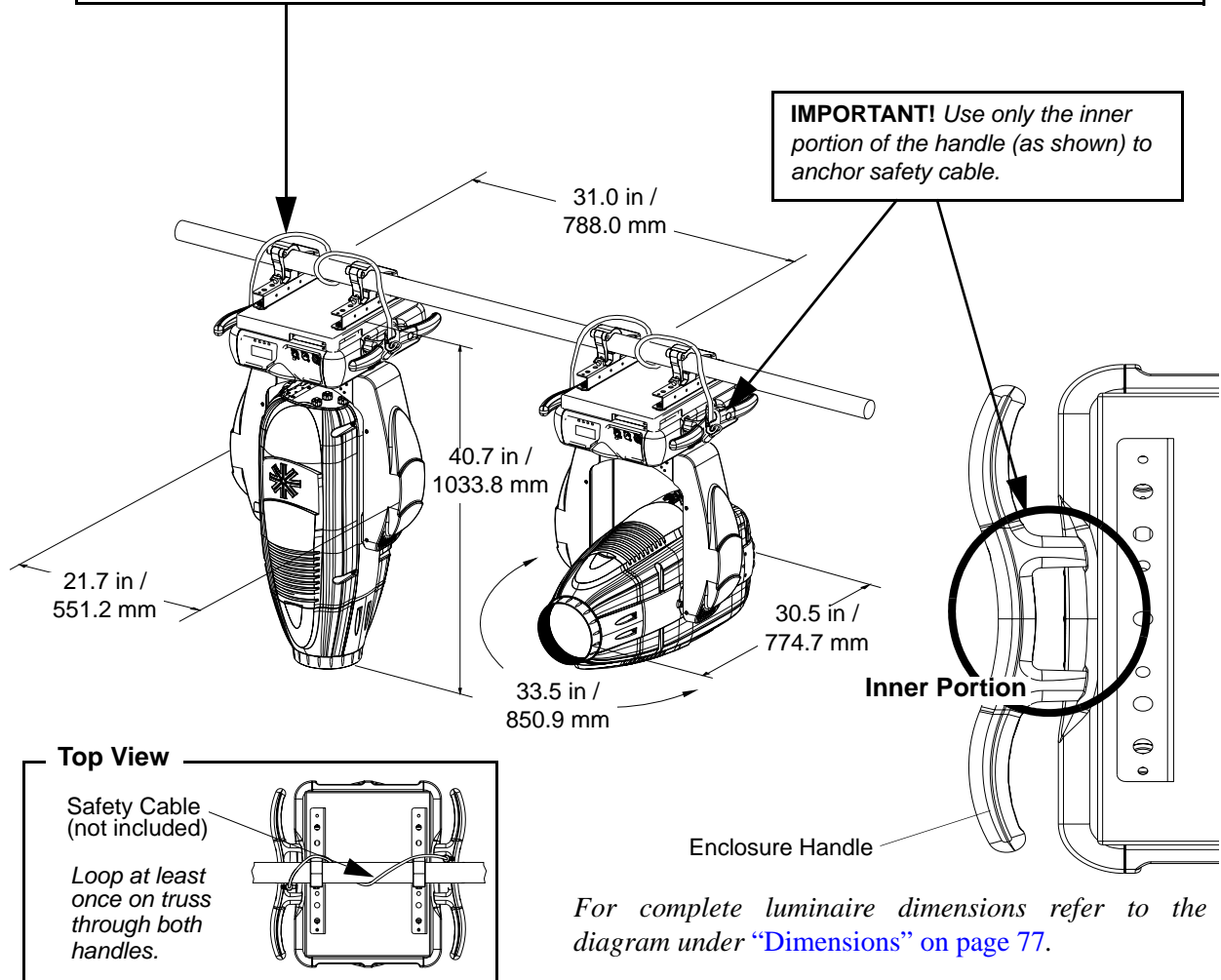

Figure 2-5: Hanging Configuration and Dimensions

Floor Mounting the Luminaire

The luminaire enclosure is sufficient to stabilize the luminaire in a floor installation, provided that the mounting surface is flat and sturdy.



WARNING: Light Beam Projects Intense Heat. Do not illuminate objects within 4.0 m (13.2 feet) of the VL3015LT Spot Luminaire. Objects within this range can scorch, melt, or ignite from the heat projected by the light beam.

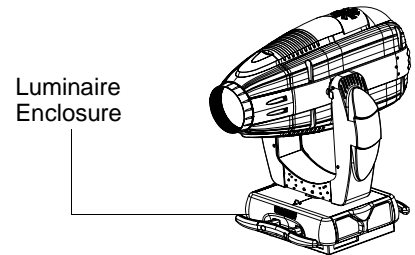

Figure 2-6: Floor Mounting

Connecting Data and Power

A maximum of 32 luminaires may be connected in any one DMX data link.

Note: This maximum limit applies to the luminaire "daisy chain" only. Your system or console may require fewer luminaires on a single data link path. Consult your console documentation for more information.

To connect power and data:

- Step 1. Connect data cable from console to first luminaire in chain at DATA IN connector.
- Step 2. If required, connect additional data cables from DATA THRU connectors to DATA IN connectors of remaining luminaires in link.
- Step 3. At last luminaire in link, install a DMX termination connector at DATA THRU connector. (Luminaires and other devices on the same DMX chain may not function properly without termination.)
- Step 4. Connect AC input cable connector to power input source.
- Step 5. Dress AC input and data cables and secure them so that they will not interfere with luminaire head and yoke movement.

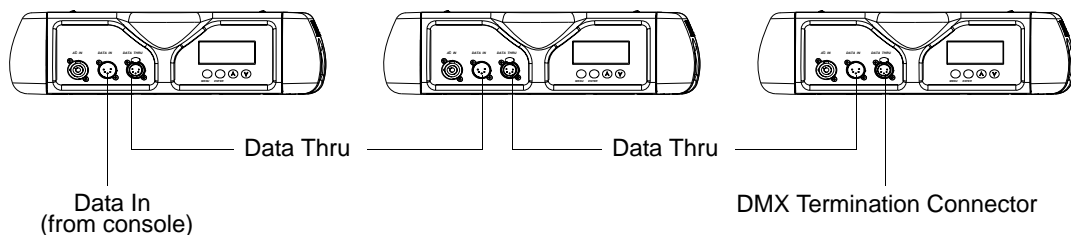

Figure 2-7: Connecting Power and Data

Powering Up

Power Up and Configuration Procedure

Since Lamp OFF is the default state, the lamp will not strike when the luminaire is powered up for the first time when AC input power cable is connected and power is applied, the luminaire will immediately begin a calibration sequence that steps it through pan and tilt movements. The internal color, gobo, and beam mechanisms will also move through a full range of motion. After calibration, the luminaire head will either stop at its "home" position (which positions the pan axis at mid-rotation and the head parallel to the yoke with the lens pointing away from the luminaire upper enclosure) or move to its current DMX-defined position if DMX data is present. All internal mechanisms also move to their "home" or DMX-defined positions.

Subsequently, depending on the luminaire's setting for Lamp Power-Up State (refer to [“VL3015LT Spot Menu System Function Chart” on page 51](#)), when power is applied, the arc lamp will either:

- a. "strike" or ignite - Lamp ON (*Lamp ON must be set through the luminaire's menu system or via a console command*),
- b. await calibration completion and then strike - Cal On, or
- c. await manual command to strike - Lamp Off (*default state*).



CAUTION: Before applying power, be sure the luminaire is hung or positioned so that the head and yoke can move freely without restriction. Make sure service tilt and pan locks are disengaged so luminaire moves freely.

To power up:

- At each luminaire, apply power by connecting luminaire to input power source (200 to 240VAC). Luminaire will automatically step through following procedure:
 - a. If Lamp Power-Up State is set to Lamp ON, lamp will strike (ignite). *NOTE: Lamp OFF is DEFAULT state from the factory.*
 - b. Luminaire will cycle through calibration and stop at "home" position.
 - c. If Lamp Power-Up State is set to Cal On, lamp will strike (ignite) at end of calibration sequence.

Addressing

Program Starting Address

The address setting for DMX console controlled systems is entered using the Menu Display (refer to [“Menu Operation” on page 48](#)). The luminaire retains the DMX address even if power is removed.

Note: Refer to your console operating instructions for specific information regarding its addressing requirements.

Program a DMX starting address:

- Step 1. Press [Menu].
- Step 2. Press [Up] / [Down] arrows until Address appears. Press [Enter].
- Step 3. Press [Up] / [Down] arrows to enter starting address.
- Step 4. Press [Enter] to set.

Program Starting Address Without Calibrating Luminaire

It is possible to bypass the calibration sequence and go directly to the Menu Display programming in order to pre-program an address setting.

Program starting address without calibrating luminaire:

- While powering up luminaire, press and hold [Menu]. Program address as in [Program Starting Address](#) above.
- Press and hold [Menu] until display changes from "Starting" to the DMX address.

Note: The luminaire will require a reset to restore control. See [“VL3015LT Spot Control Channel Functions” chapter on page 26](#) for control channel information on luminaire reset.

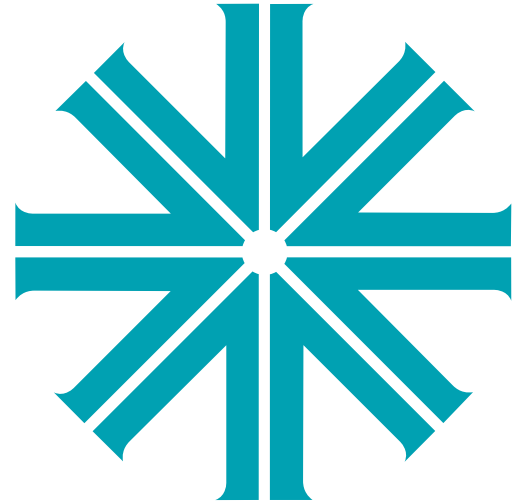

CHAPTER 3.

Operation

This chapter contains instructions for operating the luminaire using DMX control and for updating the internal software.

- **VL3015LT Spot DMX Channels**
- **VL3015LT Spot DMX Mapping**
- **VL3015LT Spot Luminaire Timing**
- **Updating Software**

VL3015LT Spot DMX Channels

VL3015LT Spot Channel Mapping

These tables assume a DMX start address of 1. When a different starting address is used, this address becomes channel 1 function and other functions follow in sequence.

Table 1: VL3015LT Spot DMX Channel Mapping

DMX Channel	Parameters	Range (DMX)	Range (%)	Default Value	Description
1	Intensity	0 - 255	0 - 100%	0	Linear Intensity control from 0 (closed) to 255 (open).
2	Pan Hi Byte	0 - 65535	0 - 100%	32767	16 bit control of Pan 540° of movement.
3	Pan Low Byte				
4	Tilt Hi Byte	0 - 65535	0 - 100%	32767	16 bit control of Tilt 270° of movement.
5	Tilt Low Byte				
6	Edge Hi Byte	0 - 65535	0 - 100%	32767	16 bit control of Edge from 0 to 65535.
7	Edge Low Byte				
8	Zoom Hi Byte	0 - 65535	0 - 100%	32767	16 bit control of Zoom from 0 (6 deg) to 65535 (60 deg).
9	Zoom Low Byte				
10	CTO	0 - 255	0 - 100%	0	Controls CTO color wheel. 0 (open) to 255 (full saturation).
11	Cyan	0 - 255	0 - 100%	0	Controls Cyan color wheel. 0 (open) to 255 (full saturation).
12	Yellow	0 - 255	0 - 100%	0	Controls Yellow color wheel. 0 (open) to 255 (full saturation).
13	Magenta	0 - 255	0 - 100%	0	Controls Magenta color wheel. 0 (open) to 255 (full saturation).
14	Fixed Color Wheel 1	0 - 255	0 - 100%	0	Controls Fixed color wheel 1. Linear control from 0 to 216. From 217 to 255 will give different speeds of wheel spin. Center color DMX values are denoted by (bold) type face. Position 1 = Open DMX = 0 - 18 (0) Position 2 = Red DMX = 19 - 53 (36) Position 3 = Yellow DMX = 54 - 89 (72) Position 4 = Magenta DMX = 90 - 125 (108) Position 5 = Kelly Green DMX = 126 - 161 (144) Position 6 = Congo Blue DMX = 162 - 198 (180) Wheel Spin Fast to Slow DMX = 217 - 234 Stop DMX = 235 - 237 Wheel Spin Slow to Fast DMX = 238 - 255
15	Fixed Color Wheel 2	0 - 255	0 - 100%	0	Controls Fixed color wheel 2. Linear control from 0 to 216. From 217 to 255 will give different speeds of wheel spin. Center color DMX values are denoted by (bold) type face. Position 1 = Open DMX = 0 - 18 (0) Position 2 = Blue DMX = 19 - 53 (36) Position 3 = Amber DMX = 54 - 89 (72) Position 4 = Fuchsia DMX = 90 - 125 (108) Position 5 = Orange DMX = 126 - 161 (144) Position 6 = Green DMX = 162 - 198 (180) Wheel Spin Fast to Slow DMX = 217 - 234 Stop DMX = 235 - 237 Wheel Spin Slow to Fast DMX = 238 - 255

Table 1: VL3015LT Spot DMX Channel Mapping

DMX Channel	Parameters	Range (DMX)	Range (%)	Default Value	Description
16	Gobo Wheel 1	0 - 255	0 - 100%	0	Controls Rotating Gobo Wheel 1 using the following DMX values. Half gobo positioning not possible. Position 1 = Open (Indx) DMX = 0 - 10 Position 2 = Alpha Rays (Indx) DMX = 11 - 32 Position 3 = Night Sky (Indx) DMX = 33 - 54 Position 4 = Five Ray (Indx) DMX = 55 - 75 Position 5 = Block Breakup (Indx) DMX = 76 - 97 Position 1 = Open (Rtate) DMX = 98 - 119 Position 2 = Alpha Rays (Rtate) DMX = 120 - 141 Position 3 = Night Sky (Rtate) DMX = 142 - 163 Position 4 = Five Ray (Rtate) DMX = 164 - 184 Position 5 = Block Breakup (Rtate) DMX = 185 - 206 Position 1 = Open DMX = 207 - 216 Wheel Spin Fast to Slow DMX = 217 - 236 Wheel Spin Slow to Fast DMX = 237 - 255
17	G1 Index Rt - High	0 - 65535	0 - 100%	32767	16 bit control of Gobo 1 Index and Rotation in either direction.
18	G1 Index Rt - Low				
19	Gobo Wheel 2	0 - 255	0 - 100%	0	Controls Rotating Gobo Wheel 2 using the following DMX values. Half gobo positioning not possible. Position 1 = Open (Indx) DMX = 0 - 10 Position 2 = Plowed (Indx) DMX = 11 - 32 Position 3 = Droplets (Indx) DMX = 33 - 54 Position 4 = On The Rocks (Indx) DMX = 55 - 75 Position 5 = Pangea (Indx) DMX = 76 - 97 Position 1 = Open (Rtate) DMX = 98 - 119 Position 2 = Plowed (Rtate) DMX = 120 - 141 Position 3 = Droplets (Rtate) DMX = 142 - 163 Position 4 = On The Rocks (Rtate) DMX = 164 - 184 Position 5 = Pangea (Rtate) DMX = 185 - 206 Position 1 = Open DMX = 207 - 216 Wheel Spin Fast to Slow DMX = 217 - 236 Wheel Spin Slow to Fast DMX = 237 - 255
20	G2 Index Rt - High	0 - 65535	0 - 100%	32767	16 bit control of Gobo 2 Index and Rotation in either direction.
21	G2 Index Rt - Low				
22	Gobo Wheel 3	0 - 255	0 - 100%	0	Controls Rotating Gobo Wheel 3 using the following DMX values. Half gobo positioning not possible. Position 1 = Open (Indx) DMX = 0 - 10 Position 2 = Circle of Ovals (Indx) DMX = 11 - 32 Position 3 = Multi-Color Circles (Indx) DMX = 33 - 54 Position 4 = Pebbles (Indx) DMX = 55 - 75 Position 5 = Uneven Bars (Indx) DMX = 76 - 97 Position 1 = Open (Rtate) DMX = 98 - 119 Position 2 = Circle of Ovals (Rtate) DMX = 120 - 141 Position 3 = Multi-Color Circles (Rtate) DMX = 142 - 163 Position 4 = Pebbles (Rtate) DMX = 164 - 184 Position 5 = Uneven Bars (Rtate) DMX = 185 - 206 Position 1 = Open DMX = 207 - 216 Wheel Spin Fast to Slow DMX = 217 - 236 Wheel Spin Slow to Fast DMX = 237 - 255
23	G3 Index Rt - High	0 - 65535	0 - 100%	32767	16 bit control of Gobo 3 Index and Rotation in either direction.
24	G3 Index Rt - Low				
25	Beam Iris	0 - 255	0 - 100%	0	Controls beam size iris from 0 (Open) to 255 (small).
26	Frost	0 - 255	0 - 100%	0	Linear frost control from no frost (0) to full frost (255).

Table 1: VL3015LT Spot DMX Channel Mapping

DMX Channel	Parameters	Range (DMX)	Range (%)	Default Value	Description
27	Prism	0 - 255	0 - 100%	0	Inserts Prism into beam for prism effects. Open (Out of Beam) DMX = 0 - 2 Prism Index DMX = 3 - 127 Prism Rotate DMX = 128 - 255
28	Prism Rt - High	0 - 65535	0 - 100%	32767	16 bit control of Prism Index and Rotation in either direction.
29	Prism Rt - Low				
30	Strobe	0 - 255	0 - 100%	0	Controls strobe operations as follows . . . Open DMX = 0 - 2 Closed DMX = 3 - 5 Slow Rand DMX = 6 - 7 Med Rand DMX = 8 - 10 Fast Rand DMX = 11 - 12 Strobe Range DMX = 13 - 127 (fastest)
31	Range	0 - 255	0 - 100%	0	Applies different tables to optics mechanism, depending on throw distances. Used for achieving maximum optical quality of zoom and edge.
32	Focus Time	0 - 255	0 - 100%	255	Allows for luminaire timing of pan and tilt. Profile should default to DMX 255 for smoothest console fade times.
33	Color Time	0 - 255	0 - 100%	255	Allows for luminaire timing of color wheels. Profile should default to DMX 255 for smoothest console fade times.
34	Beam Time	0 - 255	0 - 100%	255	Allows for luminaire timing of beam and variable frost. Profile should default to DMX 255 for smoothest console fade times.
35	Gobo Time	0 - 255	0 - 100%	255	Allows for luminaire timing of gobo wheel and prism functions. Profile should default to DMX 255 for smoothest console fade times.
36	Control	0 - 255	0 - 100%	0	Used to strike/douse the lamp, set lamp levels, and other various functions, as well as resetting the luminaire via the console. DMX values are: Default Console Value (Idle) = DMX 0 Display-Menu Settings/Off = DMX 3 - 4 Reset Fixture to Defaults = DMX 5 - 7 *Color Snap ON = DMX 20 - 25 *Color Snap OFF (Norm) = DMX 30 - 35 *Dimmer Snap ON = DMX 40 - 45 *Dimmer Snap OFF (Norm) = DMX 50 - 55 Full Luminaire ReCal = DMX 81 - 87 ReCal Color = DMX 100 - 104 ReCal Gobo = DMX 112 - 116 ReCal Beam = DMX 126 - 130 ReCal Dim/Strobe = DMX 138 - 142 Lamp OFF = DMX 165 - 171 Lamp Low = DMX 176 - 184 Lamp Med = DMX 189 - 194 Lamp High = DMX 199 - 204 Lamp Strike = DMX 249 - 255 When resetting fixtures to Defaults, settings in Bold will be activated. * Note that these functions do not require the 3 sec rule to execute. All other values do require the 3 sec rule.

Notes:

- Default Values: Denotes recommended console default settings.
- Use of Timing Channels: The default value setting in the profile should be 255 (proportional control) to allow smooth movement when using console timing. The Timing channel data should change as a snap. A zero value will give the fastest move but without any smoothing, this can look stepy in console-timed moves.

- To use a timing channel instead of console timing it is necessary to set the timing channel to the desired value and set cue and/or parameter time to zero. A combination of time controls can produce unexpected results. Refer to [“VL3015LT Spot Timing Channel Information”](#) on page 35 for more information.
- Timing Channel Control: The luminaire uses the timing channel value to calculate a smooth continuous movement for a given time and transition.

VL3015LT Spot Control Channel Functions

Control channel functions allow special actions such as reset, lamp on/off and partial recalibration. These must be executed with zero time transition or with timing disabled. Discrete values must be used; not manual controls such as faders or encoders (see chart below for values).

Reset - resets all luminaire mechanisms.

Lamp On or Lamp Off (*note, default setting is Lamp Off*) - switches lamp on or off.

Partial Recalibration - resets only the target mechanism (color, gobo, zoom, etc.) without affecting others.

Table 3-1: VL3015LT Spot Control Channel

DMX Channel	Parameters	Range (DMX)	Range (%)	Default Value	Description
36	Control	0 - 255	0 - 100%	0	<p>Used to strike/douse the lamp, set lamp levels, and other various functions, as well as resetting the luminaire via the console. DMX values are:</p> <p>Default Console Value (Idle) = DMX 0 Display-Menu Settings/Off = DMX 3 - 4 Reset Fixture to Defaults = DMX 5 - 7 *Color Snap ON = DMX 20 - 25 *Color Snap OFF (Norm) = DMX 30 - 35 *Dimmer Snap ON = DMX 40 - 45 *Dimmer Snap OFF (Norm) = DMX 50 - 55 Full Luminaire ReCal = DMX 81 - 87 ReCal Color = DMX 100 - 104 ReCal Gobo = DMX 112 - 116 ReCal Beam = DMX 126 - 130 ReCal Dim/Strobe = DMX 138 - 142 Lamp OFF = DMX 165 - 171 Lamp Low = DMX 176 - 184 Lamp Med = DMX 189 - 194 Lamp High = DMX 199 - 204 Lamp Strike = DMX 249 - 255</p> <p>When resetting fixtures to Defaults, settings in Bold will be activated.</p> <p>* Note that these functions do not require the 3 sec rule to execute. All other values do require the 3 sec rule.</p>

To use control channel functions:

- Step 1. Select an action to be sent.
- Step 2. Set control channel value for desired action (for example, 84 for ReCal). Hold value for 3 seconds.
- Step 3. Set control channel value to zero. (This must occur without any scaling values. Action will be voided if other values are detected between action value and zero.)

Note: A numerical keypad is suggested for sending values. An encoder or fader does not allow for a quick value change, which is required to effect the control functions.

VL3015LT Spot DMX Mapping

VL3015LT Spot Color Control

The luminaire's color system is composed of a CMY color mixing mechanism and two fixed color wheels. The follow sections describe these components.

Color Mixing

The color mixing mechanism is made up of four graduated color disks: cyan, magenta, yellow and CTO (color temperature orange). These disks provide full-spectrum color crossfades from pastel to saturated color.

Table 3-2: DMX Map for Cyan, Magenta, Yellow and CTO Colors

% Value	DMX Value	Action
0	0	Open
100	255	Full Saturation

Fixed Color Wheel 1

Fixed color wheel 1 offers timed changes, half and full frame positions, and various spin rates in either direction. The wheel contains six positions, one being open. The following illustration (Figure 3-1) shows the standard positions and color configuration for fixed color wheel 1:

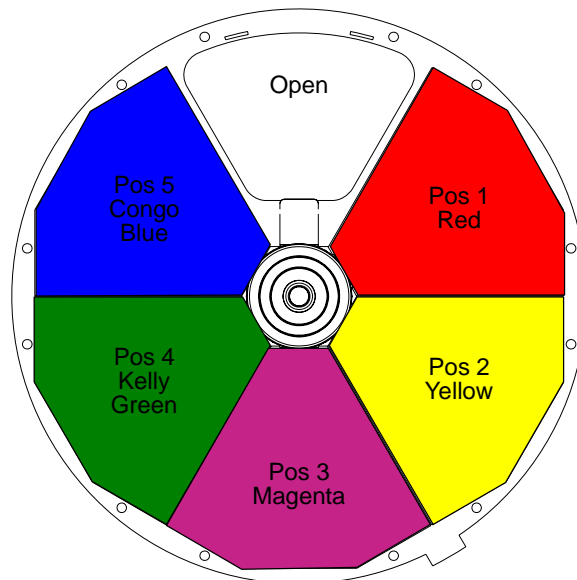

Note:
Color are simulated
and are for position
reference only.

Figure 3-1: Fixed Color Wheel 1 Standard Filters / Positions

Table 3-3: VL3015LT Spot Fixed Color Wheel 1 Standard Configuration Chart

Position	Color Filter	Part Number
1	Red	41.9686.0490
2	Yellow	41.9686.0491
3	Magenta	41.9686.0492
4	Kelly Green	41.9686.0493
5	Congo Blue	41.9686.0494

Fixed Color Wheel 2

Fixed color wheel 2, like fixed color wheel 1, offers timed changes, half and full frame positions, and various spin rates in either direction. The wheel contains six positions, one being open. The following illustration (Figure 3-2) shows the standard positions and color configuration for fixed color wheel 2:

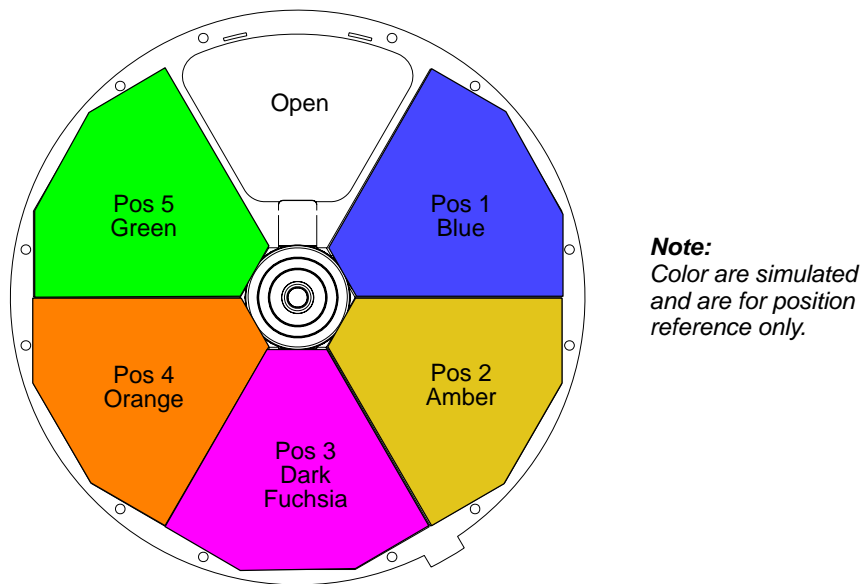

Figure 3-2: Fixed Color Wheel 2 Standard Filters / Positions

Table 3-4: VL3015LT Spot Fixed Color Wheel 2 Standard Configuration Chart

Position	Color Filter	Part Number
1	Blue	41.9686.0495
2	Amber	41.9686.0496
3	Dark Fuchsia	41.9686.0497
4	Orange	41.9686.0498
5	Green	41.9686.0499

Fixed Color Wheels DMX Map

Table 3-5: VL3015LT Spot DMX Map for Fixed Color Wheels 1 and 2

DMX Channel	Parameters	Range (DMX)	Range (%)	Default Value	Description
14	Fixed Color Wheel 1	0 - 255	0 - 100%	0	<p>Controls Fixed color wheel 1. Linear control from 0 to 216. From 217 to 255 will give different speeds of wheel spin. Center color DMX values are denoted by (bold) type face.</p> <p>Position 1 = Open DMX = 0 - 18 (0) Position 2 = Red DMX = 19 - 53 (36) Position 3 = Yellow DMX = 54 - 89 (72) Position 4 = Magenta DMX = 90 - 125 (108) Position 5 = Kelly Green DMX = 126 - 161 (144) Position 6 = Congo Blue DMX = 162 - 198 (180) Wheel Spin Fast to Slow DMX = 217 - 234 Stop DMX = 235 - 237 Wheel Spin Slow to Fast DMX = 238 - 255</p>
15	Fixed Color Wheel 2	0 - 255	0 - 100%	0	<p>Controls Fixed color wheel 2. Linear control from 0 to 216. From 217 to 255 will give different speeds of wheel spin. Center color DMX values are denoted by (bold) type face.</p> <p>Position 1 = Open DMX = 0 - 18 (0) Position 2 = Blue DMX = 19 - 53 (36) Position 3 = Amber DMX = 54 - 89 (72) Position 4 = Fuchsia DMX = 90 - 125 (108) Position 5 = Orange DMX = 126 - 161 (144) Position 6 = Green DMX = 162 - 198 (180) Wheel Spin Fast to Slow DMX = 217 - 234 Stop DMX = 235 - 237 Wheel Spin Slow to Fast DMX = 238 - 255</p>

VL3015LT Spot Beam Control

Strobe

Table 3-6: VL3015 Spot DMX Map for Strobe

DMX Channel	Parameters	Range (DMX)	Range (%)	Default Value*	Description
30	Strobe	0 - 255	0 - 100%	0	<p>Controls strobe operations as follows . . .</p> <p>Open DMX = 0 - 2 Closed DMX = 3 - 5 Slow Rand DMX = 6 - 7 Med Rand DMX = 8 - 10 Fast Rand DMX = 11 - 12 Strobe Range DMX = 13 - 127 (fastest)</p>

Range

The Range channel is used to fine tune the focus range of the fixture. If the image can not be made sharp after adjusting the edge and zoom, adjust the range channel to gain sharpness of the image.

Table 3-7: VL3015 Spot DMX Map for Range

DMX Channel	Parameters	Range (DMX)	Range (%)	Default Value*	Description
31	Range	0 - 255	0 - 100%	0	Applies different tables to optics mechanism, depending on throw distances. Used for achieving maximum optical quality of zoom and edge.

VL3015LT Spot Gobo/Effects Control

Overview of Gobos and Gags used in VL3015LT Spot Luminaire

Due to the immense energy and light produced by VL3015LT spot luminaires, Vari-Lite recommends to users and owners of this fixture follow the guidelines outlined below when loading gobos or gags in any of the three rotating gobo wheels.

Gobo / Gag Use and Positioning

Vari-Lite has purposely selected a set of standard gobos and gags for this fixture and positioned them within the fixture to offer optimum versatility / performance. The gobos supplied - in the standard factory configuration - have been tested in their respective original positions to protect their service life (including when morphed between wheels 1 and 3).

Note: For standard factory gobo / gag loads and position, please refer to the information contained in [“Gobo Wheels 1, 2, and 3” on page 31](#) of this manual.

Users can load their own patterns (gobos or gags). When using custom gobos or gags, Vari-Lite recommends the following guidelines:

- When morphing gobos, gobos should be morphed between wheels 1 and 3 only, never in wheel 2.
- Rotating gobo wheel 2 has been designated the gag (effects) wheel. Wheel 2 should only house clear type gags or gobos that permit minimum unabated light transmission.
- Under no circumstances should owners or users use or install metal gobos. Using metal gobos in the VL3015LT spot luminaire will void the fixture’s warranty.



Note: Vari-Lite cannot guarantee the service life of any custom gobos or gags when used in conjunction with this fixture. Owners and users employing custom gobos and gags do so at their own risk.

Gobo Wheels 1, 2, and 3

These wheels have five positions, one being open. [Figure 3-3](#) illustrates the standard gobo configurations:

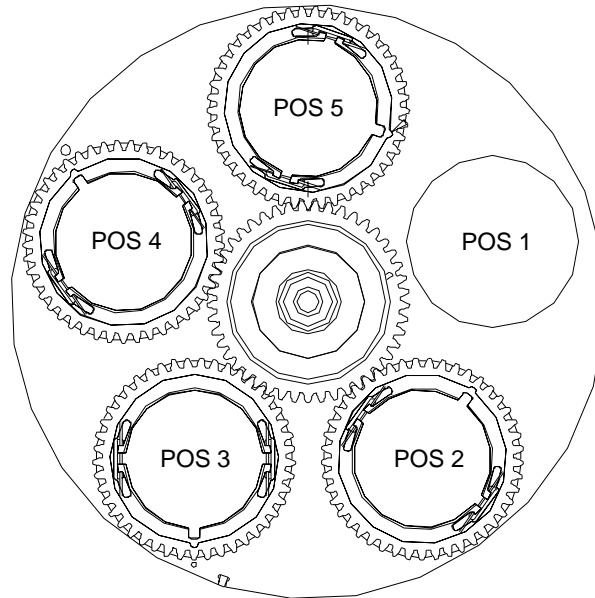

Figure 3-3: Gobo Wheels 1, 2 and 3 Positions

For each wheel and their associated standard gobo or gag, refer to:

- [“VL3015LT Spot Gobo Wheel 1 Standard Configuration Chart” on page 32.](#)
- [“VL3015LT Spot Gobo Wheel 2 Standard Configuration Chart” on page 32.](#)
- [“VL3015LT Spot Gobo Wheel 3 Standard Configuration Chart” on page 33.](#)

Table 3-8: VL3015LT Spot Gobo Wheel 1 Standard Configuration Chart

Position	Gobo Style	Part Number
1	Open	No Gobo (N/A)
2	Alpha Rays	41.6098.7029
3	Night Sky	41.6098.5011
4	Ray	41.6098.4003
5	Block Break-Up	41.6098.7015

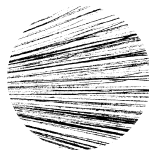

Alpha Rays

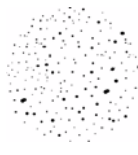

Night Sky



Ray



Block Break-Up

Note: _____
 Raw artwork shown for
 gobos and gags is for
 reference only.

Table 3-9: VL3015LT Spot Gobo Wheel 2 Standard Configuration Chart

Position	Gobo Style	Part Number
1	Open	No Gobo (N/A)
2	Plowed	41.6098.8513
3	Droplets Gag	41.6098.8506
4	On The Rocks	41.6098.8511
5	Pangea	41.6098.8512



Plowed

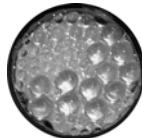

Droplets Gag



On The Rocks



Pangea

Note: _____
 Raw artwork shown for
 gobos and gags is for
 reference only.

Table 3-10: VL3015LT Spot Gobo Wheel 3 Standard Configuration Chart

Position	Gobo Style	Part Number
1	Open	No Gobo (N/A)
2	Circle of Ovals	41.6098.6011
3	Multi-Color Circles	41.6098.8801
4	Pebbles	41.6098.7002
5	Uneven Bars	41.6098.4211



Circle of Ovals

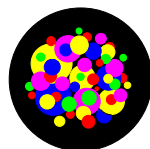

Multi-Color Circles



Pebbles



Uneven Bars

Note: _____
 Raw artwork shown for gobos and gags is for reference only.

Index and Rotation

The gobo wheels operate in two modes: INDEX Mode and ROTATE Mode. The corresponding values are given in the DMX Map Tables below. Gobos will also behave as follows:

- Gobo wheels will only stop at whole images.
- Timed moves are only available using the Gobo Time channel (27).
- Spins are variable from DMX 217-236 for CCW fast to slow, and 237-255 for CW slow to fast.
- The Gobo Index function utilizes 16-bit control which offers enhanced resolution whether in INDEX or ROTATE mode.

Table 3-11: VL3015LT Spot DMX Map for Gobo Wheel 1, 2 and 3

DMX Channel	Parameters	Range (DMX)	Range (%)	Default Value*	Description
16	Gobo Wheel 1	0 - 255	0 - 100%	0	Controls Rotating Gobo Wheel 1 using the following DMX values. Half gobo positioning not possible. Position 1 = Open (Indx) DMX = 0 - 10 Position 2 = Alpha Rays (Indx) DMX = 11 - 32 Position 3 = Night Sky (Indx) DMX = 33 - 54 Position 4 = Shock Breakup (Indx) DMX = 55 - 75 Position 5 = Block Breakup (Indx) DMX = 76 - 97 Position 1 = Open (Rtate) DMX = 98 - 119 Position 2 = Alpha Rays (Rtate) DMX = 120 - 141 Position 3 = Night Sky (Rtate) DMX = 142 - 163 Position 4 = Shock Breakup (Rtate) DMX = 164 - 184 Position 5 = Block Breakup (Rtate) DMX = 185 - 206 Position 1 = Open DMX = 207 - 216 Wheel Spin Fast to Slow DMX = 217 - 236 Wheel Spin Slow to Fast DMX = 237 - 255
17	G1 Index Rt - High	0 - 65535	0 - 100%	32767	16 bit control of Gobo 1 Index and Rotation in either direction.
18	G1 Index Rt - Low				

Table 3-11: VL3015LT Spot DMX Map for Gobo Wheel 1, 2 and 3

19	Gobo Wheel 2	0 - 255	0 - 100%	0	<p>Controls Rotating Gobo Wheel 2 using the following DMX values. Half gobo positioning not possible.</p> <p>Position 1 = Open (Indx) DMX = 0 - 10 Position 2 = Plowed (Indx) DMX = 11 - 32 Position 3 = Droplets (Indx) DMX = 33 - 54 Position 4 = On The Rocks (Indx) DMX = 55 - 75 Position 5 = Pangea (Indx) DMX = 76 - 97 Position 1 = Open (Rtate) DMX = 98 - 119 Position 2 = Plowed (Rtate) DMX = 120 - 141 Position 3 = Droplets (Rtate) DMX = 142 - 163 Position 4 = On The Rocks (Rtate) DMX = 164 - 184 Position 5 = Pangea (Rtate) DMX = 185 - 206 Position 1 = Open DMX = 207 - 216</p> <p>Wheel Spin Fast to Slow DMX = 217 - 236 Wheel Spin Slow to Fast DMX = 237 - 255</p>
20	G2 Index Rt - High	0 - 65535	0 - 100%	32767	16 bit control of Gobo 2 Index and Rotation in either direction.
21	G2 Index Rt - Low				
22	Gobo Wheel 3	0 - 255	0 - 100%	0	<p>Controls Rotating Gobo Wheel 3 using the following DMX values. Half gobo positioning not possible.</p> <p>Position 1 = Open (Indx) DMX = 0 - 10 Position 2 = Circle of Ovals (Indx) DMX = 11 - 32 Position 3 = Multi-Color Circles (Indx) DMX = 33 - 54 Position 4 = Pebbles (Indx) DMX = 55 - 75 Position 5 = Uneven Bars (Indx) DMX = 76 - 97 Position 1 = Open (Rtate) DMX = 98 - 119 Position 2 = Circle of Ovals (Rtate) DMX = 120 - 141 Position 3 = Multi-Color Circles (Rtate) DMX = 142 - 163 Position 4 = Pebbles (Rtate) DMX = 164 - 184 Position 5 = Uneven Bars (Rtate) DMX = 185 - 206 Position 1 = Open DMX = 207 - 216</p> <p>Wheel Spin Fast to Slow DMX = 217 - 236 Wheel Spin Slow to Fast DMX = 237 - 255</p>
23	G3 Index Rt - High	0 - 65535	0 - 100%	32767	16 bit control of Gobo 3 Index and Rotation in either direction.
24	G3 Index Rt - Low				

VL3015LT Spot Luminaire Timing

VL3015LT Spot Timing Channel Information

Timing channel control improves the timed moves of certain groups of parameters. We provide up to four timing channels - Focus (pan and tilt), Color Time (color parameters), Beam Time (beam parameters), and Gobo Time (gobo wheel operation).

Types of timing control:

- **Timing Control Channel:** the luminaire uses its timing channel value to calculate a smooth continuous movement for a given time and transition.
- **Console Timing:** the console calculates the time duration between the DMX increments to be sent for a given time and transition.

Guidelines:

- Timing channels support time values of up to six minutes.
- To use a timing channel instead of console timing, it is necessary to set the timing channel to the desired value and set cue and/or parameter time to zero. A combination of time controls can produce unexpected results.
- The default value setting in the profile should be 255 (proportional control) to allow smooth movement when using console timing.
- The timing channel data should change as a snap. A zero value will give the fastest move, however, without any smoothing this can appear "steppy" in console timed moves.

Note: Some parameters have been excluded from the timing channels. Wheel spin and gobo rotation rate changes are not affected by timing channels.

Table 3-12: VL3015LT Spot Luminaire Channel Function / Timing Channel Relationship

Channel Function	Timing Channel			
	Focus Time	Color Time	Beam Time	Gobo Time
Pan (Hi Byte/Lo Byte)	◆			
Tilt (Hi Byte/Lo Byte)	◆			
Cyan		◆		
Magenta		◆		
Yellow		◆		
CTO		◆		
Color Wheels		◆		
Beam Iris			◆	
Gobo Wheels 1, 2 and 3				◆

A timing value of zero is full speed. A time value of 100% (or DMX 255) enables the associated parameter(s) to follow cue fade time (console time) rather than the timing channel.

Note: The particular storing syntax for your console, as well as instructions on how to write part cues, can be found in the operation manual for that console.

To use these channels, you must:

- Step 1. Create the cue, including color, gobo, edge and frost as required.
- Step 2. Decide which fixtures and which parameter groups will use timing channels.
- Step 3. Assign a value to the particular timing channel(s) you wish to use (for timing information, see chart on next page).
- Step 4. Set console timing (or cue fade time) for parameters and timing channels to zero seconds.
- Step 5. Store cue.

Note: Avoid changing timing channel values in a fading cue. This can cause unexpected behavior in the luminaire as the timing channel value is updated over time. Timing channel values and the final destination of the parameters affected by the timing channel should always be sent in a zero count.

Timing channels can be set in either % or 0-255 (DMX) modes, with the following values assigned:

Table 3-13: Timing Channels Map

% Value	DMX	= Seconds
0	0	Full Speed
	1	0.2
	2	0.4
1	3	0.6
	4	0.8
2	5	1
	6	1.2
	7	1.4
3	8	1.6
	9	1.8
4	10	2
	11	2.2
	12	2.4
5	13	2.6
	14	2.8
6	15	3
	16	3.2
	17	3.4
7	18	3.6
	19	3.8
8	20	4
	21	4.2

Table 3-13: Timing Channels Map (Continued)

% Value	DMX	= Seconds
	22	4.4
9	23	4.6
	24	4.8
10	25	5
	26	5.2
	27	5.4
11	28	5.6
	29	5.8
	30	6
12	31	6.2
	32	6.4
13	33	6.6
	34	6.8
	35	7.0
14	36	7.2
	37	7.4
15	38	7.6
	39	7.8
	40	8
16	41	8.2
	42	8.4
17	43	8.6
	44	8.8
	45	9
18	46	9.2
	47	9.4
19	48	9.6
	49	9.8
	50	10
20	51	10.2
	52	10.4
	53	10.6
21	54	11
	55	11
22	56	12
	57	12
	58	13
23	59	13
	60	14
24	61	14

Table 3-13: Timing Channels Map (Continued)

% Value	DMX	= Seconds
	62	14
	63	15
25	64	15
	65	16
26	66	16
	67	16
	68	17
27	69	17
	70	18
28	71	18
	72	18
	73	19
29	74	19
	75	20
30	76	20
	77	20
	78	21
31	79	21
	80	21
	81	22
32	82	22
	83	23
33	84	23
	85	23
	86	24
34	87	24
	88	25
35	89	25
	90	25
	91	26
36	92	26
	93	27
37	94	27
	95	27
	96	28
38	97	28
	98	29
39	99	29
	100	29
	101	30
40	102	30
	103	30

Table 3-13: Timing Channels Map (Continued)

% Value	DMX	= Seconds
	104	31
41	105	31
	106	32
42	107	32
	108	32
	109	33
43	110	33
	111	34
44	112	34
	113	34
	114	35
45	115	35
	116	36
46	117	36
	118	36
	119	37
47	120	37
	121	38
48	122	38
	123	38
	124	39
49	125	39
	126	39
	127	40
50	128	40
	129	41
51	130	41
	131	41
	132	42
52	133	42
	134	43
53	135	43
	136	43
	137	44
54	138	44
	139	45
55	140	45
	141	45
	142	46
56	143	46
	144	47
57	145	47

Table 3-13: Timing Channels Map (Continued)

% Value	DMX	= Seconds
	146	47
	147	48
58	148	48
	149	49
59	150	49
	151	49
	152	50
60	153	50
	154	50
	155	51
61	156	51
	157	52
62	158	52
	159	52
	160	53
63	161	53
	162	54
64	163	54
	164	54
	165	55
65	166	55
	167	56
66	168	56
	169	56
	170	57
67	171	57
	172	58
68	173	58
	174	58
	175	59
69	176	59
	177	59
	178	60
70	179	60
	180	65
71	181	65
	182	65
	183	70
72	184	70
	185	75
73	186	75
	187	75

Table 3-13: Timing Channels Map (Continued)

% Value	DMX	= Seconds
	188	80
74	189	80
	190	85
75	191	85
	192	85
	193	90
76	194	90
	195	95
77	196	95
	197	95
	198	100
78	199	100
	200	110
79	201	110
	202	110
	203	120
80	204	120
	205	120
81	206	130
	207	130
	208	140
82	209	140
	210	140
	211	150
83	212	150
	213	160
84	214	160
	215	160
	216	170
85	217	170
	218	180
86	219	180
	220	180
	221	190
87	222	190
	223	200
88	224	200
	225	200
	226	210
89	227	210
	228	210
	229	220

Table 3-13: Timing Channels Map (Continued)

% Value	DMX	= Seconds
90	230	220
	231	230
91	232	230
	233	230
	234	240
92	235	240
	236	250
93	237	250
	238	250
	239	260
94	240	260
	241	270
95	242	270
	243	270
	244	280
96	245	280
	246	290
97	247	290
	248	290
	249	300
98	250	300
	251	310
99	252	310
	253	310
	254	310
100	255	Follows Cue Data

Updating Software

USB Download and Programming

To download files with a PC equipped with a Universal Serial Bus (USB) port, you need the VARI*LITE USB Luminaire Programming Kit (28.8500.0054). The USB Luminaire Programming Kit can be ordered directly from your Authorized VARI*LITE Dealer.

The VARI*LITE USB Luminaire Programming Kit (28.8500.0054) includes:

- VARI*LITE USB Upload Cable (25.9600.0001)
- USB Luminaire Programming Kit CD (87.8500.0002)
- Instruction Sheet (02.8500.0100)
- VARI*LITE carry bag (07.5044.0005)

Computer Requirements for the USB Luminaire Programming Kit

- PC running Microsoft® Windows®. Although the USB Luminaire Programming kit software is not directly compatible with Apple Macintosh® computers, it does run with some Windows emulators.
- In addition to Windows, your computer must be running IE 5.01 or later, and Microsoft.NET Framework Version 3.5 (or later), which you can download from <http://www.microsoft.com> and search for .NET Framework downloads.
- An available USB 2.0 port on the PC.
- For Windows Vista (64-Bit) and Windows 7 (64-Bit) operating systems, refer to the Vari-Lite Technical Notice TN-309 (in the product downloads section) on the Vari-Lite web site.

USB VLDownloader PC Program and .bin Luminaire Files

The USB VLDownloader program and current .bin files are available from the Product Downloads page at www.vari-lite.com. Instructions for installing the USB VLDownloader program on your PC are also available on the Product Downloads page. Use the USB VLDownloader program to transfer updated versions of the luminaire operating software (.bin files) from your PC to the luminaires.



Note: Refer to instruction sheet 02.8500.0100 for detailed programming instructions for VARI*LITE luminaires.

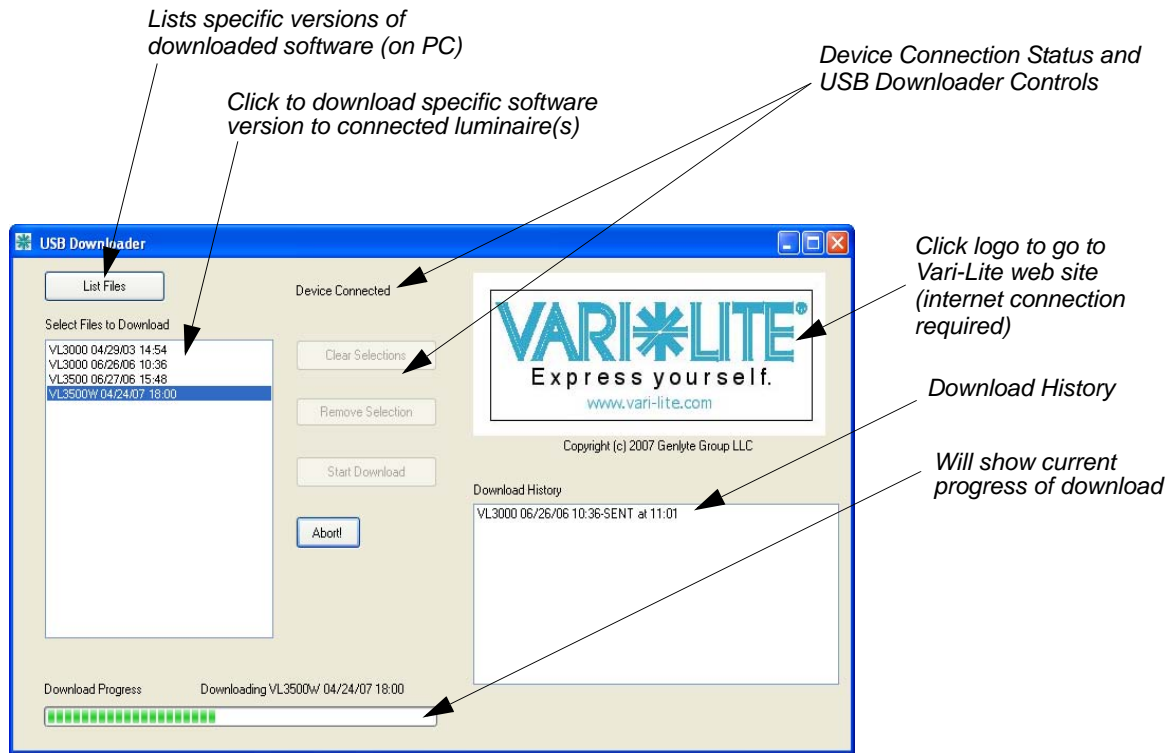

Figure 3-4: VL Download Program Window

Transferring Software From Luminaire to Luminaire

It is possible to transfer specific software versions between luminaires. As in the case of installing new software versions, multiple luminaires can be programmed at the same time if they are data linked together (refer to [“Connecting Data and Power” on page 18](#)), however a maximum of 32 luminaires can be updated at once.

Hardware Requirements

Data cables used in this process must have two twisted pairs and a shield. It is also recommended that cables meet all other USITT DMX specification requirements. Refer to [“Data Cables” on page 13](#).

A DMX termination connector is used in this process. Refer to [page 14](#) for more information regarding the construction of this connector.

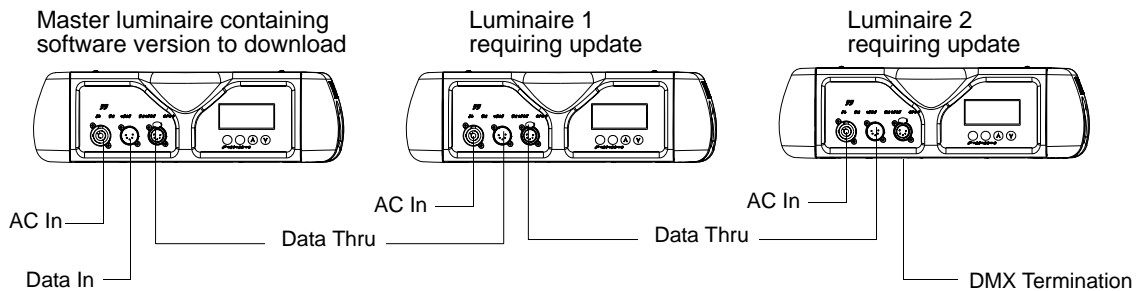

Figure 3-5: Software Transfer Setup

Transfer Procedure

This procedure is used to transfer software versions between luminaires.

- Step 1. At last luminaire, install DMX termination connector into DATA THRU XLR connector.
- Step 2. At master luminaire (first in chain) Menu Display, press [Menu].
- Step 3. Press [Up] / [Down] arrows until **Fixture** appears.
- Step 4. Press [Up] / [Down] arrows until **Download** appears. Press [Enter].
- Step 5. **OK?** will be displayed. Press [Enter] to accept.
- Step 6. Download will proceed. (Download will take 4-5 seconds.) The number of blocks displayed will be less in a luminaire-to-luminaire download than in a PC-to-luminaire download for the same software version.
- Step 7. Once download is complete, luminaire will automatically recalibrate. Once recalibration is complete, recalibrate luminaire one additional time.

Verify software version at luminaire:

- Step 1. At Menu Display, press [Menu].
- Step 2. Press [Up] / [Down] arrows until **Fixture** appears. Press [Enter].
- Step 3. Press [Up] / [Down] arrows until **Version** appears. Press [Enter].

The first half of the version will be displayed as a date (MM/DD/YY). For example, 03/18/03 (March 18, 2003).

Press [Enter] to display second half of version. This will be displayed as a time (HH:MM). For example, 16.36 = 4:36 pm)

Notes

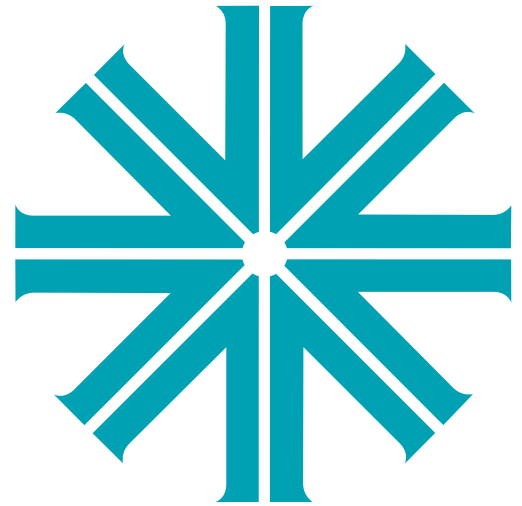

CHAPTER 4.

Menu System

This chapter contains instructions for operating the luminaire using the Menu Display feature.

- **Menu Operation**
- **Menu Functions**
- **Self-Tests**

Menu Operation

What Is the Menu System?

The menu system is a programmable set of commands used to configure, address, operate, and test the luminaire. The menu system is controlled at the Menu Display available at the enclosure input panel.

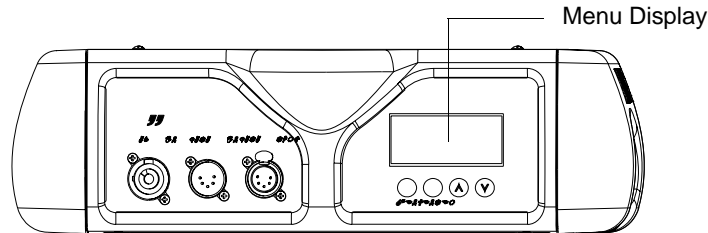

Figure 4-1: Menu Display Location

Controls Operation

The menu system is controlled by four buttons. These buttons function as follows:

[Menu] button. Displays the menu, or if at first level, the current address.

[Enter] button. Selects the current menu option or stores current data value.



[Up] arrow. Scrolls menu options upward or increases current data value.*



[Down] arrow. Scrolls menu options downward or decreases current data value.*

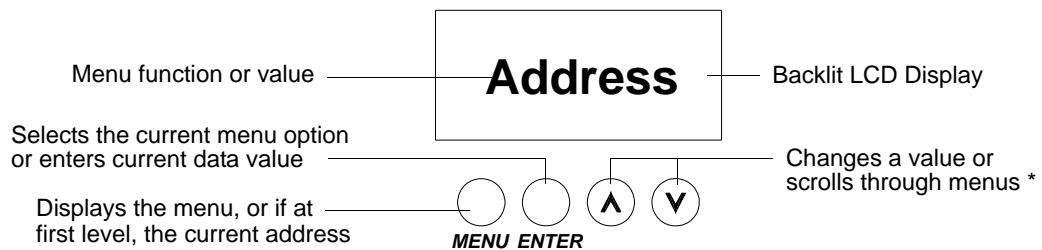

* The arrows will have opposite functions if the luminaire is hung upside down in a hanging orientation due to the automatic orientation feature. In other words, the arrow pointing downward always functions as down/decrease and the arrow pointing upward always functions as up/increase regardless of the luminaire orientation.

To enter the menu system, first press [Menu]. The functions displayed will be 1st level functions. Scroll through the 1st level functions by pressing [Up] / [Down] arrows. Once the desired function appears in the display, press [Enter]. You are now at the 2nd level. Once again, press the [Up] / [Down] arrows to scroll through 2nd level functions. Press [Enter] to access 3rd level functions and so forth. When the highest level for the function is reached, [Up] / [Down] arrows can be pressed to enter a value or select a toggle activation such as On/Off. Press [Enter] to store the value or select an action.

For example:

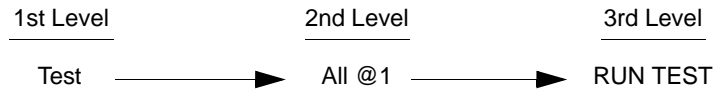

Default State

The menu display's default state during normal operation is to display the DMX address. After 10 seconds of inactivity at the display, it will change to the default state.

After longer periods of inactivity, the menu display will switch to its off state. The default state for this feature is 5 minutes, however, different time lengths can also be programmed.

To program a different time length for menu off feature:

- Step 1. Press [Menu].
- Step 2. Press [Up] / [Down] arrows until Config (Configuration) appears. Press [Enter].
- Step 3. Press [Up] / [Down] arrows to access Display. Press [Enter].
- Step 4. Press [Up] / [Down] arrows to select either 30 Sec (30 seconds), 5 Min (5 minutes), 10 Min (10 minutes), or ON (on indefinitely). Press [Enter] to set.

Shortcuts

A few button combinations are provided as shortcuts for frequently used menu functions. These shortcuts are as follows:

- Pressing [Enter] and [Up] at the same time = Lamp On
- Pressing [Enter] and [Down] at the same time = Lamp Off
- Pressing [Menu] and [Up] at the same time = Recalibrate
- Pressing [Menu] at Power up interrupts calibration. See [“Program Starting Address Without Calibrating Luminaire” on page 20](#) for more information.

Menu Functions

VL3015LT Spot Menu System Overview

The following is a graphic representation of the entire menu system.

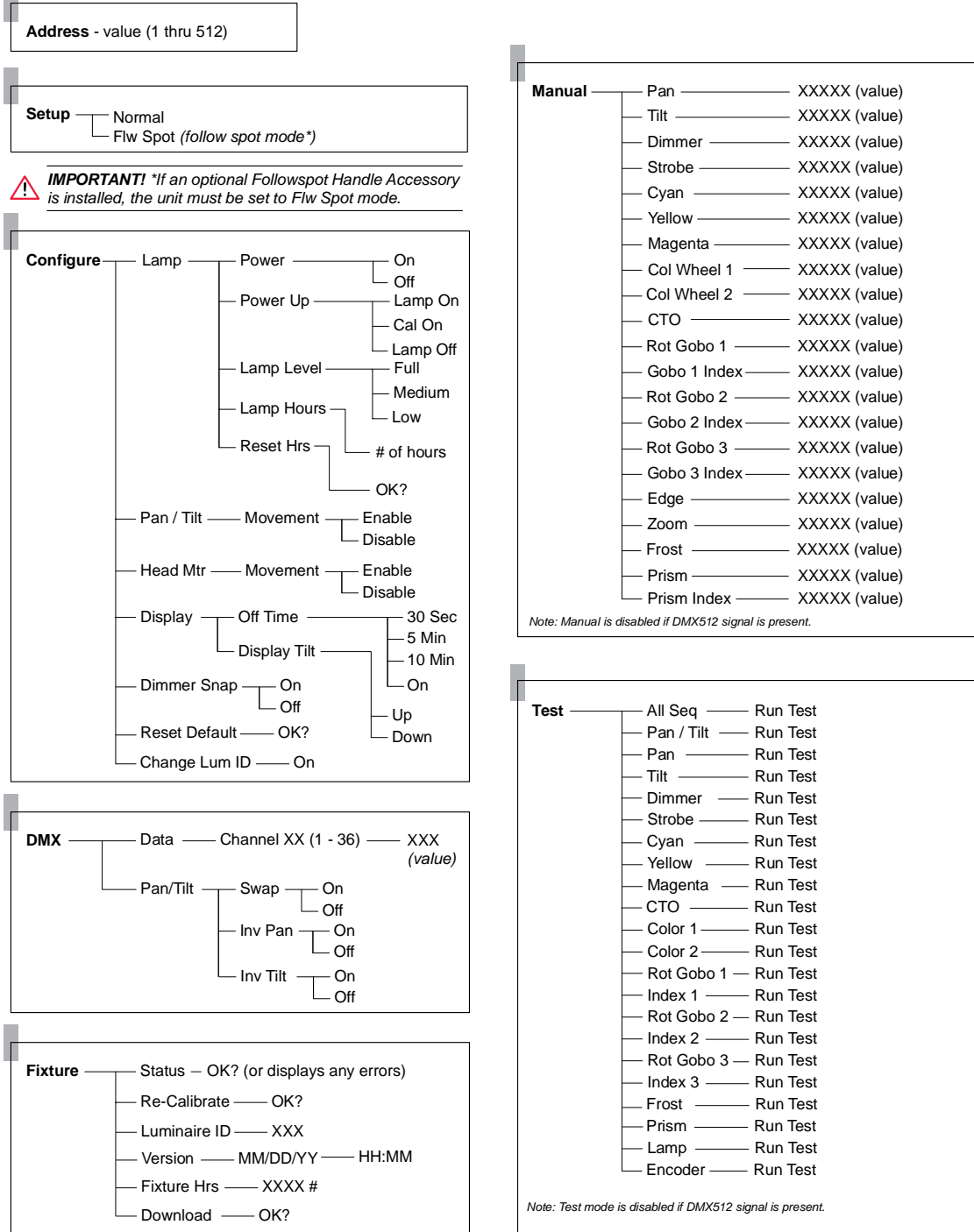

VL3015LT Spot Menu System Function Chart

The following is a detailed look at the internal menu system.

Table 4-1: VL3015LT Spot Menu System Chart

1st Level	2nd Level	3rd Level	4th Level	5thLevel
Address	XXX Address value			
Setup Luminaire Operational Setup	Normal Normal Operational Mode			
	Flw Spot "Follow Spot" Operational Mode			
Configure Configuration	Lamp Lamp Operational Settings and Options	Power Lamp Power	ON	
			OFF (default)	
		Power UP Lamp Power-up State	Lamp On Lamp On	
			Cal ON Lamp On After Calibration	
			Lamp Off Lamp Off	
		Lamp Level Lamp Operational Power Level Setting	Full Full Power Level	
	Medium Medium Power Level			
	Low Lowest Power Level			
	Lamp Hours Lamp Operational Hours	XXXX Cumulative # of Lamp Operation Hours		
	Reset Hrs Reset Lamp Hours	OK?		
	Pan/Tilt Pan and Tilt	Movement Pan and Tilt Movement	Enable Enable	
			Disable Disable	
	Head Mtr Head Motor	Movement Head Movement	Enable Enable	
			Disable Disable	
Display Display Illumination	Off Time Sets display illumination duration	30 Sec OFF in 30 seconds		
		5 Min OFF in 5 minutes		
		10 Min OFF in 10 minutes		
		ON ON indefinitely		
	Display Tilt Sets display orientation in relation to the upper enclosure	Up		
Down				
Dimmer Snap Dimmer Operational Setting	On Dimmer Snap On			
	Off Dimmer Snap Off			
ResetDef Reset Default	OK?			
Chg LumID Change Luminaire ID	XXXX Value			

Table 4-1: VL3015LT Spot Menu System Chart

1st Level	2nd Level	3rd Level	4th Level	5thLevel
DMX <i>DMX Data</i>	DATA	Channel XXX <i>DMX Channel (1 through 36)</i>	XXXX <i>Current DMX Value for selected channel</i>	
	Pan/Tilt <i>Pan and Tilt Options</i>	Swap <i>Swap Pan & Tilt</i>	ON	
			OFF	
		Inv Pan <i>Invert Pan</i>	ON	
			OFF	
		Inv Tilt <i>Invert Tilt</i>	ON	
			OFF	
Fixture	Status <i>Status/Error Display</i>	<i>Scrolls error messages or displays OK</i>		
	Re-Cal <i>Recalibrate</i>	OK? <i>Recalibrate the fixture</i>		
	Luminaire ID <i>Luminaire ID</i>	XXXXXXXX <i>Luminaire ID Number</i>		
	Version <i>Version</i>	MM/DD/YY (Page 1)	HH:MM (Page 2)	
	Fixt Hrs <i>Fixture Hours</i>	XXXX # <i>Hours of Use (non editable)</i>		
	Download <i>Download Software</i>	OK?		
Manual* <i>Manual Commands</i>	Pan	XXX <i>Value</i>		
	Tilt	XXX <i>Value</i>		
	Dimmer	XXX <i>Value</i>		
	Strobe	XXX <i>Value</i>		
	Cyan	XXX <i>Value</i>		
	Yellow	XXX <i>Value</i>		
	Magenta	XXX <i>Value</i>		
	Col Wheel 1 <i>Color Wheel 1</i>	XXX <i>Value</i>		
	Col Wheel 2 <i>Color Wheel 2</i>	XXX <i>Value</i>		
	CTO <i>Color Temperature Orange</i>	XXX <i>Value</i>		
	Rot Gobo1 <i>Rotating Gobo Wheel 1</i>	XXX <i>Value</i>		
	Gobo 1 Index <i>Rotating Gobo Wheel 1 Index</i>	XXX <i>Value</i>		
	Rot Gobo2 <i>Rotating Gobo Wheel 12</i>	XXX <i>Value</i>		
	Gobo 2 Index <i>Rotating Gobo Wheel 2 Index</i>	XXX <i>Value</i>		
	Rot Gobo3 <i>Rotating Gobo Wheel 3</i>	XXX <i>Value</i>		
	Gobo 3 Index <i>Rotating Gobo Wheel 3 Index</i>	XXX <i>Value</i>		
	Edge	XXX <i>Value</i>		
	Zoom	XXX <i>Value</i>		
	Frost	XXX <i>Value</i>		
	Prism	XXX <i>Value</i>		
Prism Index	XXX <i>Value</i>			

Table 4-1: VL3015LT Spot Menu System Chart

1st Level	2nd Level	3rd Level	4th Level	5thLevel
Test	All Seq <i>Test All mechanisms - sequence through each mechanism</i>	RUN TEST <i>Run-Test in Progress</i>	Press [Menu] to stop tests	
	Pan/Tilt	RUN TEST <i>Run-Test in Progress</i>		
	Pan	RUN TEST <i>Run-Test in Progress</i>		
	Tilt	RUN TEST <i>Run-Test in Progress</i>		
	Dimmer	RUN TEST <i>Run-Test in Progress</i>		
	Strobe	RUN TEST <i>Run-Test in Progress</i>		
	Cyan	RUN TEST <i>Run-Test in Progress</i>		
	Yellow	RUN TEST <i>Run-Test in Progress</i>		
	Magenta	RUN TEST <i>Run-Test in Progress</i>		
	CTO	RUN TEST <i>Run-Test in Progress</i>		
	Color 1 <i>Color Wheel 1</i>	RUN TEST <i>Run-Test in Progress</i>		
	Color 2 <i>Color Wheel 2</i>	RUN TEST <i>Run-Test in Progress</i>		
	RotGobo1	RUN TEST <i>Run-Test in Progress</i>		
	GobIndx1	RUN TEST <i>Run-Test in Progress</i>		
	RotGobo2	RUN TEST <i>Run-Test in Progress</i>		
	GobIndx2	RUN TEST <i>Run-Test in Progress</i>		
	RotGobo3	RUN TEST <i>Run-Test in Progress</i>		
	GobIndx3	RUN TEST <i>Run-Test in Progress</i>		
	Frost	RUN TEST <i>Run-Test in Progress</i>		
	Prism	RUN TEST <i>Run-Test in Progress</i>		
Lamp <i>Disables Pan/Tilt and executes Home position.</i>	RUN TEST <i>Run-Test in Progress</i>			
Encoder	RUN TEST <i>Run-Test in Progress</i>			

* For 16-bit parameters, the data displayed will be scaled to a range of 0-4095.

Menu Function Definitions

For easy reference, each possible menu item is listed alphabetically in the first column by its display abbreviation. The second column follows with a definition of the abbreviation and then a third column provides an explanation of its purpose and function.

Table 4-2: Menu Function Definitions

Display	Definition	Purpose
10 Min	10 Minutes	Sets Menu Display to automatically shut off after 10 minutes of non-use.
30 Sec	30 Seconds	Sets Menu Display to automatically shut off after 30 seconds of non-use.
5 Min	5 Minutes	Sets Menu Display to automatically shut off after 5 minutes of non-use.
Address	Address	Accesses option for setting luminaire DMX starting address.
All SEQ	All Sequence	Tests all internal mechanisms in sequence for X steps.
Cyan	Cyan	Specifies cyan color parameter for manual control (Manual) or testing (Test).
Cal ON	Calibration On	Configures arc luminaire so that lamp will strike after calibration.
Chan XXX	DMX Channel	Specifies DMX channel for display of current data value.
Chg LumID	Change Luminaire ID	To set luminaire identification number
ColrMix	Color Mixer	Specifies color mixing mechanism for testing (Test).
Col Wheel #	Color Wheel	Specifies color wheel (1 or 2) for manual control (Manual) or testing (Test).
Config	System Configuration	Accesses options for setting lamp, pan/tilt, and Menu Display defaults. Also accesses lamp information such as number of hours used, along with its respective reset function.
CTO	CTO Function	Specifies CTO (color temperature orange) parameter for manual control (Manual) or testing (Test).
Data	DMX Data	Accesses option for setting DMX address channel.
Dimmer	Dimmer	Specifies dimmer mechanism for manual control (Manual) or testing (Test).
Dimmer Snap	Dimmer Snap Operation	Specifies dimmer mechanism for either normal or snap modes.
Disable	Disable	Disables a function.
Display	Display	Accesses options for Menu Display illumination defaults.
DMX	DMX	Accesses options for DMX system settings.
Download	Download	Initiates download of luminaire software.
Edge	Edge	Specifies edge function for manual control (Manual) or testing (Test).
Enable	Enable	Enables a function.
Encoder	Encoder	Accesses pan/tilt encoders for diagnostic testing.
FAIL	Test Fail	Indicates that a test has failed.
FixGobo	Gobo Wheel 1	Specifies gobo wheel 1 (rotating gobo wheel) for manual control (Manual) and testing (Test)
Fixt Hrs	Fixture Hours	Displays total number of hours luminaire has been powered on.
Fixture	Fixture	Accesses luminaire information such as serial number, software version, and total operation hours. Also accesses recalibration and download options.
Flw Spot	Follow Spot	Sets the luminaire to follow spot operational mode where the pan and tilt are disabled (not controllable by DMX commands). Focus, zoom, gobo/effects, and color are still controllable by DMX.
Frost	Frost Mechanism	Specifies frost function for manual control (Manual) or testing (Test).
Head Mtr	Head Motor	Configures head movement options.
Inv Pan	Invert Pan	Reverses pan action for special focus requirements.
Inv Tilt	Invert Tilt	Reverses tilt action for special focus requirements.

Table 4-2: Menu Function Definitions (Continued)

Display	Definition	Purpose
Lamp	Lamp	Accesses lamp power-up options, reset and information (Config) or presets the Zoom and Edge to a specific setting for Lamp adjustment (Test).
Lamp OFF	Lamp is Off	Configures arc luminaire so that lamp will not strike upon power up. (<i>Default setting</i>)
Lamp ON	Lamp is On	Configures arc luminaire so that lamp will strike upon power up.
LampHour	Lamp Hours	Displays total number of lamp operating hours.
Lum Id	Luminaire ID	Displays unique luminaire ID number.
Magenta	Magenta	Specifies magenta parameter for manual control (Manual) or testing (Test).
Manual	Manual	Accesses options for luminaire mechanism control by entry of data values.
Movement	Movement	Enables or disables pan and tilt movement.
OFF	Off	Turns off a function.
OK	Okay	Indicates calibration has completed and no errors have occurred.
OK?	Okay?	Prompt for pressing [Enter] before an action is executed.
ON	On Indefinitely	Sets Menu Display to stay on until programmed otherwise (Display) or turns on a function.
Pan	Pan	Specifies pan function for manual control (Manual) or testing (Test).
Pan/Tilt	Pan/Tilt	Accesses pan and tilt options for focus swap function, movement enable/disable, manual control and testing.
PASS	Test Pass	Indicates that a test has passed.
Power	Lamp Power	Accesses options to adjust lamp power setting.
Power Up	Power Up	Accesses options for lamp power up state.
Prism	Prism Mechanism	Specifies prism parameter for manual control (Manual) or testing (Test).
Prism Index	Prism Index	Specifies prism parameter for manual control (Manual).
Program	Programming	Currently programming the new version of software.
Re-Cal	Recalibrate	Recalibrates luminaire.
ResetDef	Reset Defaults	Resets default system configuration values.
ResetLmp	Reset Lamp	Resets lamp hour and strike counters. (For use when new lamp is installed.)
Rot Index #	Gobo Index #	Specifies rotating the gobo index for manual control (Manual) and testing (Test) (EOT sensor, etc.) for each rotating gobo wheel assembly (1 through 3)
Rot Gobo #	Gobo Wheel #	Specifies rotating gobo wheel for manual control (Manual) and testing (Test) for each rotating gobo wheel assembly (1 through 3)
RUN TEST	Run Test	Indicates that a mechanism test is in progress.
Sensor	Sensors	Accesses sensor types for diagnostic testing.
Setup	Setup	Accesses unit model type options (do not change).
Status	Status/Error	Allows scrolling through error list or displays OK if no errors.
Strobe	Strobe	Specifies strobe function for manual control (Manual) or testing (Test).
STST	Sensor Test	Indicates that a system sensor test is in progress.
Swap	Swap	Swaps pan/tilt action for special focus requirements.
Test	Test	Accesses diagnostic tests for internal mechanisms.
Tilt	Tilt	Specifies tilt function for manual control (Manual) or testing (Test).
Version	Version	Displays current software version date and time (in two pages).
Yellow	Yellow	Specifies yellow color parameter for manual control (Manual) or testing (Test).
Zoom	Zoom Function	Specifies zoom function for manual control (Manual) or testing (Test).

Self-Tests

Running Parameter Tests

The luminaire is capable of running self-tests by using the **Test** menu functions.

When running tests on multiple luminaires, a DMX termination connector is required at the last luminaire in the link. Refer to [“Connecting Data and Power” on page 18](#) for more information regarding the construction of this connector.

Note: After 10 seconds of inactivity, the menu display will change to the default state showing the address.

To connect luminaires for simultaneous testing:

- Step 1. At last luminaire, install a DMX termination connector into DATA THRU XLR connector.
- Step 2. At master luminaire Menu Display, press [Menu].

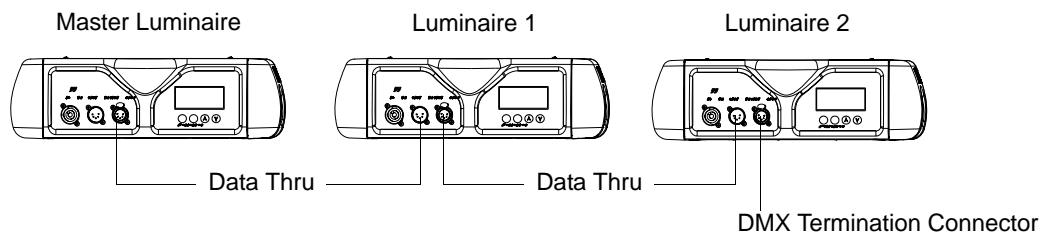

Figure 4-2: Testing Setup

To run tests:

- Step 1. Press [Menu].
- Step 2. Press [Up] / [Down] arrows until **Test** appears. Press [Enter].
- Step 3. Use [Up] / [Down] arrows to select a parameter to test. Refer to [“VL3015LT Spot Menu System Function Chart” on page 51](#) for a complete list of test parameters which can be chosen.
- Step 4. Press [Enter] to run test.
- Step 5. Press [Menu] to stop test at any time.

Movement Disable

The Movement option allows pan and tilt to be disabled so that the luminaire can be placed in any position for testing without movement occurring. In order to regain full control of the luminaire, Movement will need to be enabled after testing.

Note: When using the Movement option, pan and tilt will be disabled for all the luminaires that are linked.



WARNING: If the Followspot Handle accessory is installed, you must use the FLW Spot (Follow Spot Operational Mode) setting in Setup menu. Movement Disable is temporary setting and is not retained when power is disengaged from the fixture. The FLW Spot setting is retained when power is disengaged until changed in the menu setting by the user.

To set movement option:

- Step 1. Press [Menu].
- Step 2. Press [Up] / [Down] arrows until Config appears. Press [Enter].
- Step 3. Press [Up] / [Down] arrows until Pan/Tilt appears. Press [Enter].
- Step 4. Movement will be displayed. Press [Enter].
- Step 5. Use [Up] / [Down] arrows to select Enable or Disable. Press [Enter] to select.

Notes

APPENDIX A.

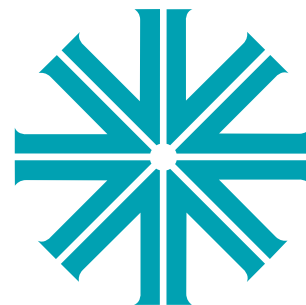

Luminaire Care and Routine Maintenance

This appendix provides instructions for troubleshooting and routine maintenance which may be necessary during the life of the luminaire.

- **Equipment Handling**
- **Troubleshooting**
- **Routine Maintenance**



WARNING: All maintenance procedures are to be performed with power removed from the luminaire. Never remove covers or backcap while lamp is in operation.

Equipment Handling

Below are some basic tips and information on handling luminaires and their associated components.

Locations/Use



VARI*LITE luminaires are designed for dry locations only. Exposure to rain or moisture (including, but not limited to, fog machines, misters, etc.) may damage luminaire.

Lamps

Servicing

- When handling a lamp, hold it by the ceramic base while wearing cotton gloves or finger cots. Do not touch the glass envelope (bulb). If you touch the glass with bare fingers, immediately wipe off any fingerprints with isopropyl alcohol.
- Use care when opening and closing the rear castings (or covers) of luminaires and cleaning reflectors. Any jarring can undo the optical alignment of the lamp.

Heat

When lamps are lit, the interior of the luminaires becomes very hot. To aid in the airflow circulation within the luminaires, after dousing the lamps, wait ten minutes before removing power to the luminaires. This will provide enough time for the equipment fan to cool off the unit. Users should wait until the unit is cool to the touch before servicing or handling.

Lamp Life

- When operating arc lamps, allow luminaires to operate for at least 3 minutes. It takes about 3 minutes for the fill components (mercury and halogen-metal compounds) in the lamp tubes to vaporize completely. If the lamps are switched off earlier than 3 minutes, the fill components are partially vaporized. The inadequately vaporized fill components and the electrode material (tungsten) are deposited in the areas of the lamp tubes that have remained cool. As a result, the lamp tubes blacken prematurely and reduce the service life of the lamps.
- If system will be unattended for more than two hours, luminaire lamps should be doused. Standby mode should not be used for more than two hours.
- When the lamp is struck, the luminaire should be maintained in a horizontal position when not in use.
- For arc lamp luminaires, heads should be tilted horizontal before starting lamps. Lamps generate light by an electrical discharge arc, whereby the electrons from two electrodes excite the fill components to give off light. Because of the alternating current “position”, the electrons are alternately given off by the two electrodes. When a lamp is set in a vertical position, the halogen-metal compounds, which determine the color temperature of the lamp, collect at the top end of the glass envelope. When the lamp is started, color deviations occur since the concentration of halogen

compounds is greater around the top electrode than the bottom electrode. In addition, the fill components that are difficult to vaporize congeal around the bottom electrode, thereby reducing lamp life.

Solid State Electronics



Electrostatic Discharge (ESD)

Electrostatic discharge (ESD) presents a significant danger to solid state electronic components (semiconductor devices and PC board assemblies). Static electricity can build on a variety of common objects (including people) simply by handling or moving. ESD rarely results in immediate failure of a component, but shows up later as an intermittent problem or severely reduces the life of the component. All VARI*LITE equipment uses solid state electronics and appropriate precautions to protect them should be observed when servicing.

Printed Circuit Boards (PCBs)

All PC boards should be shipped in electrostatic shielding bags. When handling PC boards or components, devices such as conductive mats and conductive wrist straps should be used whenever possible. If these precautionary devices are not available, handling of PC boards and components should be avoided.



CAUTION: Black foam (used to package solid state electronics) should never be used for packing batteries or put in contact with PC boards which contain batteries.

Troubleshooting

Error Messages

If a problem occurs during luminaire calibration, at the end of the calibration sequence the Menu Display will cycle through any applicable error message(s) until the end of the list is reached. To review the error messages again, it will be necessary to access them using the **Status** function.

To access error messages:

- Step 1. Press [Menu].
- Step 2. Press [Up] / [Down] arrows until **Fixture** appears. Press [Enter].
- Step 3. Press [Up]/ [Down] arrows to access **Status**. Press [Enter]. (Display will now scroll through any error messages or display OK if no errors.)

Table A-1: Error Messages

Display	Message
OK	No Errors Found
Pan/No Sens	Pan sensor not found.
Pan/Encoder/Fail	Pan encoder failure.
Tilt/No Sens	Tilt sensor not found.
Tilt/Encoder/Fail	Tilt encoder failure.
Index1/No Sens	Gobo 1 Index sensor not found.
RotGobo1/No Sens	Rotating Gobo wheel 1 sensor not found.
Index2/No Sens	Gobo 2 Index sensor not found.
RotGobo2/No Sens	Rotating Gobo wheel 2 sensor not found.
Index3/No Sens	Gobo 3 Index sensor not found.
RotGobo3/No Sens	Rotating Gobo wheel 3 sensor not found.
Dimmer/No Sens	Dimmer sensor not found.
Cyan/No Sens	Cyan sensor not found.
Yellow/No Sens	Yellow sensor not found.
Magenta/No Sens	Magenta sensor not found.
ColWheel1/No Sens	Color wheel 1 sensor not found.
ColWheel2/No Sens	Color wheel 2 sensor not found.
CTO/No Sens	CTO sensor not found.
Zoom/No Sens	Zoom sensor not found.
Edge/No Sens	Edge sensor not found.
Frost/No Sens	Frost sensor not found.
Prism/No Sens	Prism sensor not found.

Troubleshooting Guide

If a problem is suspected, first try recalibrating the luminaire to prompt an error message. The chart below provides possible causes and remedies for various error messages and/or symptoms.

Table A-2: Troubleshooting Chart

Message	Symptom	Description	Possible Cause/Remedy
Lamp Power Douse	Lamp does not strike upon start-up	Lamp Off option is configured (<i>note, Lamp Off is default from factory</i>)	- Reconfigure lamp startup option in Lamp config menu.
n/a	Lamp douses frequently	Lamp Douse	Fan failure... - check fans for proper connection and operation.
n/a	Lamp will not strike	Lamp Strike Failure	Lamp cutout switch engaged... - check lamp cutout switches at lamp box and fan ducts. Bad lamp... - replace lamp. Low input voltage... - check input power (must be 200 to 264 VAC).
n/a	Luminaire behaves oddly	Profile Not Matched	Profile not set correctly... - confirm console patch matches fixture DMX address. - confirm DMX protocol matches console profile.
n/a	Luminaire does not power up	No power	Switch not turned on... - verify switch is turned on. Not plugged in... - ensure A/C cable is connected to power source.
n/a	Self tests will not run or software download does not work.	DMX Data Input	Detecting DMX data... - disconnect DMX input cable.
n/a	No response to DMX data	DMX Failure	MCB connector disconnected... - check MCB DATA IN connection.
n/a	Erratic control of luminaire	DMX Termination	No DMX termination or termination not correct... - check for DMX terminator.
n/a	No control of pan or tilt movement from DMX (console) commands	Pan/Tilt do not respond to DMX	Pan/Tilt do not respond to DMX... - Turn off Followspot Mode in Setup menu. (<i>Ensure that Followspot handle accessories are not installed!</i>) - Pan/Tilt transport locks need to be disengaged.
n/a	Cannot edge on gobo image	Sharp image cannot be obtained	Gobo edge image is not sharp... - Adjust the Range channel to fine tune the edge setting. See “Range” on page 30 for more information.

Routine Maintenance

Lamp Replacement



WARNING: Ensure that power is removed from luminaire when installing lamp.



CAUTION: Wear cotton gloves or other covering while installing lamp. Touching lamp glass with bare fingers will leave oil and may cause the lamp to explode or reduce lamp life. If touched, use alcohol and cotton cloth to thoroughly clean glass portion of lamp.

To replace lamp:

- Step 1. Ensure power is removed from luminaire.
- Step 2. At rear of luminaire head, loosen four 1/4-turn screws and slide lamp box back and out (it is hinged).
- Step 3. One side at a time, press lamp lock lever forward and remove current lamp.
- Step 4. Position new lamp with dimple side down. One side at a time, press lamp lock lever forward and insert lamp connector. Ensure lamp is seated fully in place.
- Step 5. Close lamp box and re-tighten 1/4-turn screws.
- Step 6. Align lamp as detailed in [“Align Lamp” on page 65](#).



CAUTION: Allow lamp to cool before servicing.



CAUTION: Do not touch lamp or reflector with bare fingers.

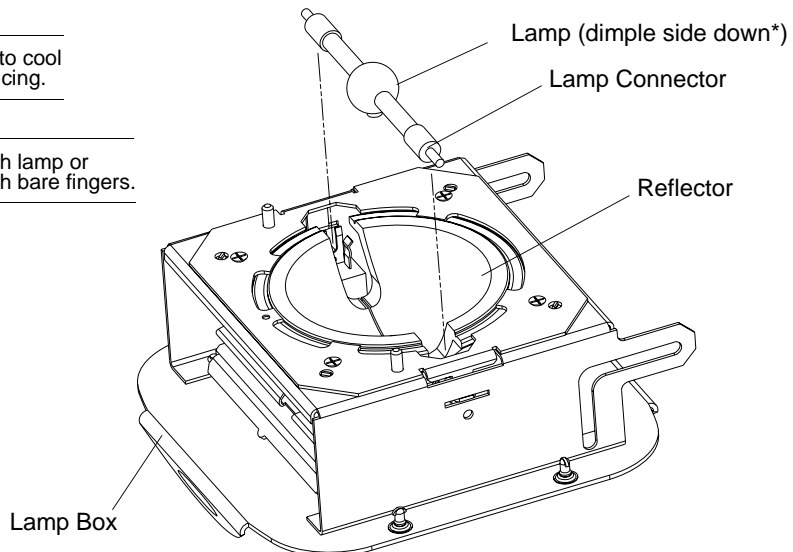

NOTE: *Dimple, on lamp, towards reflector.

Luminaire Head Not Shown For Clarity

Figure A-1: Installing Lamp

Align Lamp

The design of the VL3015LT Spot Luminaire optical system allows for a flat or peaked field. A flat field is one where there is no detectable hot spot and a peaked field is one where the intensity of the beam is greater at the center of the beam than at the perimeter.

After a new lamp is installed, it will be necessary to align the lamp to optimize the beam. Knobs located at the luminaire's backcap will allow adjustment.



WARNING: Backcap and adjustment knobs will be HOT during lamp operation. Wear gloves to prevent burns.

To align lamp:

- Step 1. Power-up luminaire.
- Step 2. At Menu Display, select Lamp from Config menu (refer to “[VL3015LT Spot Menu System Overview](#)” on page 50). (If using console, set intensity to 100%, open beam size iris and focus for hard edge.)
- Step 3. Position beam on a white wall at a distance of 10 to 20 feet.
- Step 4. At backcap, using X, Y and Z adjustment knobs, adjust beam as required.

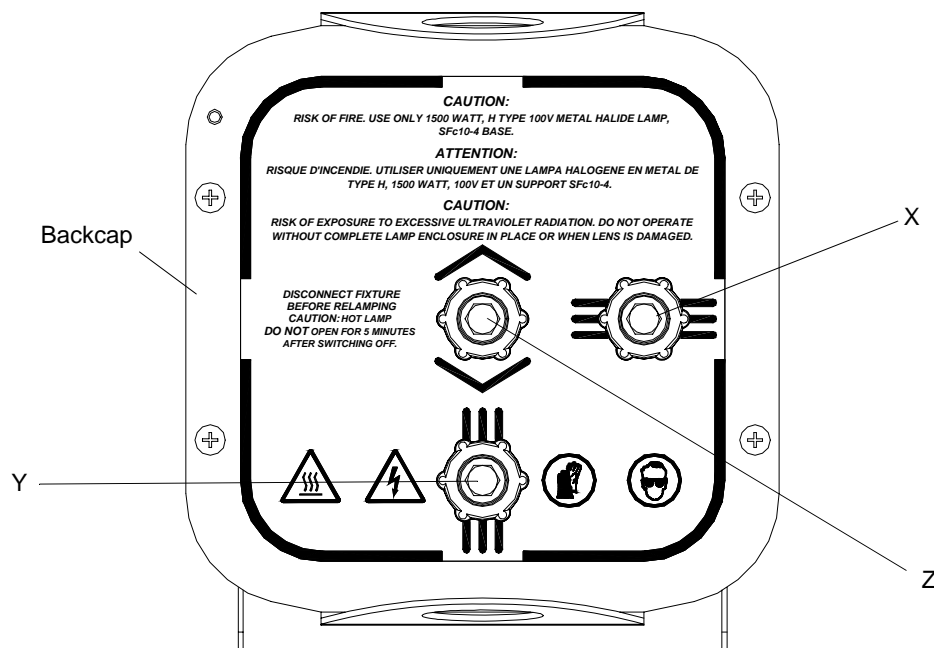

Figure A-2: Aligning Lamp - Lamp Alignment Knobs

Gobo Replacement - Gobo Wheels

Tools:

#2 Phillips screwdriver

Overview of Gobos and Gags used in VL3015LT Spot Luminaire

Due to the immense energy and light produced by VL3015LT spot luminaires, Vari-Lite recommends to users and owners of this fixture follow the guidelines outlined below when loading gobos or gags in any of the three rotating gobo wheels.

Gobo / Gag Use and Positioning

Vari-Lite has purposely selected a set of standard gobos and gags for this fixture and positioned them within the fixture to offer optimum versatility / performance. The gobos supplied - in the standard factory configuration - have been tested in their respective original positions to protect their service life (including when morphed between wheels 1 and 3).

Note: For standard factory gobo / gag loads and position, please refer to [“VL3015LT Spot Gobo/ Effects Control” on page 30](#) of this manual.

Users can load their own patterns (gobos or gags). When using custom gobos or gags, Vari-Lite recommends the following guidelines:

- When morphing gobos, gobos should be morphed between wheels 1 and 3 only, never in wheel 2.
- Rotating gobo wheel 2 has been designated the gag (effects) wheel. Wheel 2 should only house clear type gags or gobos that permit minimum unabated light transmission.
- Under no circumstances should owners or users use or install metal gobos. Using metal gobos in the VL3015LT spot luminaire will void the fixture's warranty.



Note: Vari-Lite cannot guarantee the service life of any custom gobos or gags when used in conjunction with this fixture. Owners and users employing custom gobos and gags do so at their own risk.

To Install or Replace Gobos



WARNING: Remove power from luminaire before performing maintenance. Gobos may be HOT after operation. Allow to cool before replacing.

To replace a rotating gobo:

- Step 1. Remove power from luminaire.
- Step 2. As illustrated in [Figure A-3](#), remove top and/or bottom head cover by loosening four 1/4-turn screws to access the three gobos wheels.

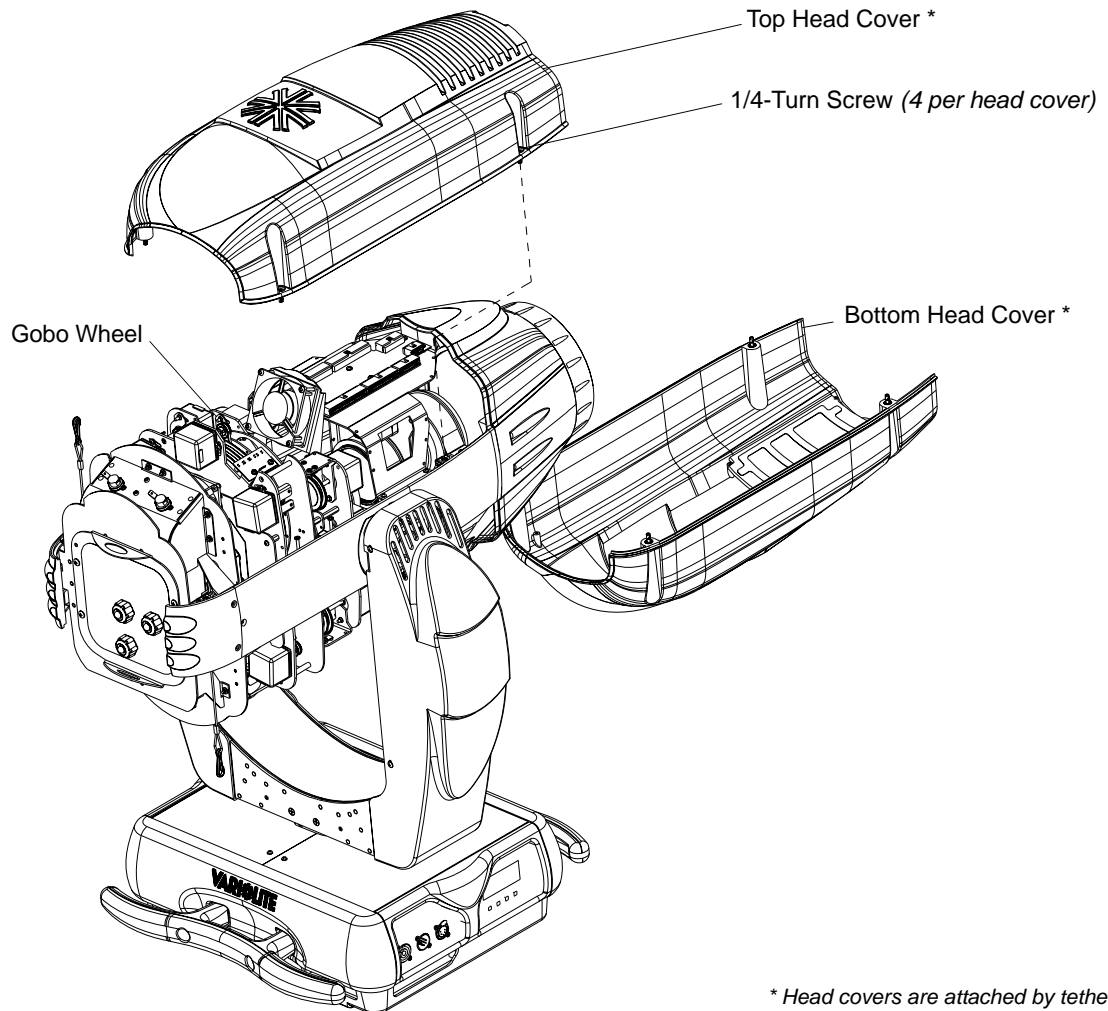

Figure A-3: Head Covers - Removal

- Step 3. If removing gobos via bottom of head assembly, undo fan tray assembly with thumb screw to access.
- Step 4. Rotate desired gobo wheel until required gobo position is accessible.



CAUTION: Do not push on gobo glass. Press on gobo carrier only.



CAUTION: Do not touch gobos with bare fingers. Wear cotton gloves or other covering while replacing. To clean, refer to [“Cleaning Optics, Filters and Gobos”](#) on page 71.

- Step 5. Remove current gobo by carefully pressing on edges of gobo carrier with fingers, pressing gobo toward front end of luminaire (toward lens), and out of wheel.



CAUTION:

Do not touch glass with bare fingers.
Press on gobo carrier only.

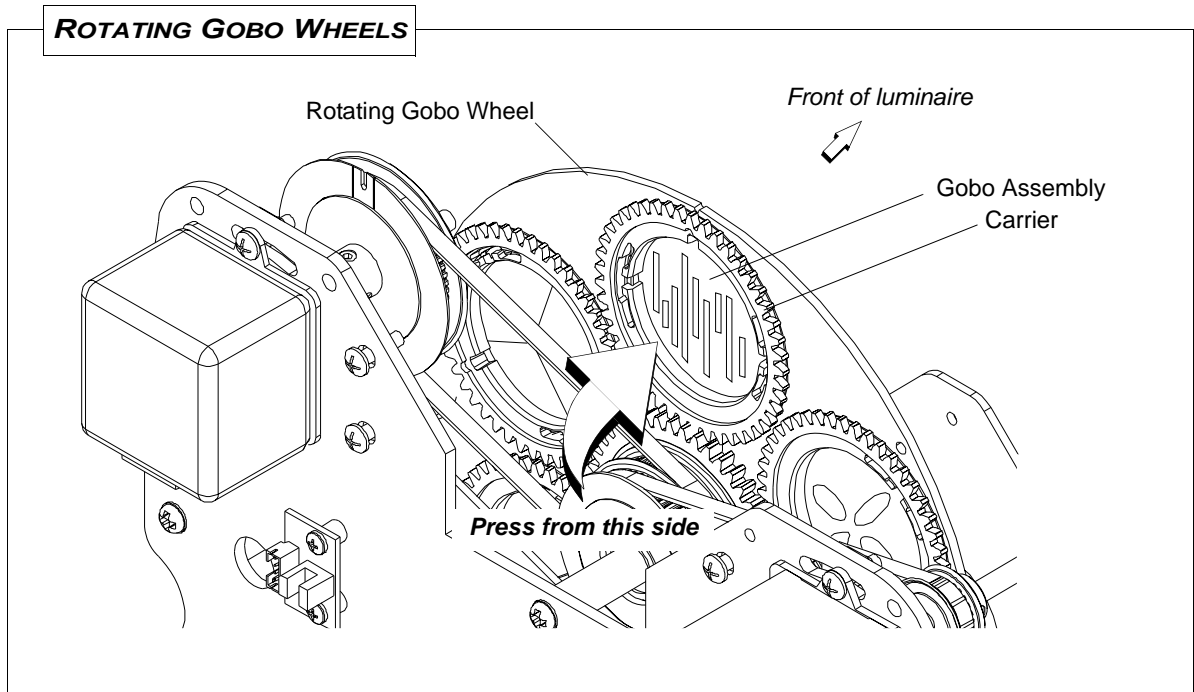

Figure A-4: Replacing Gobos

- Step 6. Install new gobo as follows:
- Align three tabs on gobo carrier with three notches in wheel (gobo can only be oriented in one direction).
 - Insert gobo carrier into wheel, ensuring that carrier snaps into place.
- Step 7. Replace cover(s).

Fixed Color Filter Replacement

Tools:

#2 Phillips screwdriver



WARNING: Remove power from luminaire before performing maintenance. Filters may be HOT after operation. Allow to cool before replacing.

To replace a fixed color filter on Color Wheel 1 (closest to the lamp):

- Step 1. Remove power from luminaire.
- Step 2. Remove bottom (relative to backcap label) head cover by loosening the four 1/4-turn screws.
- Step 3. Undo fan tray assembly with thumb screw to access filters.



CAUTION: Do not touch filters with bare fingers. Wear cotton gloves or other covering while replacing filters. To clean filters, use isopropyl alcohol and soft cloth. Strong cleaning solutions can damage coating. Fingerprints or other grease deposits on filters can cause the glass to break.

- Step 4. As shown in [Figure A-5](#), rotate Color Wheel 1 until the filter you are changing is accessible.
- Step 5. To improve access to the filter, rotate the mixed color wheels to position the cut-outs next to the filter you are changing.
- Step 6. Gently press the color filter toward the lamp until it is free of the lock pins. Remove filter.
- Step 7. Orienting coated side of filter towards lamp, slide new filter under the spring clip until it is securely retained by the lock pins.
- Step 8. Replace the head cover.

To replace a fixed color filter on Color Wheel 2 (closest to the lens assembly):

- Step 1. Remove power from luminaire.
- Step 2. Remove top (relative to backcap label) head cover by loosening the four 1/4-turn screws.



CAUTION: Do not touch filters with bare fingers. Wear cotton gloves or other covering while replacing filters. To clean filters, use isopropyl alcohol and soft cloth. Strong cleaning solutions can damage coating. Fingerprints or other grease deposits on filters can cause the glass to break.

- Step 3. Rotate Color Wheel 2 until the filter you are changing is accessible.
- Step 4. To improve access to the filter, rotate the mixed color wheels to position the cut-outs next to the filter you are changing.
- Step 5. As shown in [Figure A-5](#), gently press the color filter toward the lens until it is free of the lock pins. Remove the filter.

Fixed Color Filter Replacement (continued)

- Step 6. Orienting coated side of filter towards lamp, slide new filter under the spring clip until it is securely retained by the lock pins.
- Step 7. Replace the head cover.

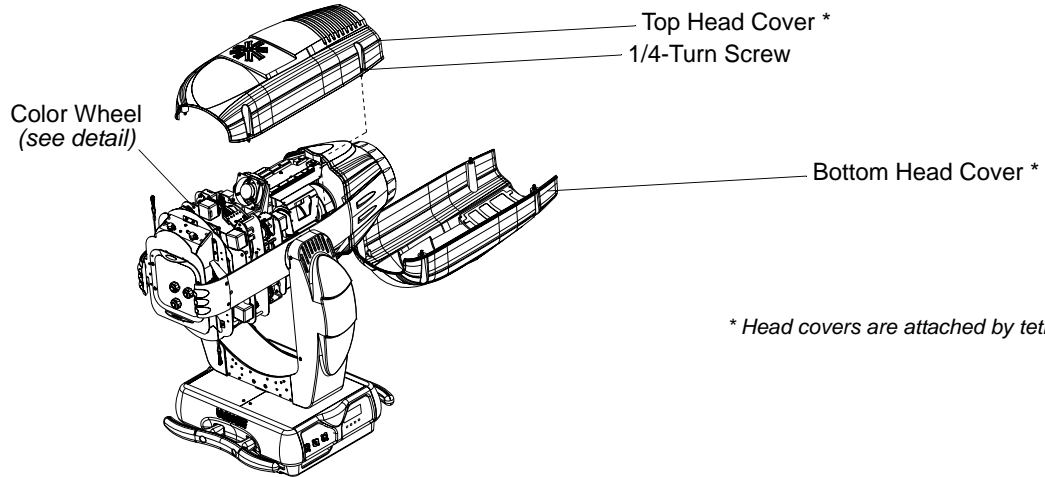

* Head covers are attached by tethers.

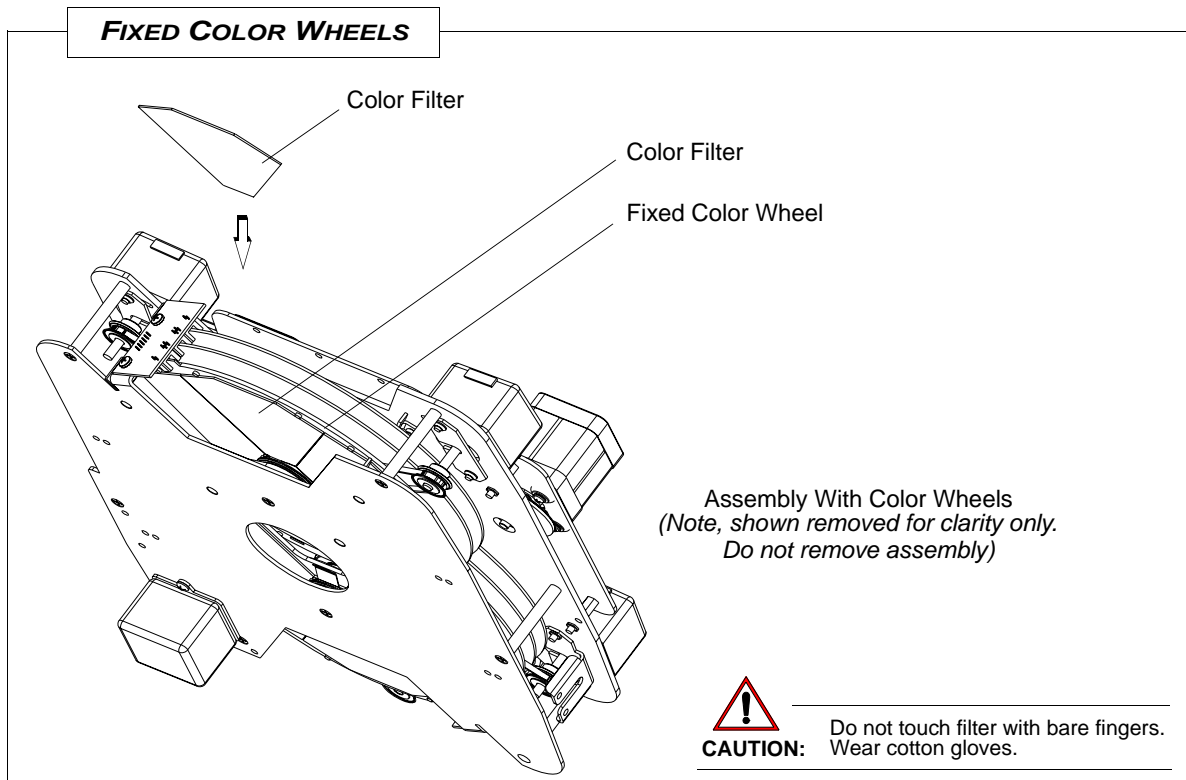

Figure A-5: Replacing a Color Filter

Cleaning Optics, Filters and Gobos



WARNING: Remove power from luminaire before performing maintenance.



WARNING: Acetone is a harsh cleaning agent and solvent. Acetone is very flammable. Please handle acetone according to manufacturer's safety instructions and precautions.

The front lens, optics/color filters, and reflector may require cleaning after extended use.

- **FRONT LENS:** Use a isopropyl alcohol with a soft, lint-free cloth to clean the front lens.
- **OPTICS/COLOR FILTERS/ GOBOS:** Use Acetone or Isopropyl Alcohol along with a soft, lint-free cloth to clean the optics/color filters.
- **REFLECTOR:** Use Acetone or Isopropyl Alcohol along with a soft, lint-free cloth to clean the reflector.



CAUTION: Do not continuously rub color filters or reflector - it may damage or remove the optical coating.

Followspot Handle Accessory Installation (Optional)

The VL3015LT Spot Luminaire is an optional accessory available and sold through your Authorized VARI*LITE Dealer. This accessory is designed to allow the VL3015LT Spot Luminaire (Vari-Lite part number 21.9698.9610) to be utilized as a manually aimed followspot while still providing full attribute controls via DMX.

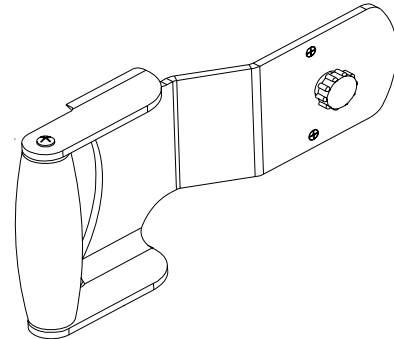

VL3015LT Spot Luminaire Followspot Handle Accessory

Warnings



- When VL3015LT Spot Luminaire is installed, the luminaire cannot be operated in its normal mode (pan and tilt controlled via DMX512) or damage to luminaire may occur.
- When operating the VL3015LT luminaire with the VL3015LT Spot Luminaire, operators must be aware of the intense heat generated at the back of luminaire and wear appropriate hand protection.
- Ensure that power is completely removed from luminaire when installing this accessory.
- Allow luminaire to completely cool before performing the installation procedure contained herein.

Luminaire Configuration



WARNING: Before installing the VL3015LT Spot Luminaire or handles, you must configure the Luminaire, through the menu system, for followspot operational mode as follows:

- Step 1. Make sure that luminaire is powered and DMX control cables are REMOVED from luminaire.
- Step 2. At menu, disable pan and tilt motors as follows: **Setup > Followspot > Enable.**
- Step 3. After configuration setting is complete, you must remove power from luminaire to install handle(s).

Installation

To install the Followspot Handle Accessory on a VL3015LT Spot Luminaire:



WARNING: Completely remove all power from luminaire before performing the procedure described herein. The luminaire head may be HOT after operation. Allow to cool before proceeding.

- Step 1. Completely disconnect and remove all power from luminaire.



Note: [Figure A-6](#) and [Figure A-7](#) (on [page 73](#)) illustrate handle installation on the right side of the luminaire. The VL3015LT Spot Luminaire can be installed on either side. Installation instructions are the same for either installation method. Up to two handles may be installed on a luminaire.

- Step 2. As shown in [Figure A-6](#), at desired side of luminaire, remove indicated screw from back portion of side rail. Keep screw in a safe place for later use (if handle is removed and luminaire placed back into normal operational service).

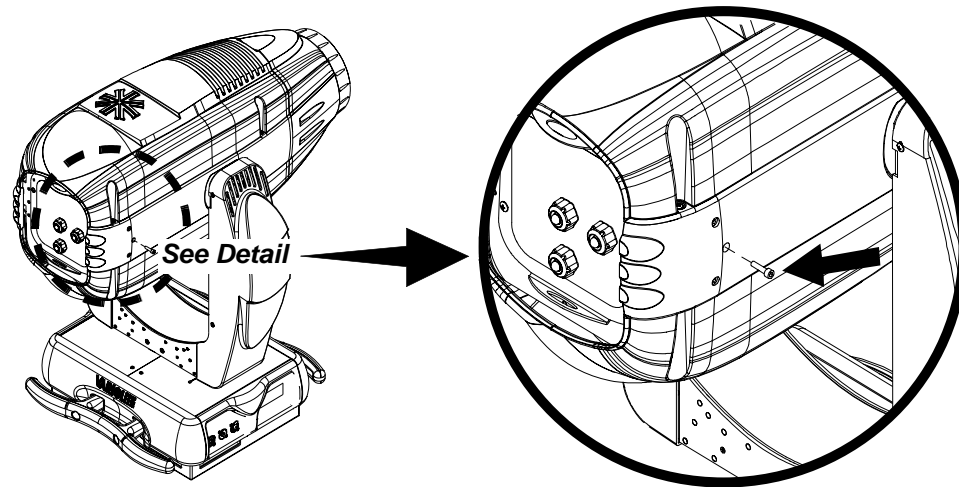

Figure A-6: Rear Rail Screw Removal

- Step 3. As shown in [Figure A-7](#), at desired side of Luminaire, position VL3015LT Spot Luminaire where retaining screw is inline with screw hole (where screw was removed in previous step).

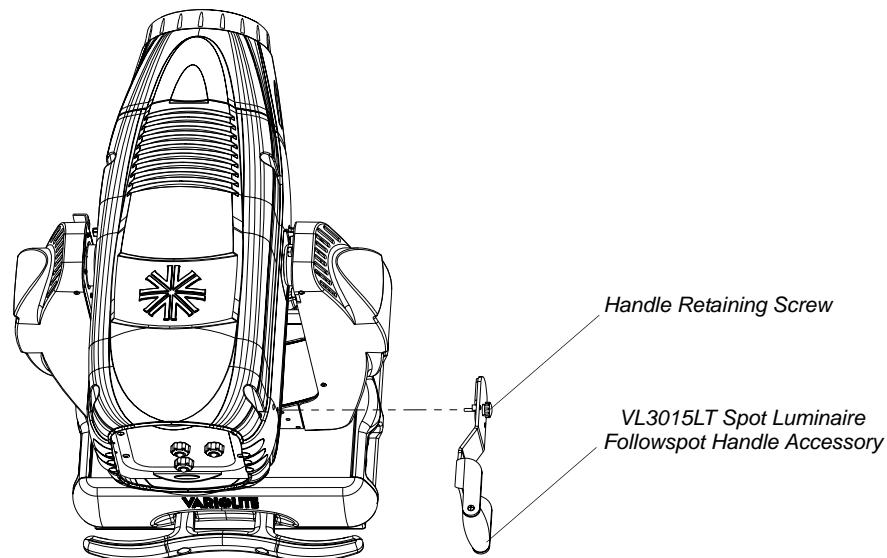

Figure A-7: VL3015LT Spot Luminaire Installation

- Step 4. Carefully thread retaining screw into screw hole. Note, the two installed screws (on the handle) should align with the two holes above and below screw hole. Hand-tighten handle retaining screw. **DO NOT OVER TIGHTEN!**



WARNING: After installing the VL3015LT Spot Luminaire or handles, the luminaire, must always be set (through the menu system) for followspot operational mode or damage to the luminaire will occur! Refer to [“VL3015LT Spot Menu System Overview”](#) on page 50 for more information.

Notes

APPENDIX B.

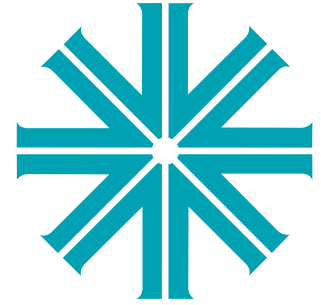

Technical Specifications

VL3015LT Spot Luminaire



PROGRAMMABLE FUNCTIONS

Color System

Six color control wheels total. A three filter CMY cross fading system, two fixed color wheels with five interchangeable color filters each capable of continuous wheel rotation for additional effects, and a variable CTO color temperature correction wheel.

Zoom Optics

A 13-element 10:1 zoom optics system, covering a range from 6° to 60°.

Beam Size Control

A mechanical iris provides continuous beam size control for rapid and smooth timed beam angle changes.

Intensity Control

Full field dimming designed for smooth timed fades as well as quick dimming effects.

Strobe

High-performance dual blade strobe system capable of ultra-fast operation.

Rotating Gobo Wheels

Three gobo/effects wheels combine to each offer four rotatable, indexable gobo positions and one open position.

Edge and Pattern Focus

Variable beam focus to soften edges of gobos or spots. Remarkable depth of field capability allows morphing effects between all pattern and effects wheels.

Variable Frost

Independent, drop-in armature that holds variable frost glass.

Rotating Prism

Independent, drop-in armature which rotates and holds a 3-facet prism.

Pan and Tilt

Smooth, time-controlled continuous motion by way of three-phase stepper motor systems.

Pan and Tilt Range

Pan - 540°, Tilt - 270° (Accuracy: 0.3° resolution)





OPTICAL

Source

Triple wattage, double-ended lamp. The lamp is capable of operation at 900W, 1200W or 1650W - mode selectable from fixture or console.

Color Temperature

6000K at 1650W and 6300K at 900W and 1200W

Output

41,487 lumens

Reflector

Precision glass reflector with dichroic cold mirror coating.

Color Filter

Fixed wheel color filters: .044" thick, 2.039" diameter.

Gobo

Gobos are E size. ***Metal gobos are not acceptable.***



OPERATIONAL

Power Requirements

Standard AC power distribution from 200-240 VAC, 50/60 Hz. The unit requires up to 12 A depending on the AC supply voltage.

Operational Temperatures

-20° to 104°F (-29° to 40°C)

Cooling

Forced air cooled.

Control

Compatible with a wide variety of DMX512 consoles.

DMX Channels

36

Mounting Position:

The VL3015LT Spot luminaire can be mounted and operated in any orientation.

Weight

115 lbs. (52.3 kg)

Dimensions

Hangs on 31.0 inch (79 cm) centers. Luminaire can be mounted and operated in any orientation.

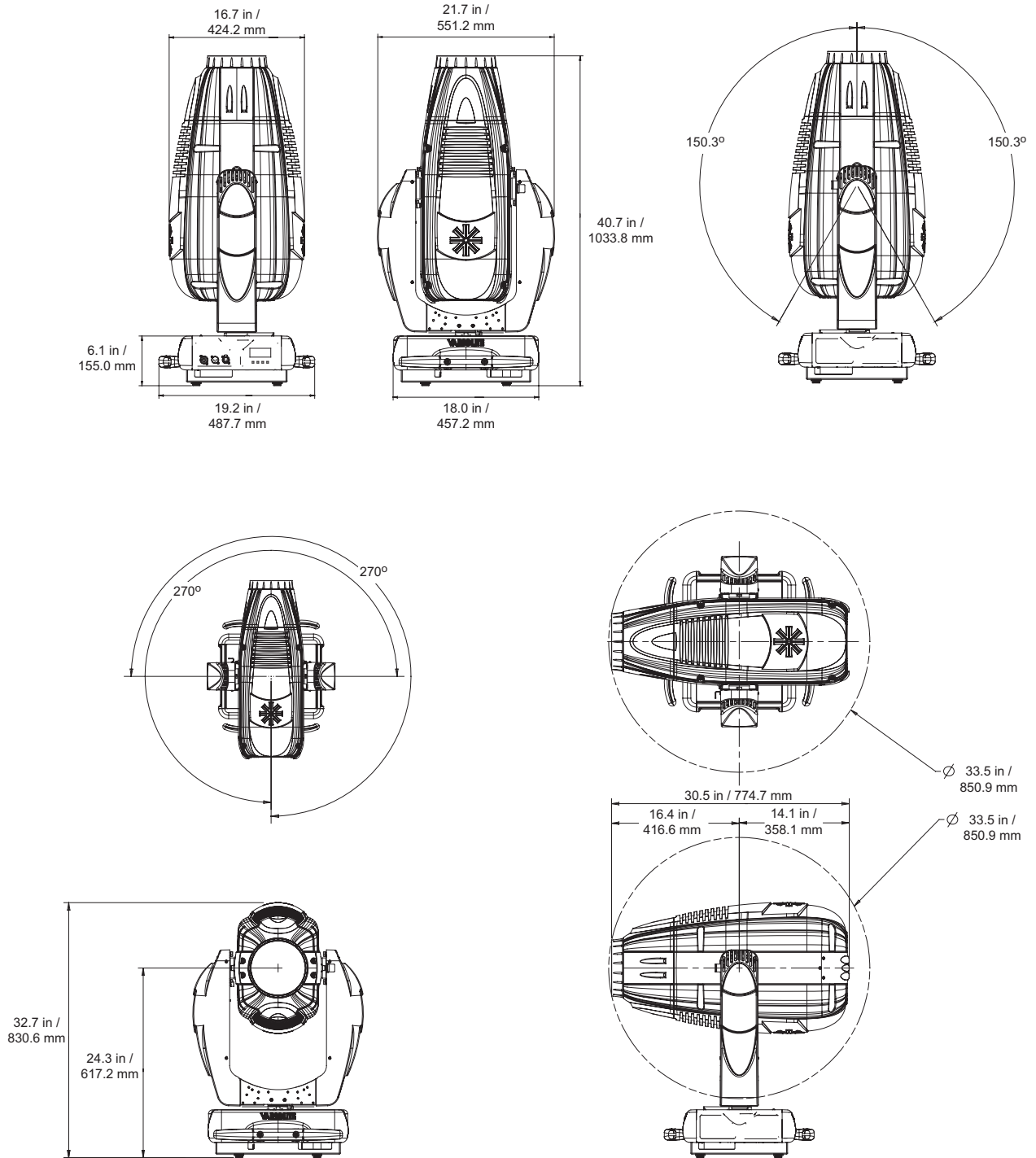



PHOTOMETRIC
1500W Short Arc Lamp

Zoom Lens Position	FIELD ANGLE (degrees)	TOTAL LUMENS	CCT
NFOV	5.6	19,854	6601
MFOV	32.0	41,487	
WFOV	52.1	34,226	

NOTES:

- A. All data taken with a seasoned light source at 20 hours of life.
- B. Fixture output = 41,487 lumens.

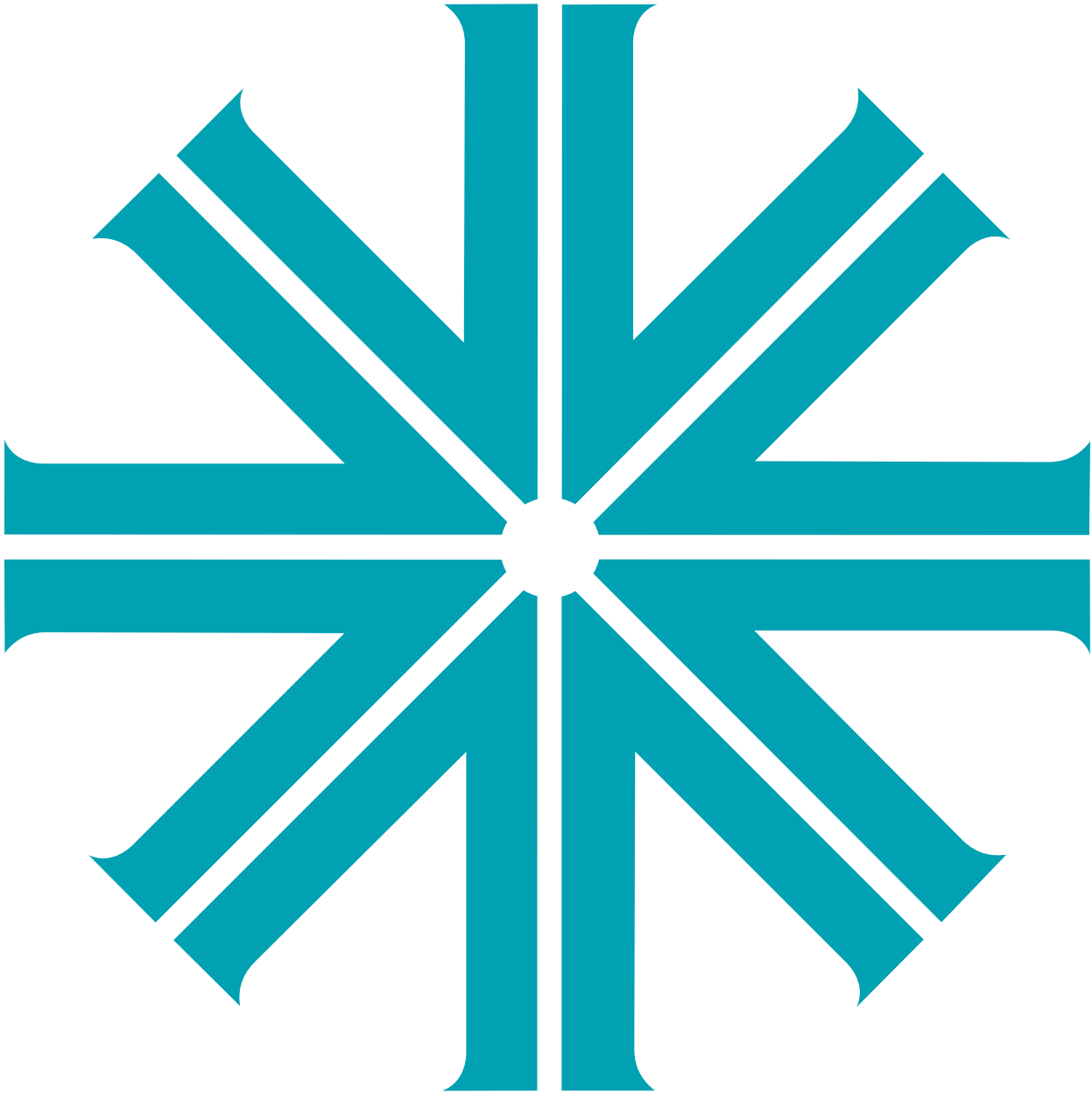

VARI*LITE

Express yourself.

Philips Vari-Lite
10911 Petal Street
Dallas, Texas 75238 USA
1-877-VARI-LITE . 1-214-647-7880
www.vari-lite.com

©2013 Philips Vari-Lite, a Philips group company. All Rights Reserved.