

Configuration palan à suspension industrielle (2 brins) Industrial suspension hoist configuration (2 fall)

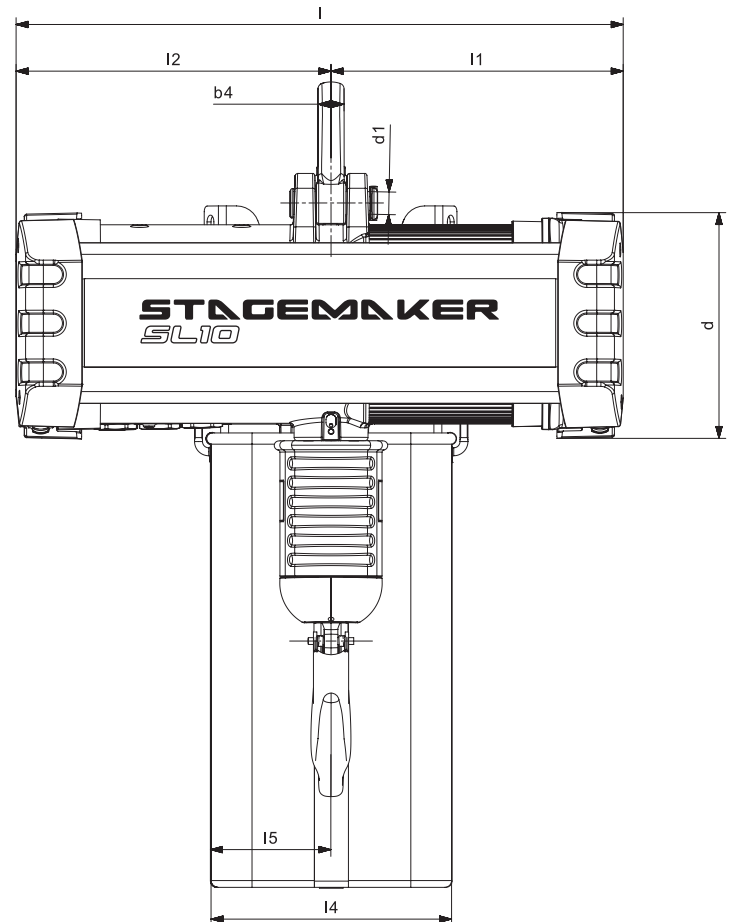
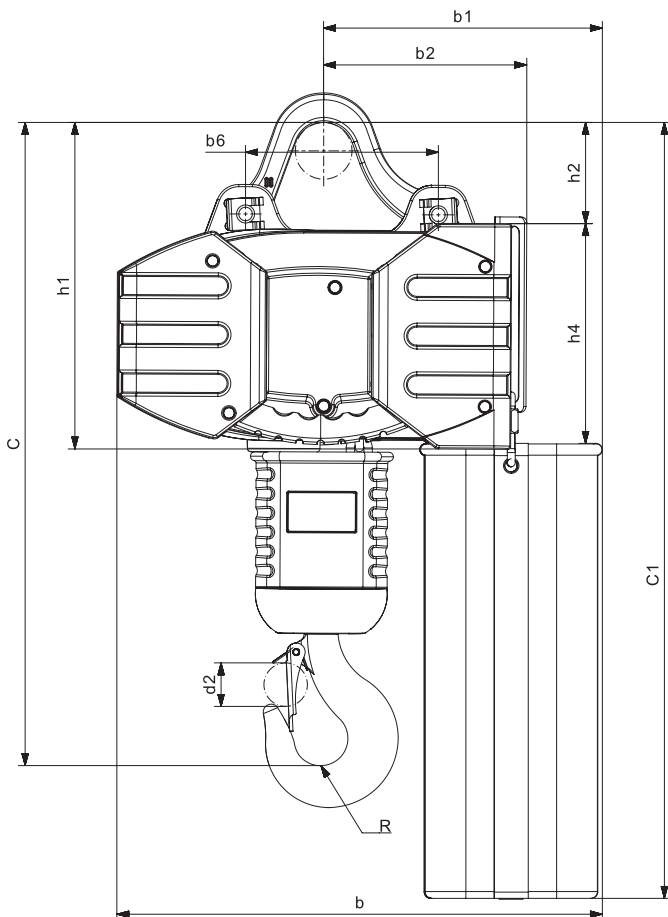

Corps de palan Chain hoist size	Moteur Motor	C	C1		b		b1		b2	b4	b6	d	d1	d2	R	h1	h2	h4
			Bac à chaîne Chain collector box size		Bac à chaîne Chain collector box size		Bac à chaîne Chain collector box size											
			H20	H40*	H20	H40*	H20	H40*										
SL10	MT10NB200	533	829	1029	430	448	235	232	179	29	170	199	20	27	21	404	196	232

Corps de palan Chain hoist size	Moteur Motor	I		I2	I1		Bac à chaîne Chain collector box size			
		Simple frein Single brake	Double frein + FdC à cames Double brake + GLS		Simple frein Single brake	Double frein + FdC à cames Double brake + GLS	Bac à chaîne Chain collector box size			
							H20	H40*	H20	H40*
SL10	MT10NB200	535	581	257	278	324	212	212	106	106

*H40 pour SL10

*H40 for SL10