

Showline

SL BEAM 300 FX LED Luminaire



Showline Offices

Showline - Dallas
10911 Petal Street
Dallas, TX 75238
Tel: 214-647-7880
Fax: 214-647-8030

Showline - Auckland
19-21 Kawana Street
Northcote, Auckland 0627
New Zealand
Tel: +64 9 481 0100
Fax: +64 9 481 0101

Showline - Europe
Marssteden 152
Enschede 7547 TD
The Netherlands
Tel: +31 53 4500424
Fax: +31 53 4500425

Showline - Asia
Unit C, 14/F, Roxy Industrial Centre
No. 41-49 Kwai Cheong Road
Kwai Chung, N.T., Hong Kong
Tel: +852 2796 9786
Fax: +852 2798 6545

Website:

www.philips.com/showline

The material in this manual is for information purposes only and is subject to change without notice. Showline assumes no responsibility for any errors or omissions which may appear in this manual. For comments and suggestions regarding corrections and/or updates to this manual, please visit the Showline website at www.philips.com/showline or contact your nearest Showline office.

El contenido de este manual es solamente para información y está sujeto a cambios sin previo aviso. Showline no asume responsabilidad por errores o omisiones que puedan aparecer. Cualquier comentario, sugerencia o corrección con respecto a este manual, favor de dirijirlo a la oficina de Showline más cercana.

Der Inhalt dieses Handbuchs ist nur für Informationszwecke gedacht, Änderungen sind vorbehalten. Showline uebernimmt keine Verantwortung für Fehler oder Irrtuemer, die in diesem Handbuch auftreten. Für Bemerkungen und Verbesserungsvorschlaege oder Vorschlaege in Bezug auf Korrekturen und/oder Aktualisierungen in diesem Handbuch, moechten wir Sie bitten, Kontakt mit der naechsten Showline-Niederlassung aufzunehmen.

Le matériel décrit dans ce manuel est pour information seulement et est sujet à changements sans préavis. La compagnie Showline n'assume aucune responsabilité sur toute erreur ou omission inscrite dans ce manuel. Pour tous commentaires ou suggestions concernant des corrections et/ou les mises à jour de ce manuel, veuillez s'il vous plait contacter le bureau de Showline le plus proche.

Note: Information contained in this document may not be duplicated in full or in part by any person without prior written approval of Showline. Its sole purpose is to provide the user with conceptual information on the equipment mentioned. The use of this document for all other purposes is specifically prohibited.

Document Number: **SL BEAM 300 FX User's Manual**

Version as of: 23rd Sep, 2015 Rev1.1

SL BEAM 300 FX LED Luminaire installation & User's Manual
© 2015 Philips Group. All rights reserved.

IMPORTANT INFORMATION

Warnings and Notices

When using electrical equipment, basic safety precautions should always be followed including the following:



- a. **READ AND FOLLOW ALL SAFETY INSTRUCTIONS.**
- b. Do not use outdoors.
- c. Do not mount near gas or electric heaters.
- d. Equipment should be mounted in locations and at heights where it will not readily be subject to tampering by unauthorized personnel.
- e. The use of accessory equipment not recommended by the manufacturer may cause an unsafe condition.
- f. Do not use this equipment for other than intended use.
- g. Refer service to qualified personnel.

SAVE THESE INSTRUCTIONS.



WARNING: You must have access to a mains circuit breaker or other power disconnect device before installing any wiring. BE sure that power is disconnected by removing fuses or turning the mains circuit breaker off before installation. Installing the device with power on may expose you to dangerous voltages and damage the device. A qualified electrician must perform this installation.

WARNING: Refer to National Electrical Code® and local codes for cable specifications. Failure to use proper cable can result in damage to equipment or danger to personnel.

WARNING: This equipment is intended for installation in accordance with the Nation Electric Code® and local regulations. It is also intended for installation in indoor applications only. Before any electrical work is performed, disconnect power at the circuit breaker or remove the fuse to avoid shock or damage to the control. It is recommended that a qualified electrician perform this installation.

Additional Resources for DMX512

For more information on installing DMX512 control systems, the following publication is available for purchase from the United States Institute for Theatre Technology (USITT), "Recommended Practice for DMX512: A Guide for Users and Installers, 2nd edition" (ISBN: 9780955703522). USITT Contact Information:

USITT
315 South Crouse Avenue, Suite 200
Syracuse, NY 13210-1844
Phone: 1.800.938.7488 or 1.315.463.6463
www.usitt.org

Showline Limited Two-Year Warranty

Showline offers a two-year limited warranty of its luminaires against defects in materials or workmanship from the date of delivery. A copy of Showline two-year limited warranty containing specific terms and conditions can be obtained by contacting your local Showline office.

TABLE OF CONTENTS

Showline Offices	Inside Front Cover
IMPORTANT INFORMATION	
Warnings and Notices	1
Additional Resources for DMX512	1
Showline Limited Two-Year Warranty	1
TABLE OF CONTENTS	
PREFACE	
About this Manual	4
Included Items	4
Accessories	4
SL BEAM 300 FX LED LUMINAIRE OVERVIEW	
SL BEAM 300 FX LED Luminaire Components	5
SL BEAM 300 FX LED Luminaire Menu System	6
INSTALLATION AND SET UP	
Connecting Power	7
Connecting SL BEAM 300 FX LED Luminaires to AC Power	8
Connecting to the DMX512 Network	9
Mounting Luminaire	10
OPERATION AND PROGRAMMING	
LCD Display and Menu System	11
LCD Display and Menu System Operation	11
SL BEAM 300 FX LED Luminaire Menu Options	12
Preset	12
Recalling or Editing presets	12
Color Filter	13
Effect	13
Edit user Chases	13
Edit Rainbow	14
Strobe/Timing	14
Settings/Security	15
Settings/General	16
Settings/Factory Default	16
Settings/DMX	16
Settings/Artnet Settings	17
Settings/Display	17
Lock Fixture	17
Password (PASSPIN)	18
Status	18
Quick Selection Button	18
DMX Address	18
Harmonize Color Calibration	19
Dimming Curve Selection	19
Master / Slave Operational Mode	20
DMX CONTROL	
SL BEAM 300 FX LED Luminaire DMX Mapping	21
Simple 8-Bit Mode	21
Simple 8-Bit Group Modes	22
RGBW 8-Bit Mode	23
RGBW 8-Bit Group Modes	27
RGBW 16-Bit Mode	28
RGBW 16-Bit Group Modes	32

HSIC Mode	33
HSIC Group Modes	34
Pattern Mode	35
Pattern Group Modes	38
DMX Timing Channel Detail	39
RDM PARAMETER IDS	
SL BEAM 300 FX LED Luminaire RDM Parameter IDs	45
CLEANING AND CARE	
Special Cleaning and Care Instructions	48
Front Lens Cleaning	48
Service and Maintenance	48
TECHNICAL SPECIFICATIONS	
Operational Specifications	49
Luminaire Dimensions	50

PREFACE

1. About this Manual

The document provides installation and operation instructions for the following products:

- SL BEAM 300 FX LED Luminaire

Please read all instructions before installing or using this product. *Retain this manual for future reference.* Additional product information and descriptions may be found on the product specification sheet.

Note: The SL BEAM 300 FX LED Luminaire is universal voltage 100 to 240 VAC (auto-ranging).

2. Included Items

Each SL BEAM 300 FX LED Luminaire includes the following items:

- SL BEAM 300 FX LED Luminaires
- PC1BE - AC Power Input Cable (39 inches / 1 meter), Powercon with Bare End* (**Note, user supplies and installs own AC input connector*)
- Quick Start Guide

SL BEAM 300 FX

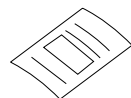
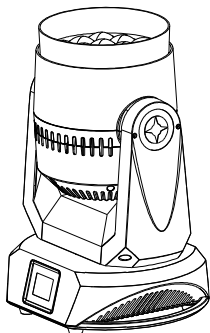

QuickStart Guide



Omega Mounts

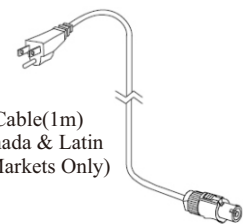

AC Input Cable(1m)
(USA, Canada & Latin
America Markets Only)

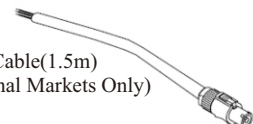

AC Input Cable(1.5m)
(International Markets Only)

Figure 1: Included Items

3. Accessories

SL BEAM 300 FX LED Luminaire Accessories

Part Number	Description
MC	Mega Claw, Black, Anodized
SC	Molded Yoke C-Clamp
HC	Light Weight Half Coupler
82003	Safety Cable

SL BEAM 300 FX LED LUMINAIRES OVERVIEW

1. SL BEAM 300 FX LED Luminaire Components

Major Luminaire Components

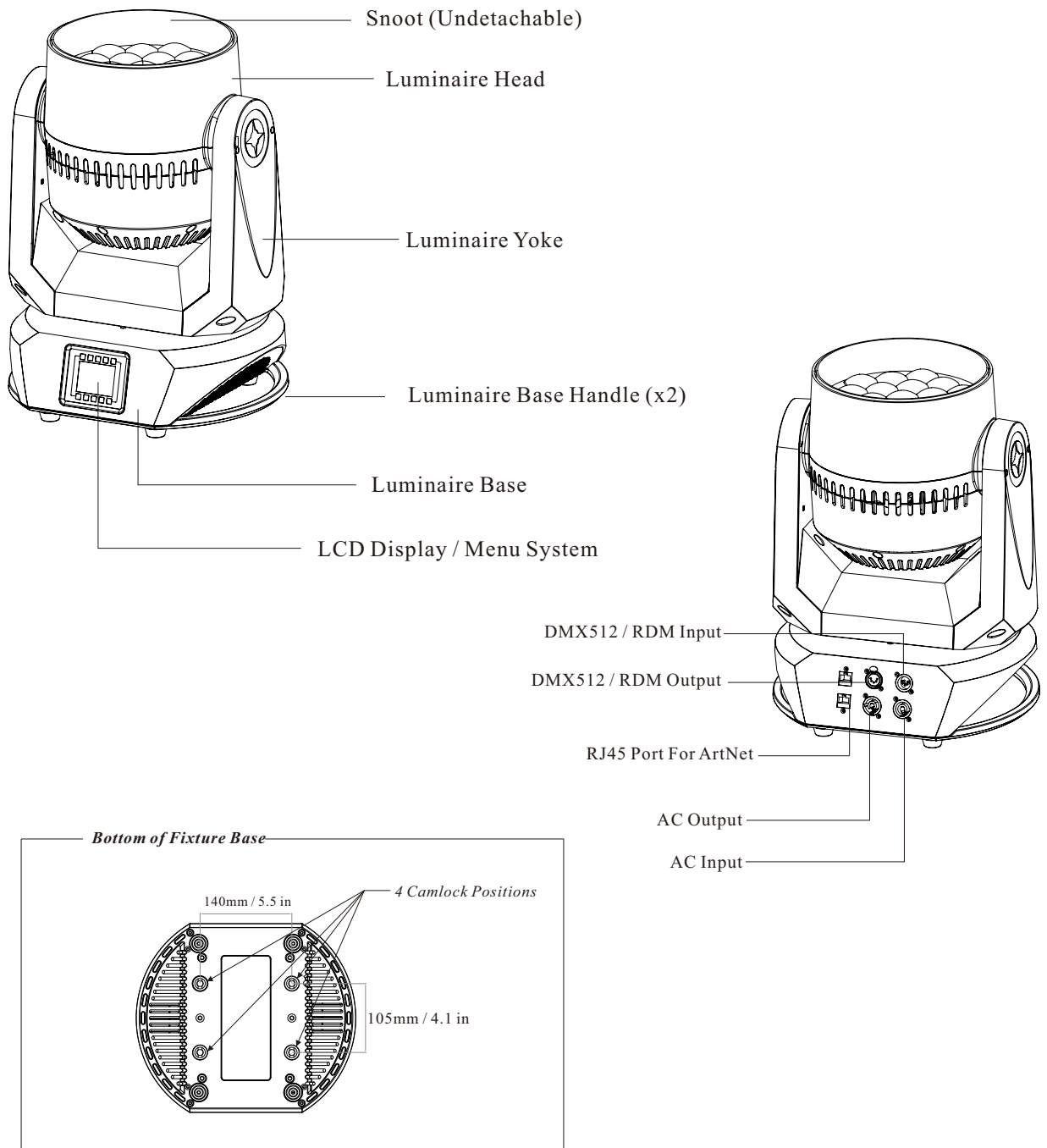

2. LCD Display / Menu System

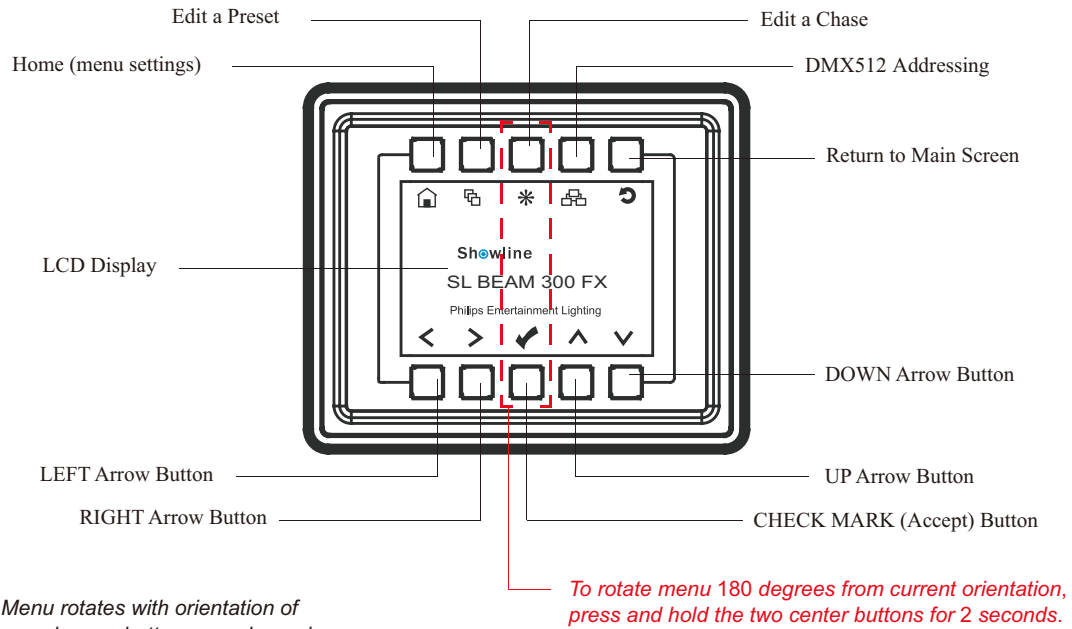

NOTE: Menu rotates with orientation of luminaire and menu buttons are always in the same position (with rotation of menu)

Figure 2: LCD Display & Menu System

Note: For Menu operation and programming details, refer to "LCD Display and Menu System" on page 9.

INSTALLATION AND SET UP

1. Power Requirements

The SL BEAM 300 FX LED Luminaires operate on AC input voltages from 100 to 240 VAC.



WARNING! SL BEAM 300 FX LED Luminaires do not contain an ON/OFF switch. Always disconnect power input cable to completely remove power from the luminaire when not in use.

AC Power Operation

When connected to an AC source, the luminaire operates on 100 to 240 volts AC (+/- 10%, auto-ranging). The luminaire contains an auto-ranging power supply. Each luminaire can draw up to 360 Watts.



WARNING! The maximum amount of fixtures that may be daisy-chained is (A) 4 units 100 ~ 120VAC or (B) 10 units 230 ~ 240VAC (15 Amps).

Note: For wiring of AC input connector, refer to "[Connecting SL BEAM 300 FX LED Luminaires to AC Power](#)" on page 7.

Table 1: SL BEAM 300 FX LED Luminaire Voltage (VAC) vs. Current*

Voltage (AC)	Total Current(A)	Maximum number of units that can be linked together*
100	3.60	4
110	3.27	4
120	3.00	5
130	2.77	5
140	2.57	5
150	2.40	6
160	2.25	6
170	2.12	7
180	2.00	7
190	1.89	7
200	1.80	8
210	1.71	8
220	1.63	9
230	1.56	9
240	1.50	10

WARNING! *These figures are based on the Maximum Allowable Input Current of 15 Amps (and the maximum power supply limit of 360 Watts for each connected unit). **Do not overload circuits!**



IMPORTANT AC POWER CONNECTION NOTE:

- When using the daisy-chain connection method, **ONLY** connect SL BEAM 300 FX LED Luminaires to AC Output Connection of SL BEAM 300 FX LED Luminaires. **DO NOT CONNECT OTHER TYPES OF LUMINAIRES OR DEVICES!**
- Use only use approved cable types.
- Do not overload circuits!
- Do not connect SL BEAM 300 FX LED Luminaires to dimmed circuits.
- The **MAXIMUM** allowable number of SL BEAM 300 FX LED Luminaires which can be "daisy-chained" on one power feed are listed in Table 1, above. **DO NOT EXCEED!**

2. Connecting Power

Luminaires can be powered in one of two ways:

- Direct connection to a AC power source using an AC input cable. For wiring of AC input connector, refer to "Connecting SL BEAM 300 FX LED Luminaires to AC Power" below.
- Connection from the AC output of another SL BEAM 300 FX LED Luminaire. When using this method, it is very important not to connect any other type of equipment device.



WARNING! Only connect other SL BEAM 300 FX LED Luminaires to the AC Output (Thru) connector of a SL BEAM 300 FX LED Luminaire.

Connecting SL BEAM 300 FX LED Luminaires to AC Power

If the luminaire is supplied with an AC input cable but you did not order an AC input connector, Table 2 describes how to connect power to your SL BEAM 300 FX LED Luminaire. Field wiring of the SL BEAM 300 FX LED Luminaire is straightforward. A total of 3 wires/conductors need to be brought to the luminaire. The following wiring scheme is required:

Table 2: SL BEAM 300 FX LED Luminaire (IP20 Rated Models) AC Input Connections

Wire Color	Purpose
Brown	Main/Line(100 to 240VAC)
Blue	Neutral
Green/Yellow	Ground (Earth)



CAUTION: In the event the AC input cable of this luminaire is damaged, it must be replaced, with an approved cable through an Authorized Showline Dealer or Service Center.

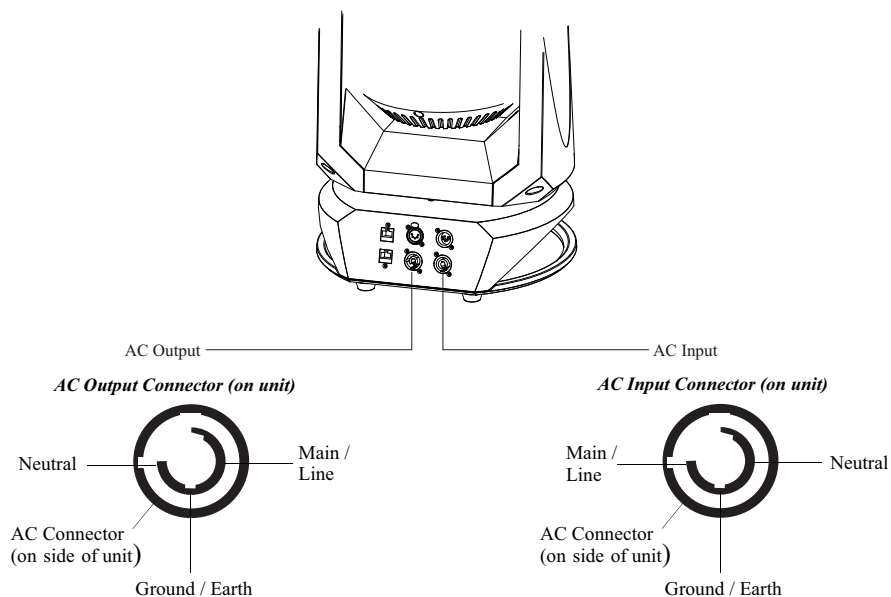

Figure 3: SL BEAM 300 FX LED Luminaire AC Input & Output Connections

3. Connecting to the DMX512 Network

Basic DMX512 installation consists of connecting multiple SL BEAM 300 FX LED Luminaires together (up to 32 luminaires) in "daisy-chain" fashion. A cable runs from the control console (or DMX512 control source) to the DMX connector on the first SL BEAM 300 FX LED Luminaire. Another cable runs from the other DMX connector on the first unit to a DMX connector on the next SL BEAM 300 FX LED Luminaire (or DMX512 device to be controlled).

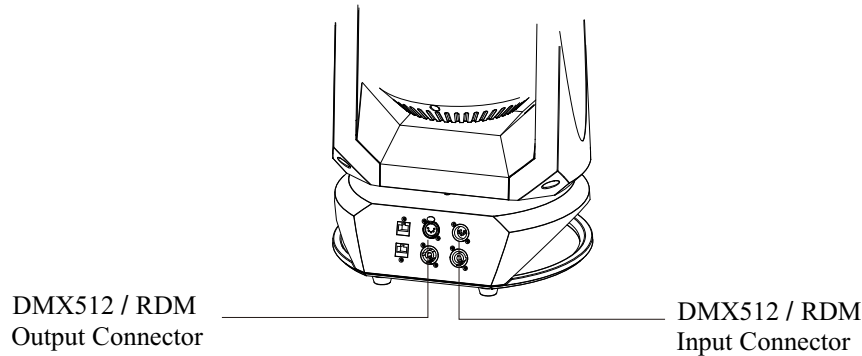
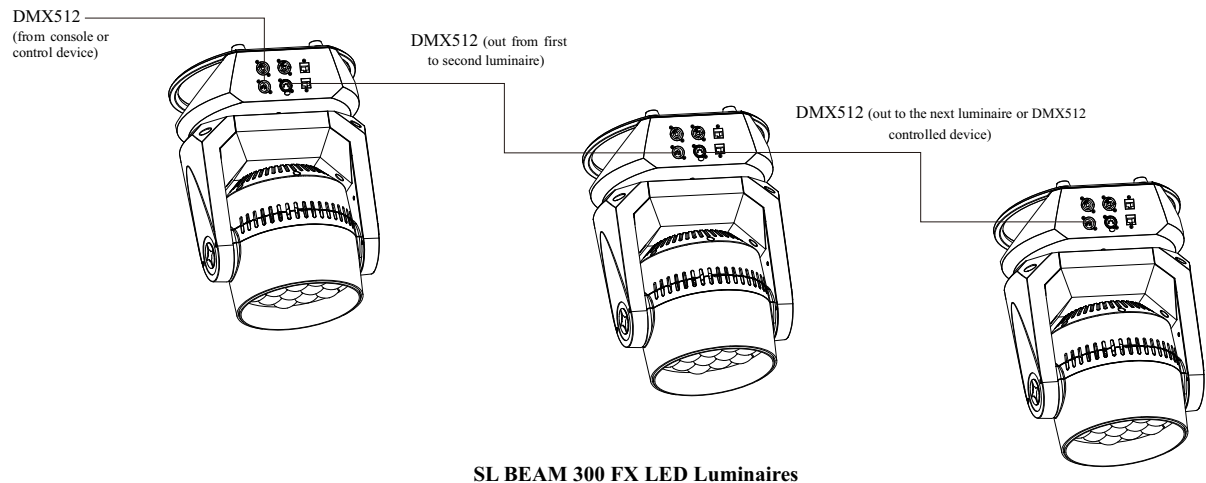

Figure 4: SL BEAM 300 FX LED Luminaire DMX512 Input / Output Connections

Note: For more information on DMX512 networking and systems, refer to ["Additional Resources for DMX512"](#) on [page 1](#). For SL BEAM 300 FX LED Luminaire DMX Mapping, refer to ["DMX CONTROL"](#) on [page 20](#).



SL BEAM 300 FX LED Luminaires

DMX512 Connections	
DMX512 Signal	XLR Pin
Common (Drain)	1
DMX512-	2
DMX512+	3

Note: Remaining pins on each connector are not used.

Figure 5: SL BEAM 300 FX LED Luminaire - DMX512 Connections

4. Mounting Luminaire

The SL BEAM 300 FX LED Luminaires are provided with the ability to hang via truss hooks, clamps, etc. (sold separately) or floor mounted (sitting on fixture base). Securely attach a hook, clamp, etc, to each Omega Mount (two supplied with luminaire). Attach the Omega Mounts to the luminaire base as illustrated in Figure 6 via the Camlocks.

It is recommended (and may be required by local and national safety codes) to use and install a safety cable (sold separately).

Whether hanging the fixture or free-standing on its base, be sure to leave enough space around the luminaire to allow proper, uninterrupted airflow for cooling and fixture head movement.

Note: Mounting hooks, clamps, safety cables, etc. are sold separately or by others. For mounting accessories available for this product, refer to "[Accessories](#)" on page 3.

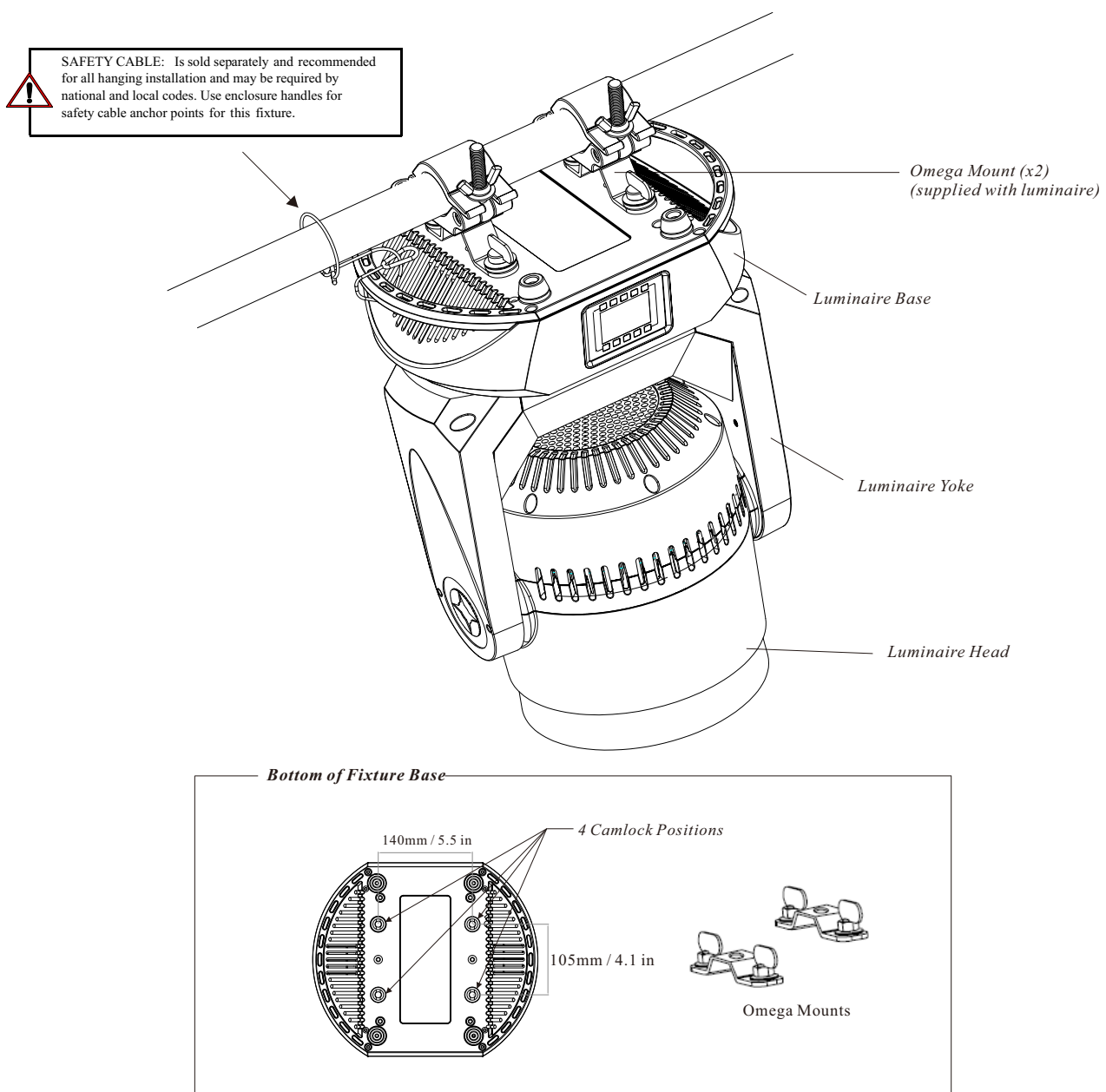

Figure 6: Mounting the Fixture - Hanging Applications

OPERATION AND PROGRAMMING

1. LCD Display and Menu System

SL BEAM 300 FX LED Luminaires

The SL BEAM 300 FX LED Luminaire's LCD Display and Menu System provides local control for accessing the following fixture's settings:

- Presets (Standard and User Defined)
- Color Filter
- Effects (Chases - preloaded and user defined)
- Strobe / Timing
- Settings
- Lock Fixture (to prevent changes)
- Password
- Status

Note: If there are multiple luminaires in a system, changes would need to be made at each LCD Menu as desired.

Upon power up, the LCD will display the main screen showing the product type/name. If DMX is enabled, the programmed address will appear after power up.

2. LCD Display and Menu System Operation

The LCD Display Menu system consists of several categories. Use the Menu Buttons to access and make changes to the menu items. When the desired menu item is reached, press the desired Menu Button to display the menu options and to navigate and configure the menu options as required.

To navigate and access menu settings/selections:

Step 1. Make sure unit is powered and turned on.

Step 2. Press the desired button (as shown in **Figure 7**) to access menu categories.

Step 3. Use UP | DOWN | LEFT | RIGHT arrow buttons to navigate through the various options and settings.

Step 4. Make changes as desired.

Press CHECK MARK (OK) button to accept changes.

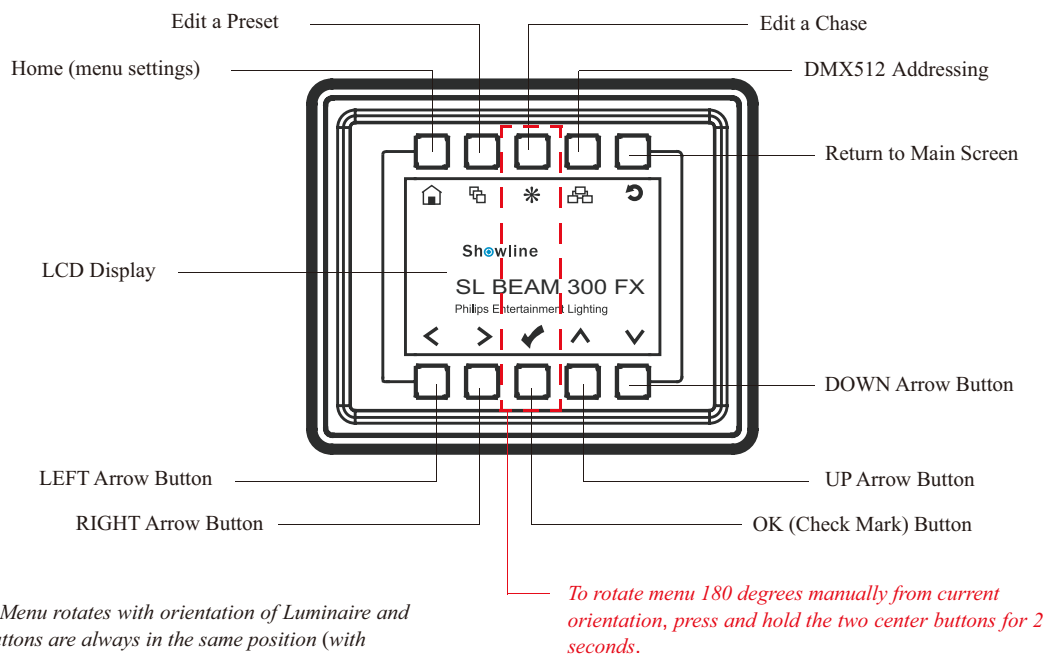

Figure 7: LCD Display and Menu System

3. SL BEAM 300 FX LED Luminaire Main Menu Options

Preset

Presets are stored values of the luminaire’s LED settings that can be recalled via the menu system or DMX. You can customize up to 31 presets via the menu system.

Recalling or Editing Presets

To recall or edit presets

- Step 1. Select Preset from the main menu or from the preset shortcut key.
- Step 2. The top left field indicates the current preset or Off, when this field is selected (highlighted in blue), use the left and right buttons to scroll through all presets.
- Step 3. If you wish to edit the preset, use the Up and Down keys to scroll through the parameters. Once a parameter is selected, use the left and right arrow buttons to make adjustments.

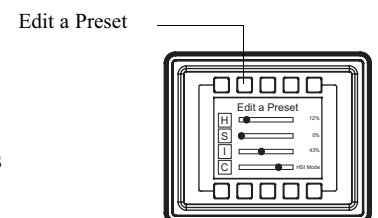

Notes:

- If security features are enabled, the Up and Down arrows will have no effect. See “Settings/Security” on page 15.
 - Depending on the DMX map set assigned the DMX menu, different either RGBW or HSIC parameters will be available.
- Step 4. Once all values are adjusted as desired, press the Check Mark button to save the preset.
 - Step 5. The Save Preset Menu option will appear. Use the left and right arrow buttons to select the preset number to save to.

Note: This function allows you to save your current edits to a different preset number than you began editing. This is helpful to create copies of existing presets.

Step 6. Press the Check Mark button to save the preset. You will be asked to confirm your saving operation.

Step 7. The preset is now saved and can be recalled via the menu or DMX.

Color Filter

Color filters are 43 factory made colors that utilize the Harmonize Color Calibration system (refer to “Harmonize Color Calibration” on page 19 for more information). They can be recalled via the menu system or DMX.

To recall a color filter from the menu:

Step 1. Select Color Filter from the main menu.

Step 2. The top indicates the current color filter or Off, when this field is selected (highlighted in blue), use the left and right buttons to scroll through all color filters.

Step 3. Use the Up and Down arrow keys to toggle to the Master Intensity field. use the Left and Right arrow keys to adjust the Master Intensity.

Step 4. The menu will display a graphical indication of the color along with the color name.

Note: The color filter will remain ON until you select a preset, chase, other color filter or send the unit DMX.

Effects

Effects are chases stored values of the luminaire's LED settings that can be recalled via the menu system or DMX. There are 10 factory defined chases and eight user adjustable chases. You can adjust the master intensity, speed, and fade values for any of the 18 chases.

Use the Up and Down buttons to select parameters and the Left and Right buttons to assign the different general fixture settings. When finished, press the Check button to exit the menu level. The adjustable parameters are described in Table 3.

Table 3: Effects parameters

Parameter	Description
User Chase / Built-in Chase	Select from the 18 different chases.
Master Intensity	Ajust the master intensity for ALL chases.
Total Steps	Displays the total steps used by the chase. This field is not editable.
Speed	The total time each step of the chase will be recalled.
Fade	The percentage of the time assigned by the speed that is crossfaded between steps.

Editing User Chases

Eight User chases can be further customized to create different effects on the fixture. To edit a User Chase, first use the up and down arrows to scroll to the Edit User Chase field and then press the Check Mark button. The Edit User Chase window will be displayed:

Use the Up and Down buttons to select parameters and the Left and Right buttons to assign the different general fixture settings. When finished, press the Check button to exit the menu level. The adjustable parameters are described in Table 4.

Edit a Chase

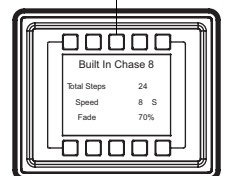

Table 4: User Chase parameters

Parameter	Description
User Chase	Select which chase you wish to edit.
Total Steps	Displays the total steps used by the chase. This field is not editable.
Edit Step	Select a step to edit with the left right arrow buttons. Press the Check Mark button to edit the step. (see To edit and save a Step)
New Step	Add a step to the end of the chase. Press the Check Mark button to edit the new step (see To edit and save a Step)
Delete Step	Delete the currently selected step in the Edit Step field. Press the Check mark button to delete the current step.
Rainbow	Press the Check mark button to display the Rainbow Chase editor.

To edit and save a Step:

- Step 1. Select Edit Step or New Step from the Edit User Chase menu.
- Step 2. The top left field indicates the preset or color filter to be used for the step. When set to OFF no preset or color filter is to be used. Use LEFT and RIGHT buttons to scroll through all presets and color filters.
- Step 3. Use the Up and Down keys to scroll through the output parameters. Once a parameter is selected, use the left and right arrow buttons to make adjustments.

Notes:

- If security features are enabled, the Up and Down arrows will have no effect. See “Settings/Security” on page 13.
- Fixtures with multiple pixel control include a parameter titled “Pixel” that allows you to independently adjust the output of each individual pixel or the entire fixture.
- Depending on the DMX map set assigned the DMX menu, different either RGBW or HSIC parameters will be available.

Step 4. Once all values are adjusted as desired, press the Check Mark button to return to the Edit User Chase screen.

Step 5. Continue editing steps as needed. When complete, press the Return to Main Menu button or up one level (as shown to the right). to exit the Edit User Chase window.



Step 6. The user chase is now saved and can be recalled via the menu or DMX.

Edit Rainbow:

An additional option in the Edit User Chase options is to have the fixture generate a multi-colored chase using different pixels from the fixture. When you select Rainbow from the Edit Step window the Edit Rainbow window will display the following options.

Table 5: Edit Rainbow parameters

Parameter	Description
Direction	Select either right or left to define the direction the rainbow effect runs.
Mode	Select from Mode 1 / Mode 2.
Number of Color	Select the number of colors used in the rainbow effect.
Current Color	Will display the values of the current color selected. Press the Check Mark button to edit the selected color.

Use the Up and Down buttons to select parameters and the Left and Right buttons to assign the settings. When finished, press the Check button to exit the menu level.

The bottom of the Edit Rainbow window displays a graphical representation of the current rainbow effect. When finished editing the Rainbow, press the Main Menu button (as shown to the right). You will be asked to confirm that you wish to save the rainbow. Select Yes to save and return to the Edit a Chase window.



Strobe/Timing

The Strobe/Timing menu allows you to assign strobe and timing values from the menu system. These settings are instantly applied to any active Preset, Color filter, or Chase.

Use the Up and Down buttons to select parameters and the Left and Right buttons to adjust the currently selected parameters. The adjustable parameters are described in Table 6 on page 13.

Table 6: Strobe/Timing Parameters

Parameter	Description
Master Intensity	Overall fixture output intensity level.
Strobe: X	Strobe mode and rate value settings following DMX map (see DMX CONTROL for details).
Duration	The time each strobe flash remains ON.
RotateMode	The way how the fixture will rotate.
Position	The exact position for the INDEX from Rotate Mode (0-255)

Settings/Security

All Showline fixtures have a multiple level locking feature. This allows you to configure the fixture and allow different menu access to multiple users. The menu system can be lock instantly or assigned to power on to a particular lock level. You can assign three different 4-digit PIN(personal identification number) codes to each unlock specific levels of functionality within the menu system.

Anytime the fixture is locked, each PIN code will unlock all functions except the pertaining features assigned via the security level.

Note: The Level 3 PIN will always unlock all functions.

Table 7: Security Lock Levels

Lock Level	Menu Functions Affected
Level 1	Edit Presets, Edit Chases, and Settings Menu
Level 2	Settings Menu
Level 3	All

Use the Up and Down buttons to select security PIN codes. Press the Check button and then use Left and Right and Up Down buttons to assign the pin code. Press the Check button to save the new PIN code.

The Power-Up Level parameters assigns a lock level to the fixture when power is applied. use the Up and Down buttons to select the Power-Up Level, and then use the Left and Right buttons to select the Power-up Level option.

Table 8: PIN Level Parameters

Parameter	Description
Enter Pass PIN	Enter a PIN code matching the level codes assigned in the Settings/Security menu to toggle the current security level.
Level 1 PIN	Edit the PIN code used to toggle the Level 1 security.
Level 2 PIN	Edit the PIN code used to toggle the Level 2 security.
Level 3 PIN	Edit the PIN code used to toggle the Level 3 security.
Power-up Level	Select the security level to default to when the fixture is powered ON. <ul style="list-style-type: none"> . Disable PIN will disable all security functions. . Lock will lock all functions.

Settings/General

Use the Up and Down buttons to select parameters and the Left and Right buttons to assign the different general fixture settings. When finished, press the Check button to exit the menu level. The adjustable parameters are described in Table 9.

Table 9: General Level Parameters

Parameter	Description
Power-Up	Select the action of the fixture when the unit is powered ON. You can select from Off, Last Set, Color filters, presets, and chases.
Mode	Select either Master/Slave (see Master / Slave Operational Mode for more information).
Dim Response	Select Normal or Incandescent dimming response. <ul style="list-style-type: none"> Normal: Fixture LEDs dim with a normal response. Incandescent: Fixture LED's dim with an incandescent emulation response. The response to dimming commands will be slightly delayed at lower intensities.
Dimming Curve	Select one of four dimming curve choices (see Dimming Curve Selection for more information).
Calibration	Toggle Harmonize Color Calibration on or off (see Harmonize Color Calibration for more information).
Fan Control	Select Auto or Off fan operation (see DMX CONTROL for more information).

Settings/Factory Default

Factory default menu settings can be recalled through this menu option. You can select if you wish to overwrite the user edited presets and chases.

Use the Up and Down buttons to select parameters and the Left and Right buttons to assign the different settings. When finished, press the Check button to exit the menu level. The adjustable parameters are described in Table 10.

Table 10: Factory Default Parameters

Parameter	Description
Protected	<ul style="list-style-type: none"> No - all menu items are able to be restored to factory defaults. Preset & Chase - user edited Presets and Chases are not able to be restored to factory defaults.
Load Factory	<ul style="list-style-type: none"> No - no action. Yes - restored to factory default menu settings.

Settings/DMX

DMX configuration options are available in the DMX menu.

Use the Up and Down buttons to select parameters and the Left and Right buttons to assign the fixture's DMX settings. When finished, press the Check button to exit the menu level. The adjustable parameters are described in Table 11.

Table 11: DMX Setting Parameters

Parameter	Description
DMX Enable	<ul style="list-style-type: none"> Enable - Fixture will respond to DMX commands/signals. disable - Fixture will ignore DMX commands/signals.
Address	Assigns the fixture's DMX start address.
Map	Select the DMX map for the fixture to use (see DMX CONTROL section for more information).
When no DMX	Selects the action of the fixture when the unit is powered ON and not receiving DMX <ul style="list-style-type: none"> Off - Turn off all LED output. Last Action - restore the last menu action. Power-up - follow the power-up value in the settings menu. Hold - continue with the last DMX values received.
LED Group	Select the number of LED groups to control via DMX (see DMX CONTROL section for more information).
Pan/Tilt Setting	Set the parameters for Pan/Tilt

Settings/ArtNet Settings

Use the Up and Down buttons to select parameters and the Left and Right buttons to assign the different general fixture settings. When finished, press the Check button to exit the menu level. The adjustable parameters are described in Table 12.

Table 12: ArtNET Parameters

Parameter	Description
IP Address	Set the IP address for the fixture.
Net	Select a Net number from 0-255
Sub-Net	Select a Sub-Net number from 0-15
Universe	Select a Universe number from 0-15.
Protocol Priority	<ul style="list-style-type: none"> • DMX > ArtNET - DMX will run first priority. • ArtNET > DMX - ArtNET will run first priority.

Settings / Display

Options of the fixture's LCD display can be adjusted in the Display menu.

Use the Up and Down buttons to select parameters and the Left and Right buttons to assign the fixture's DMX settings. When finished, press the Check button to exit the menu level. The adjustable parameters are described in Table 13.

Table 13: LCD Display Parameters

Parameter	Description
Flip Display	<ul style="list-style-type: none"> • Yes - The display will be inverted. • No - The display will not be inverted. • Auto - The display will automatically invert depending upon fixture orientation.
Off Time	Assign a time for the display to automatically turn off after the last button press. A value of ON will leave the display on indefinitely.
Language Selected	English is the only language supported.

Lock Fixture

You can lock all fixture functions, requiring a PIN code to access the menu functions. When you select this menu item, you are asked to confirm that you wish to lock the fixture. Once locked, all menu items can only be accessed by entering one of the three PIN codes assigned in the Settings/Security menu. (see "Settings/Security" on page 15 for more information). The PIN code used to unlock the fixture will only unlock the functionality assigned to that particular PIN code.

Note: When the fixture is powered off, the Lock fixture function will be disabled. To assign fixture power-up security refer to (see "Settings/Security" on page 13 for more information).

Password (PassPIN)

The Password menu item will display an Enter PassPIN dialog box. Use the Up Down Left Right buttons to enter a PIN code matching the codes assigned in the Settings/Security menu to toggle the current security level.

Status





The Status screen displays the current value of the master intensity and each LED of the luminaires. The number of pixels will vary depending upon fixture type. The Up Down Left Right arrows to scroll through the different LEDs and view their levels.

- The last Status item displayed shows the RDM UID and current Firmware Version
- Press the Check Mark button to exit the Status screen.

Quick Selection Buttons

The Showline menu system includes four quick selection buttons on the top of the menu. These keys provide direct access to common functions and act as shortcut to main menu items as described in Table 14

Table 14: General Level Parameters

Quick select Button	Description
	Main Menu Refer to Settings/General for more information.
	Edit a Preset Refer to Recalling or Editing Presets for more information.
	Effects / Edit a Chase Refer to Effects and Editing User Chases for more information.
	DMX Start Address Refer to DMX Address for more information.
	Return to Main Menu / Return Up a Menu Item

DMX Address

You can display and edit the current DMX start address for the fixture by pressing the Quick Select button on the top of the menu system (as shown right).

The current DMX start address will be display in large digits.

To edit the DMX start address:

Step 1. Press the Check Mark button to begin the DMX start address editing.

The last digit will change to a blue color.

Step 2. use the UP and Down arrows to change the value of the currently selected digit.

Step 3. Use the Left and Right arrows to select another digit to adjust.

Step 4. Press the Check Mark button to save the new DMX Start Address.

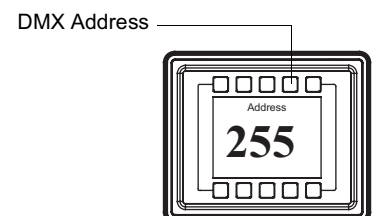

4. Harmonize Color Calibration

Harmonize is a proprietary, advanced LED color matching system, consisting of 3 correction modules: RGB, RGBW and Cool White/Warm White. Every Showline fixture undergoes rigorous testing to provide you with consistent control of color and intensity as well as output of the highest quality.

When enabled either via DMX or the fixture's menu, the Harmonize technology will ensure that colors match from fixture-to-fixture and pixel-to-pixel.

As the Harmonize system matches Showline products, they will all operate in the same color space. Use the Harmonize system when perfect color matching is an essential requirement.

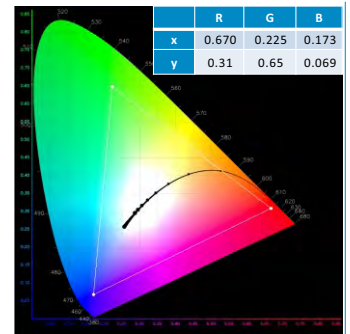

5. Dimming Curve Selection

Through the menu, you are able to select one of four dimming curves:

- Linear Curve
- PL_Curve
- S_Curve
- Square Curve

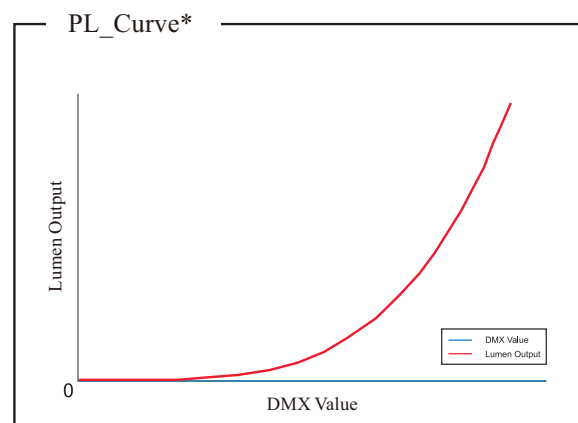
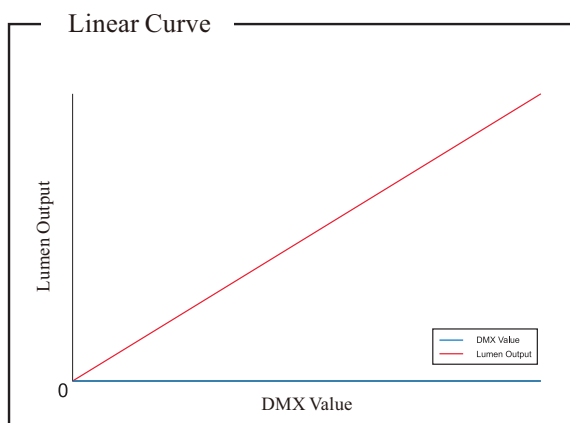

*PL Curve follows the dimming curve of Philips Selecon PL series LED luminaires.

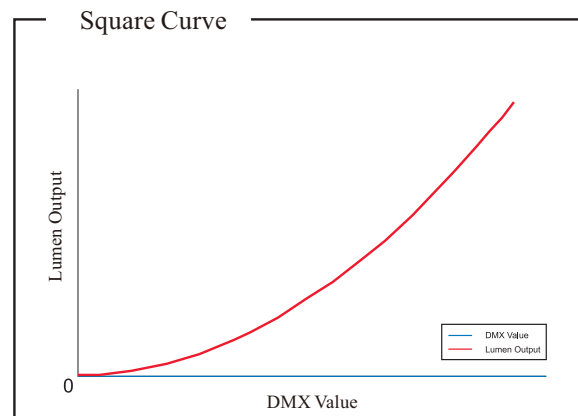
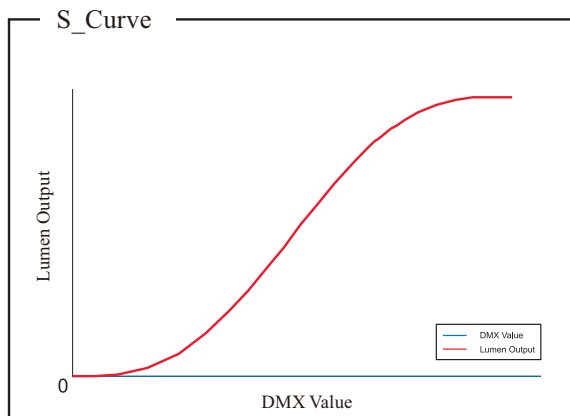

Figure 8: SL BEAM 300 FX LED Luminaire Dimmer Curves

6. Master / Slave Operational Mode

The Master / Slave Operational Mode allows one SL BEAM 300 FX LED Luminaire to act as the "Master" unit and all other connected units are controlled by this unit. When a unit is set to "Slave" mode, it will only listen to and follow any commands sent from a "Master" unit. Only one "Master" unit is allowed in this type of operation.

To setup a master / slave network:

- Step 1. Set the first device in the DMX512 chain to Master Mode through the unit's menu system.
- Step 2. Set all other connected units to Slave Mode.
- Step 3. The master unit can be controlled via DMX512, RDM or through standalone operation (self-contained network utilizing on-board effects). The slave units will mimic the master unit's operation in all cases.

Note: For more information on DMX512 networking and systems, refer to ["Additional Resources for DMX512"](#) on page 1. For SL BEAM 300 FX LED Luminaire DMX Mapping, refer to ["DMX CONTROL"](#) on page 19.

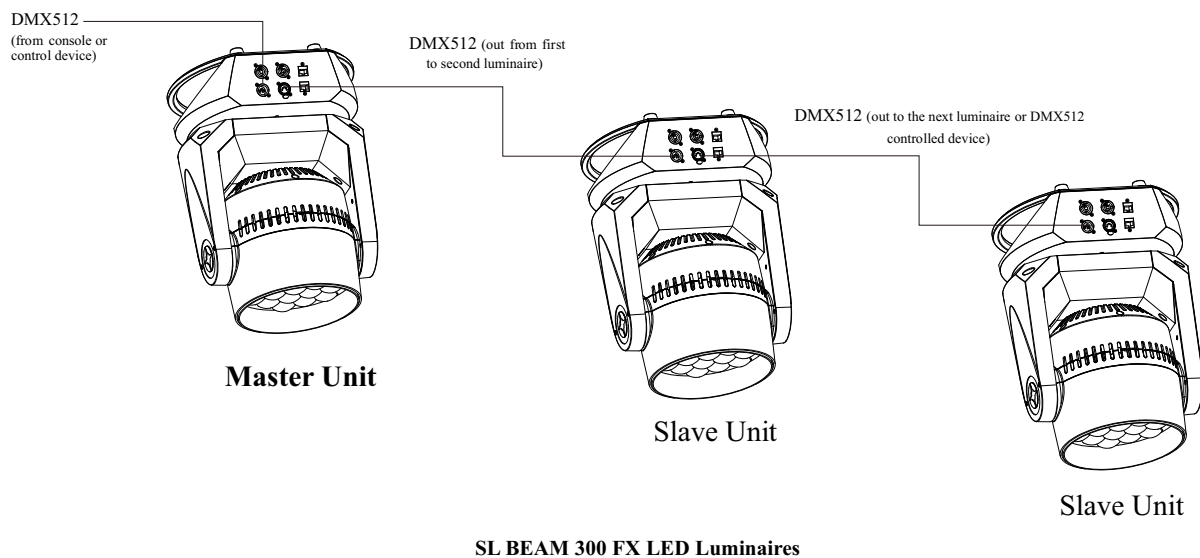

Figure 9: SL BEAM 300 FX LED Luminaire - Master / Slave Configuration

DMX CONTROL

This section contains information for operating the luminaire using DMX control in Simple 8-bit, RGBW 8-bit, RGBW 16-bit, HSIC (Hue, Saturation, Intensity and Color Correction) or Pattern modes. For Menu options and detailed information, see "LCD Display and Menu System" on page 6.

Note: These tables assume a DMX start address of 1. When a different starting address is used, this address becomes channel 1 function and other functions follow in sequence.

1. SL BEAM 300 FX LED Luminaire DMX Mapping

Simple 8-Bit Mode

Table 15 provides DMX channel mapping of all DMX512 control values when the SL BEAM 300 FX LED Luminaire is in simple 8-bit DMX512 mode (as set by the luminaire's menu system).

Table 15: SL BEAM 300 FX LED Luminaire DMX Channel Mapping (Simple 8 - Bit Mode)

DMX Channel	Parameter	Range DMX	Range%	Default	Description
1	Pan - High Byte	0-255	0-100%	128	8-bit control of Pan
2	Tilt - High Byte	0-255	0-100%	128	8-bit control of Tilt
3	Master Intensity	0-255	0-100%	0	8-bit control of Intensity of LED settings
4	Strobe	0-255	0-100%	0	Controls strobe operations as follows: Open DMX 0-2 Closed DMX 3-5 Slow Rand DMX 6-7 Med Rand DMX 8-10 Fast Rand DMX 11-12 Strobe Range DMX 13-127 (fastest) Pulse + Slow Rand DMX 128-129 Pulse + Med Rand DMX 130-131 Pulse + Fast Rand DMX 132-133 Pulse + Range DMX 134-191 Pulse - Slow Rand DMX 192-193 Pulse - Med Rand DMX 194-195 Pulse - Fast Rand DMX 197-197 Pulse - Range DMX 198-255
5	Zoom	0-255	0-100%	0	Variable control of zoom from 5° - 5°
6	Rotate Mode	0-255	0-100%	0	0-5% =DMX 0-14 OFF (Action same as Home) 6%-36% =DMX 15-93 Spin Mode 37%-67% =DMX 94-172 Index Mode 68%-100% =DMX 173-225 Reserved for future use
7	Position/Speed	0-255	0-100%	127	Spin Mode: 49%-51% Home 52% - 100%: Spin Speed Clockwise 48% - 0 : Spin Speed Counter Clockwise Index Mode: 49% - 51% Home 0 Degree 52%-100% Index Clockwise Home 0 degree to +180 degrees 48% - 0 Spin Index Counter Clockwise Home 0-180degrees
8	Control	0-255	0-100%	0	Set control channel value to desired action, hold value for at least 5 seconds, then turn to 0. Set control channel value to 0 without any scaling. Default Setting on Console =DMX 0-4 DIM Response_Normal =DMX 5-9 DIM Response_Incandescent =DMX 10-14 Dimming Curve_linear =DMX 30-34 Dimming Curve_Square =DMX 35-39 Dimming Curve_S-Curve =DMX 40-44 Diming Curve_PL-Curve =DMX 45-49 Calibration_OFF =DMX 70-74 Calibration_ON =DMX 75-79 Fan_Auto =DMX 80-84 Fan_Off =DMX 85-89 Reserved(Future Use) =DMX 90-250
9	Red 1-19	0-255	0-100%	0	8 bit control of Red LEDs from 0 to full.
10	Green 1-19	0-255	0-100%	0	8 bit control of Green LEDs from 0 to full.
11	Blue 1-19	0-255	0-100%	0	8 bit control of Blue LEDs from 0 to full.
12	White 1-19	0-255	0-100%	0	8 bit control of White LEDs from 0 to full.

Simple 8-Bit Group Modes

Table 16 provides DMX channel mapping of all DMX512 control values when the SL BEAM 300 FX LED Luminaire is operated in various Simple 8-bit DMX512 Group Control Modes.

Table 16: SL BEAM 300 FX LED Luminaire DMX Channel Mapping (Simple 8-Bit Group Modes)

Simple 8 bit mode		
DMX CHANNEL	19 Group Mode	1 Group Mode
1	Pan	Pan
2	Tilt	Tilt
3	Master Intensity	Master Intensity
4	Strobe	Strobe
5	Zoom	Zoom
6	Rotate Mode	Rotate Mode
7	Position/Speed	Position/Speed
8	Control	Control
9	Red_1	Red_1-19
10	Green_1	Green_19
11	Blue_1	Blue_19
12	White_1	White_19
13	Red_2	
14	Green_2	
15	Blue_2	
16	White_2	
17	Red_3	
18	Green_3	
19	Blue_3	
20	White_3	
21	Red_4	
22	Green_4	
23	Blue_4	
24	White_4	
25	Red_5	
26	Green_5	
27	Blue_5	
28	White_5	
29	Red_6	
30	Green_6	
31	Blue_6	
32	White_6	
33	Red_7	
34	Green_7	
35	Blue_7	
36	White_7	
37	Red_8	
38	Green_8	
39	Blue_8	
40	White_8	
41	Red_9	
42	Green_9	
43	Blue_9	
44	White_9	
45	Red_10	
46	Green_10	
47	Blue_10	
48	White_10	
49	Red_11	
50	Green_11	
51	Blue_11	
52	White_11	
53	Red_12	
54	Green_12	
55	Blue_12	
56	White_12	
57	Red_13	
58	Green_13	
59	Blue_13	
60	White_13	
61	Red_14	
62	Green_14	
63	Blue_14	
64	White_14	
65	Red_15	
66	Green_15	
67	Blue_15	
68	White_15	
69	Red_16	
70	Green_16	
71	Blue_16	
72	White_16	
73	Red_17	
74	Green_17	
75	Blue_17	
76	White_17	
77	Red_18	
78	Green_18	
79	Blue_18	
80	White_18	
81	Red_19	
82	Green_19	
83	Blue_19	
84	White_19	

RGBW 8 - Bit Mode

Table 17 provides DMX channel mapping of all DMX512 control values when the SL BEAM 300 FX LED Luminaire is in RGBW 8-Bit DMX512 mode (as set by the luminaire's menu system).

Table 17: SL BEAM 300 FX LED Luminaire DMX Channel Mapping (RGBW 8-Bit Mode)

DMX Channel	Parameter	Range DMX	Range%	Default	Description
1	Pan	0-255	0-100%	128	8-bit control of Pan
2	Tilt	0-255	0-100%	128	8-bit control of Tilt
3	Master Intensity	0-255	0-100%	0	8-bit control for Intensity of LED settings.
4	Color Presets	0-255	0-100%	0	Variable color Presets as follows . . . Channel OFF (disabled) DMX 0 - 4 Preset 0 (OFF) DMX 5 - 6 Preset 1 DMX 7 - 8 Preset 2 DMX 9 - 10 Preset 3 DMX 11 - 12 Preset 4 DMX 13 - 14 Preset 5 DMX 15 - 16 Preset 6 DMX 17 - 18 Preset 7 DMX 19 - 20 Preset 8 DMX 21 - 22 Preset 9 DMX 23 - 24 Preset 10 DMX 25 - 26 Preset 11 DMX 27 - 28 Preset 12 DMX 29 - 30 Preset 13 DMX 31 - 32 Preset 14 DMX 33 - 34 Preset 15 DMX 35 - 36 Preset 16 DMX 37 - 38 Preset 17 DMX 39 - 40 Preset 18 DMX 41 - 42 Preset 19 DMX 43 - 44 Preset 20 DMX 45 - 46 Preset 21 DMX 47 - 48 Preset 22 DMX 49 - 50 Preset 23 DMX 51 - 52 Preset 24 DMX 53 - 54 Preset 25 DMX 55 - 56 Preset 26 DMX 57 - 58 Preset 27 DMX 59 - 60 Preset 28 DMX 61 - 62 Preset 29 DMX 63 - 64 Preset 30 DMX 65 - 66 Preset 31 DMX 67 - 68 CF_0_Color OFF DMX 69 - 70 CF_1_White 1000K DMX 71 - 72 CF_2_White 8000K DMX 73 - 74 CF_3_White 6500K DMX 75 - 76 CF_4_White 5600K DMX 77 - 78 CF_5_White 5000K DMX 79 - 80 CF_6_White 4500K DMX 81 - 82 CF_7_White 4000K DMX 83 - 84 CF_8_White 3200K DMX 85 - 86 CF_9_White 3000K DMX 87 - 88 CF_10_White 2700K DMX 89 - 90

Table 17: SL BEAM 300 FX LED Luminaire DMX Channel Mapping (RGBW 8-Bit Mode)

DMX Channel	Parameter	Range DMX	Range%	Default	Description
4	Color Presets	0 - 255	0 - 100%	0	CF_11_Moroccan Pink DMX 91 - 92
					CF_12_Pink DMX 93 - 94
					CF_13_Flesh Pink DMX 95 - 96
					CF_14_Bright Rose DMX 97 - 98
					CF_15_Follies Pink DMX 99 - 100
					CF_16_Fuchsia Pink DMX 101 - 102
					CF_17_Surprise Pink DMX 103 - 104
					CF_18_Congo Blue DMX 105 - 106
					CF_19_Blue DMX 107 - 108
					CF_20_Virgin Blue DMX 109 - 110
					CF_21_Midnight Maya DMX 111 - 112
					CF_22_Double C.T Blue DMX 113-114
					CF_23_Slate Blue DMX 115 - 116
					CF_24_Regal Blue DMX 117 - 118
					CF_25_Full C.T Blue DMX 119-120
					CF_26_Steel Blue DMX 121 - 122
					CF_27_Lighter Blue DMX 123 - 124
					CF_28_Cyan DMX 125 - 126
					CF_29_Marine Blue DMX 127 - 128
					CF_30_Soft Green DMX 129 - 130
					CF_31_Moss Green DMX 131 - 132
					CF_32_Green DMX 133 - 134
					CF_33_Fem Green DMX 135 - 136
					CF_34_JAS Green DMX 137 - 138
					CF_35_Pale Green DMX 139 - 140
					CF_36_Spring Yellow DMX 141 - 142
					CF_37_Yellow DMX 143 - 144
					CF_38_Deep Amber DMX 145 - 146
					CF_39_Chrome Orange DMX 147 - 148
					CF_40_Orange DMX 149 - 150
					CF_41_Magenta DMX 151 - 152
					CF_42_Flame Red DMX 153 - 154
					CF_43_Purple DMX 155 - 156
					Rotate CW Fast → Slow DMX 157 - 171
					Rotate ACW Slow → Fast DMX 172 - 186
					Random Color Fast → Slow DMX 187 - 201

Table 17: SL BEAM 300 FX LED Luminaire DMX Channel Mapping (RGBW 8-Bit Mode)

DMX Channel	Parameter	Range DMX	Range%	Default	Description
4	Color Presets	0 - 255	0 - 100%	0	<p>Chase1 DMX 202 - 204</p> <p>Chase2 DMX 205 - 207</p> <p>Chase3 DMX 208 - 210</p> <p>Chase4 DMX 211 - 213</p> <p>Chase5 DMX 214 - 216</p> <p>Chase6 DMX 217 - 219</p> <p>Chase7 DMX 220 - 222</p> <p>Chase8 DMX 223 - 225</p> <p>Chase9 DMX 226 - 228</p> <p>Chase10 DMX 229 - 231</p> <p>User Chase1 DMX 232 - 234</p> <p>User Chase2 DMX 235 - 237</p> <p>User Chase3 DMX 238 - 240</p> <p>User Chase4 DMX 241 - 243</p> <p>User Chase5 DMX 244 - 246</p> <p>User Chase6 DMX 247 - 249</p> <p>User Chase7 DMX 250 - 252</p> <p>User Chase8 DMX 253 - 255</p>
5	Strobe	0 - 255	0 - 100%	DMX0	<p>Controls strobe operations as follows . . .</p> <p>Open = DMX 0 - 2</p> <p>Closed = DMX 3 - 5</p> <p>Slow Rand = DMX 6 - 7</p> <p>Med Rand = DMX 8 - 10</p> <p>Fast Rand = DMX 11 - 12</p> <p>Strobe Range = DMX 13 - 127 (fastest)</p> <p>Pulse + Slow Rand = DMX 128 - 129</p> <p>Pulse + Med Rand = DMX 130 - 131</p> <p>Pulse + Fast Rand = DMX 132 - 133</p> <p>Pulse + Range = DMX 134 - 191</p> <p>Pulse - Slow Rand = DMX 192 - 193</p> <p>Pulse - Med Rand = DMX 194 - 195</p> <p>Pulse - Fast Rand = DMX 196 - 197</p> <p>Pulse - Range = DMX 198 - 255</p>
6	Duration	0 - 255	0 - 100%	0	<p>Strobe's duration, Range is 0-85</p> <p>0 = DMX 0</p> <p>1 = DMX 1 - 3</p> <p>x = (DMX Value-1)/3+1</p> <p>85 = DMX 253-255</p>

Table 17: SL BEAM 300 FX LED Luminaire DMX Channel Mapping (RGBW 8-Bit Mode)

DMX Channel	Parameter	Range DMX	Range%	Default	Description
7	Zoom	0-255	0-100%	0	Variable control of zoom from 55°-5°
8	Rotate Mode	0-255	0-100%	0	0-5% =DMX 0-14 OFF (Action same as Home) 6%-36% =DMX 15-93 Spin Mode 37%-67% =DMX 94-172 Index Mode 68%-100% =DMX 173-225 Reserved for future use
9	Position/Speed	0-255	0-100%	0	Spin Mode: 49%-51% Home 52% - 100%: Spin Speed Clockwise 48% - 0 : Spin Speed Counter Clockwise Index Mode: 49% - 51% Home 0 Degree 52%-100% Index Clockwise Home 0 degree to +180 degrees 48% - 0 Spin Index Counter Clockwise Home 0-180degrees
10	Focus Timing	0-255	0-100%	255	Timing control of Pan/Tilt
11	Timing	0-255	0-100%	255	Allows for timing control of intensity, color, and zoom parameters. Channel should default to 255 for smoothest actions using console and/or manual fades. - See Timing Chart for more details.
12	Control	0-255	0-100%	0	Set control channel value to desired action, hold value for at least 5 seconds, then turn to 0. Set control channel value to 0 without any scaling. Default Setting on Console =DMX 0-4 DIM Response_Normal =DMX 5-9 DIM Response_Incandescent =DMX 10-14 Dimming Curve_linear =DMX 30-34 Dimming Curve_Square =DMX 35-39 Dimming Curve_S-Curve =DMX 40-44 Diming Curve_PL-Curve =DMX 45-49 Calibration_OFF =DMX 70-74 Calibration_ON =DMX 75-79 Fan_Auto =DMX 80-84 Fan_Off =DMX 85-89 Reserved(Future Use) =DMX 90-250
13	Red1-19	0-255	0-100%	0	8 bit control of Red LEDs from 0 to full
14	Green1-19	0-255	0-100%	0	8 bit control of Green LEDs from 0 to full
15	Blue1-19	0-255	0-100%	0	8 bit control of Blue LEDs from 0 to full
16	White1-19	0-255	0-100%	0	8 bit control of White LEDs from 0 to full

RGBW 8-Bit Group Modes

Table 18 provides DMX channel mapping of all DMX512 control values when the SL BEAM 300 FX LED Luminaire is operated in various RGBW 8-bit DMX512 Group Control Modes.

Table 18: SL BEAM 300 FX LED Luminaire DMX Channel Mapping (RGBW 8-Bit Group Modes)

RGBW 8 bit mode		
DMX CHANNEL	19 Group Mode	1 Group Mode
1	Pan	Pan
2	Tilt	Tilt
3	Master Intensity	Master Intensity
4	Color Presets	Color Presets
5	Strobe	Strobe
6	Duration	Duration
7	Zoom	Zoom
8	Rotate Mode	Rotate Mode
9	Position/Speed	Position/Speed
10	Focus Timing	Focus Timing
11	Timing	Timing
12	Control	Control
13	Red_1	Red_1-19
14	Green_1	Green_19
15	Blue_1	Blue_19
16	White_1	White_19
17	Red_2	
18	Green_2	
19	Blue_2	
20	White_2	
21	Red_3	
22	Green_3	
23	Blue_3	
24	White_3	
25	Red_4	
26	Green_4	
27	Blue_4	
28	White_4	
29	Red_5	
30	Green_5	
31	Blue_5	
32	White_5	
33	Red_6	
34	Green_6	
35	Blue_6	
36	White_6	
37	Red_7	
38	Green_7	
39	Blue_7	
40	White_7	
41	Red_8	
42	Green_8	
43	Blue_8	
44	White_8	
45	Red_9	
46	Green_9	
47	Blue_9	
48	White_9	
49	Red_10	
50	Green_10	
51	Blue_10	
52	White_10	
53	Red_11	
54	Green_11	
55	Blue_11	
56	White_11	
57	Red_12	
58	Green_12	
59	Blue_12	
60	White_12	
61	Red_13	
62	Green_13	
63	Blue_13	
64	White_13	
65	Red_14	
66	Green_14	
67	Blue_14	
68	White_14	
69	Red_15	
70	Green_15	
71	Blue_15	
72	White_15	
73	Red_16	
74	Green_16	
75	Blue_16	
76	White_16	
77	Red_17	
78	Green_17	
79	Blue_17	
80	White_17	
81	Red_18	
82	Green_18	
83	Blue_18	
84	White_18	
85	Red_19	
86	Green_19	
87	Blue_19	
88	White_19	

RGBW 16 - Bit Mode

Table 19 provides DMX channel mapping of all DMX512 control values when the SL BEAM 300 FX LED Luminaire is in RGBW 16-bit DMX512 mode (as set by the luminaire's menu system).

Table 19: SL BEAM 300 FX LED Luminaire DMX Channel Mapping (RGBW 16-Bit Mode)

DMX Channel	Parameter	Range DMX	Range%	Default	Description
1 2	Pan - High Byte Pan _ Low Byte	0 - 65535	0 - 100%	32768	16 bit control of Pan
3 4	Tilt - High Byte Tilt _ Low Byte	0 - 65535	0 - 100%	32768	16 bit control of Tilt
5 6	Master Intensity High Master Intensity Low	0 - 65535	0 - 100%	0	16 bit control for Intensity of LED settings
7	Color Presets	0 - 255	0 - 100%	0	Variable color Presets as follows . . . Channel OFF (disabled) DMX 0 - 4 Preset 0 (OFF) DMX 5 - 6 Preset 1 DMX 7 - 8 Preset 2 DMX 9 - 10 Preset 3 DMX 11 - 12 Preset 4 DMX 13 - 14 Preset 5 DMX 15 - 16 Preset 6 DMX 17 - 18 Preset 7 DMX 19 - 20 Preset 8 DMX 21 - 22 Preset 9 DMX 23 - 24 Preset 10 DMX 25 - 26 Preset 11 DMX 27 - 28 Preset 12 DMX 29 - 30 Preset 13 DMX 31 - 32 Preset 14 DMX 33 - 34 Preset 15 DMX 35 - 36 Preset 16 DMX 37 - 38 Preset 17 DMX 39 - 40 Preset 18 DMX 41 - 42 Preset 19 DMX 43 - 44 Preset 20 DMX 45 - 46 Preset 21 DMX 47 - 48 Preset 22 DMX 49 - 50 Preset 23 DMX 51 - 52 Preset 24 DMX 53 - 54 Preset 25 DMX 55 - 56 Preset 26 DMX 57 - 58 Preset 27 DMX 59 - 60 Preset 28 DMX 61 - 62 Preset 29 DMX 63 - 64 Preset 30 DMX 65 - 66 Preset 31 DMX 67 - 68

Table 19: SL BEAM 300 FX LED Luminaire DMX Channel Mapping (RGBW 16-Bit Mode)

DMX Channel	Parameter	Range DMX	Range%	Default	Description
7	Color Presets	0 - 255	0 - 100%	0	CF_0_Color OFF DMX 69 - 70 CF_1_White 10000K DMX 71 - 72 CF_2_White 8000K DMX 73 - 74 CF_3_White 6500K DMX 75 - 76 CF_4_White 5600K DMX 77 - 78 CF_5_White 5000K DMX 79 - 80 CF_6_White 4500K DMX 81 - 82 CF_7_White 4000K DMX 83 - 84 CF_8_White 3200K DMX 85 - 86 CF_9_White 3000K DMX 87 - 88 CF_10_White 2700K DMX 89 - 90 CF_11_Moroccan Pink DMX 91 - 92 CF_12_Pink DMX 93 - 94 CF_13_Flesh Pink DMX 95 - 96 CF_14_Bright Rose DMX 97 - 98 CF_15_Follies Pink DMX 99 - 100 CF_16_Fuchsia Pink DMX 101 - 102 CF_17_Surprise Pink DMX 103 - 104 CF_18_Congo Blue DMX 105 - 106 CF_19_Blue DMX 107 - 108 CF_20_Virgin Blue DMX 109 - 110 CF_21_Midnight Maya DMX 111 - 112 CF_22_Double C.T Blue DMX 113-114 CF_23_Slate Blue DMX 115 - 116 CF_24_Regal Blue DMX 117 - 118 CF_25_Full C.T Blue DMX 119-120 CF_26_Steel Blue DMX 121 - 122 CF_27_Lighter Blue DMX 123 - 124 CF_28_Cyan DMX 125 - 126 CF_29_Marine Blue DMX 127 - 128 CF_30_Soft Green DMX 129 - 130 CF_31_Moss Green DMX 131 - 132 CF_32_Green DMX 133 - 134 CF_33_Fem Green DMX 135 - 136 CF_34_JAS Green DMX 137 - 138 CF_35_Pale Green DMX 139 - 140 CF_36_Spring Yellow DMX 141 - 142 CF_37_Yellow DMX 143 - 144 CF_38_Deep Amber DMX 145 - 146 CF_39_Chrome Orange DMX 147 - 148 CF_40_Orange DMX 149 - 150 CF_41_Magenta DMX 151 - 152 CF_42_Flame Red DMX 153 - 154 CF_43_Purple DMX 155 - 156 Rotate CW Fast → Slow DMX 157 - 171 Rotate ACW Slow → Fast DMX 172 - 186 Random Color Fast → Slow DMX 187 - 201

Table 19: SL BEAM 300 FX LED Luminaire DMX Channel Mapping (RGBW 16-Bit Mode)

DMX Channel	Parameter	Range DMX	Range%	Default	Description
7	Color Presets	0 - 255	0 - 100%	0	<p>Chase1 DMX 202 - 204</p> <p>Chase2 DMX 205 - 207</p> <p>Chase3 DMX 208 - 210</p> <p>Chase4 DMX 211 - 213</p> <p>Chase5 DMX 214 - 216</p> <p>Chase6 DMX 217 - 219</p> <p>Chase7 DMX 220 - 222</p> <p>Chase8 DMX 223 - 225</p> <p>Chase9 DMX 226 - 228</p> <p>Chase10 DMX 229 - 231</p> <p>User Chase1 DMX 232 - 234</p> <p>User Chase2 DMX 235 - 237</p> <p>User Chase3 DMX 238 - 240</p> <p>User Chase4 DMX 241 - 243</p> <p>User Chase5 DMX 244 - 246</p> <p>User Chase6 DMX 247 - 249</p> <p>User Chase7 DMX 250 - 252</p> <p>User Chase8 DMX 253 - 255</p>
8	Strobe	0 - 255	0 - 100%	DMX0	<p>Controls strobe operations as follows . . .</p> <p>Open = DMX 0 - 2</p> <p>Closed = DMX 3 - 5</p> <p>Slow Rand = DMX 6 - 7</p> <p>Med Rand = DMX 8 - 10</p> <p>Fast Rand = DMX 11 - 12</p> <p>Strobe Range = DMX 13 - 127 (fastest)</p> <p>Pulse + Slow Rand = DMX 128 - 129</p> <p>Pulse + Med Rand = DMX 130 - 131</p> <p>Pulse + Fast Rand = DMX 132 - 133</p> <p>Pulse + Range = DMX 134 - 191</p> <p>Pulse - Slow Rand = DMX 192 - 193</p> <p>Pulse - Med Rand = DMX 194 - 195</p> <p>Pulse - Fast Rand = DMX 196 - 197</p> <p>Pulse - Range = DMX 198 - 255</p>
9	Duration	0 - 255	0 - 100%	0	<p>Strobe's duration, Range is 0-85</p> <p>0 = DMX 0</p> <p>1 = DMX 1 - 3</p> <p>x = (DMX Value-1)/3+1</p> <p>85 = DMX 253-255</p>

Table 19: SL BEAM 300 FX LED Luminaire DMX Channel Mapping (RGBW 16-Bit Mode)

DMX Channel	Parameter	Range DMX	Range%	Default	Description
10	Zoom	0 - 255	0 - 100%	0	Variable control of zoom from 55°-5°
11	Rotate Mode	0 - 255	0 - 100%	0	0-5% =DMX 0-14 OFF(Action same as Home) 6%-36% =DMX 15-93 Spin Mode 37%-67% =DMX 94-172 Index Mode 68%-100% =DMX 173-225 Reserved for future use
12	Position/Speed	0 - 255	0 - 100%	127	Spin Mode: 49%-51% Home 52% - 100%: Spin Speed Clockwise 48% - 0 : Spin Speed Counter Clockwise Index Mode: 49% - 51% Home 0 Degree 52%-100% Index Clockwise Home 0 degree to +180 degrees 48% - 0 Spin Index Counter Clockwise Home 0-180degrees
13	Focus Timing	0 - 255	0 - 100%	255	Timing control of Pan/Tilt
14	Intensity Timing	0 - 255	0 - 100%	255	Allows for timing control of intensity. Channel should default to 255 for smoothest actions using console and/or manual fades. - See Timing chart for more details.
15	Color Timing	0 - 255	0 - 100%	255	Allows for timing control of color. Channel should default to 255 for smoothest actions using console and/or manual fades. - See Timing chart for more details.
16	Zoom Timing	0 - 255	0 - 100%	255	Allows for timing control of zoom
17	Control	0 - 255	0 - 100%	0	Set control channel value to desired action, hold value for at least 5 seconds, then turn to 0. Set control channel value to 0 without any scaling. Default Setting on Console =DMX 0-4 DIM Response_Normal =DMX 5-9 DIM Response_Incandescent =DMX 10-14 Dimming Curve_linear =DMX 30-34 Dimming Curve_Square =DMX 35-39 Dimming Curve_S-Curve =DMX 40-44 Diming Curve_PL-Curve =DMX 45-49 Calibration_OFF =DMX 70-74 Calibration_ON =DMX 75-79 Fan_Auto =DMX 80-84 Fan_Off =DMX 85-89 Reserved(Future Use) =DMX 90-250
18 19	Red 1-19 - High Byte Red 1-19 - Low Byte	0 - 65535	0 - 100%	0	16 bit control of Red LEDs from 0 to full
20 21	Green 1-19 - High Byte Green 1-19 - Low Byte	0 - 65535	0 - 100%	0	16 bit control of Green LEDs from 0 to full
22 23	Blue 1-19 - High Byte Blue 1-19 - Low Byte	0 - 65535	0 - 100%	0	16 bit control of Blue LEDs from 0 to full
24 25	White 1-19 - High Byte White 1-19 - Low Byte	0 - 65535	0 - 100%	0	16 bit control of White LEDs from 0 to full

RGBW 16-Bit Group Modes

Table 20 provides DMX channel mapping of all DMX512 control values when the SL BEAM 300 FX LED Luminaire is operated in various RGBW 16-bit DMX512 Group Control Modes.

Table 20: SL BEAM 300 FX LED Luminaire DMX Channel Mapping (RGBW 16-Bit Group Modes)

DMX CHANNEL	RGBW 8 bit mode	
	19 Group Mode	1 Group Mode
1	Pan - High Byte	Pan - High Byte
2	Pan - Low Byte	Pan - Low Byte
3	Tilt - High Byte	Tilt - High Byte
4	Tilt - Low Byte	Tilt - Low Byte
5	Master Intensity - High	Master Intensity - High
6	Master Intensity - Low	Master Intensity - Low
7	Color Presets	Color Presets
8	Strobe	Strobe
9	Duration	Duration
10	Zoom	Zoom
11	Rotate Mode	Rotate Mode
12	Position/Speed	Position/Speed
13	Focus Timing	Focus Timing
14	Intensity Timing	Intensity Timing
15	Color Timing	Color Timing
16	Zoom Timing	Zoom Timing
17	Control	Control
18	Red_1 - High Byte	Red_1-19 - High Byte
19	Red_1 - Low Byte	Red_1-19 - Low Byte
20	Green_1 - High Byte	Green_1-19 - High Byte
21	Green_1 - Low Byte	Green_1-19 - Low Byte
22	Blue_1 - High Byte	Blue_1-19 - High Byte
23	Blue_1 - Low Byte	Blue_1-19 - Low Byte
24	White_1 - High Byte	White_1-19 - High Byte
25	White_1 - Low Byte	White_1-19 - Low Byte
26	Red_2 - High Byte	
27	Red_2 - Low Byte	
28	Green_2 - High Byte	
29	Green_2 - Low Byte	
30	Blue_2 - High Byte	
31	Blue_2 - Low Byte	
32	White_2 - High Byte	
33	White_2 - Low Byte	
34	Red_3 - High Byte	
35	Red_3 - Low Byte	
36	Green_3 - High Byte	
37	Green_3 - Low Byte	
38	Blue_3 - High Byte	
39	Blue_3 - Low Byte	
40	White_3 - High Byte	
41	White_3 - Low Byte	
42	Red_4 - High Byte	
43	Red_4 - Low Byte	
44	Green_4 - High Byte	
45	Green_4 - Low Byte	
46	Blue_4 - High Byte	
47	Blue_4 - Low Byte	
48	White_4 - High Byte	
49	White_4 - Low Byte	
50	Red_5 - High Byte	
51	Red_5 - Low Byte	
52	Green_5 - High Byte	
53	Green_5 - Low Byte	
54	Blue_5 - High Byte	
55	Blue_5 - Low Byte	
56	White_5 - High Byte	
57	White_5 - Low Byte	
58	Red_6 - High Byte	
59	Red_6 - Low Byte	
60	Green_6 - High Byte	
61	Green_6 - Low Byte	
62	Blue_6 - High Byte	
63	Blue_6 - Low Byte	
64	White_6 - High Byte	
65	White_6 - Low Byte	
66	Red_7 - High Byte	
67	Red_7 - Low Byte	
68	Green_7 - High Byte	
69	Green_7 - Low Byte	
70	Blue_7 - High Byte	
71	Blue_7 - Low Byte	
72	White_7 - High Byte	
73	White_7 - Low Byte	
74	Red_8 - High Byte	
75	Red_8 - Low Byte	
76	Green_8 - High Byte	
77	Green_8 - Low Byte	
78	Blue_8 - High Byte	
79	Blue_8 - Low Byte	
80	White_8 - High Byte	
81	White_8 - Low Byte	
82		Red_9 - High Byte
83		Red_9 - Low Byte
84		Green_9 - High Byte
85		Green_9 - Low Byte
86		Blue_9 - High Byte
87		Blue_9 - Low Byte
88		White_9 - High Byte
89		White_9 - Low Byte
90		Red_10 - High Byte
91		Red_10 - Low Byte
92		Green_10 - High Byte
93		Green_10 - Low Byte
94		Blue_10 - High Byte
95		Blue_10 - Low Byte
96		White_10 - High Byte
97		White_10 - Low Byte
98		Red_11 - High Byte
99		Red_11 - Low Byte
100		Green_11 - High Byte
101		Green_11 - Low Byte
102		Blue_11 - High Byte
103		Blue_11 - Low Byte
104		White_11 - High Byte
105		White_11 - Low Byte
106		Red_12 - High Byte
107		Red_12 - Low Byte
108		Green_12 - High Byte
109		Green_12 - Low Byte
110		Blue_12 - High Byte
111		Blue_12 - Low Byte
112		White_12 - High Byte
113		White_12 - Low Byte
114		Red_13 - High Byte
115		Red_13 - Low Byte
116		Green_13 - High Byte
117		Green_13 - Low Byte
118		Blue_13 - High Byte
119		Blue_13 - Low Byte
120		White_13 - High Byte
121		White_13 - Low Byte
122		Red_14 - High Byte
123		Red_14 - Low Byte
124		Green_14 - High Byte
125		Green_14 - Low Byte
126		Blue_14 - High Byte
127		Blue_14 - Low Byte
128		White_14 - High Byte
129		White_14 - Low Byte
130		Red_15 - High Byte
131		Red_15 - Low Byte
132		Green_15 - High Byte
133		Green_15 - Low Byte
134		Blue_15 - High Byte
135		Blue_15 - Low Byte
136		White_15 - High Byte
137		White_15 - Low Byte
138		Red_16 - High Byte
139		Red_16 - Low Byte
140		Green_16 - High Byte
141		Green_16 - Low Byte
142		Blue_16 - High Byte
143		Blue_16 - Low Byte
144		White_16 - High Byte
145		White_16 - Low Byte
146		Red_17 - High Byte
147		Red_17 - Low Byte
148		Green_17 - High Byte
149		Green_17 - Low Byte
150		Blue_17 - High Byte
151		Blue_17 - Low Byte
152		White_17 - High Byte
153		White_17 - Low Byte
154		Red_18 - High Byte
155		Red_18 - Low Byte
156		Green_18 - High Byte
157		Green_18 - Low Byte
158		Blue_18 - High Byte
159		Blue_18 - Low Byte
160		White_18 - High Byte
161		White_18 - Low Byte
162		Red_19 - High Byte
163		Red_19 - Low Byte
164		Green_19 - High Byte
165		Green_19 - Low Byte
166		Blue_19 - High Byte
167		Blue_19 - Low Byte
168		White_19 - High Byte
169		White_19 - Low Byte

HSIC Mode

Table 21 provides DMX channel mapping of all DMX512 control values when the SL BEAM 300 FX LED Luminaire is in HSIC (Hue, Saturation, Intensity, and Color Correction) DMX512 mode (as set by the luminaire's menu system).

Table 21: SL BEAM 300 FX LED Luminaire DMX Channel Mapping (HSIC Mode)

DMX Channel	Parameter	Range DMX	Range%	Default	Description
1 2	Pan - High Byte Pan - Low Byte	0-65535	0-100%	32768	16-bit control of Pan
3 4	Tilt - High Byte Tilt - Low Byte	0-65535	0-100%	32768	16-bit control of Tilt
5	Master Intensity	0-255	0-100%	0	8 bit control of Intensity of LED settings
6	Strobe	0-255	0-100%	0	Controls strobe operations as follows . . . Open = DMX 0 - 2 Closed = DMX 3 - 5 Slow Rand = DMX 6 - 7 Med Rand = DMX 8 - 10 Fast Rand = DMX 11 - 12 Strobe Range = DMX 13 - 127 (fastest) Pulse + Slow Rand = DMX 128 - 129 Pulse + Med Rand = DMX 130 - 131 Pulse + Fast Rand = DMX 132 - 133 Pulse + Range = DMX 134 - 191 Pulse - Slow Rand = DMX 192 - 193 Pulse - Med Rand = DMX 194 - 195 Pulse - Fast Rand = DMX 196 - 197 Pulse - Range = DMX 198 - 255
7	Duration	0-255	0-100%	0	Strobe's duration, Range is 0-85 0 = DMX 0 1 = DMX 1 - 3 x = (DMX Value-1)/3+1 85 = DMX 253-255
8	Zoom	0-255	0-100%	0	Variable control of zoom from 55°-5°
9	Rotate Mode	0-255	0-100%	0	0-5% =DMX 0-14 OFF (Action same as Home) 6%-36% =DMX 15-93 Spin Mode 37%-67% =DMX 94-172 Index Mode 68%-100% =DMX 173-225 Reserved for future use
10	Position/Speed	0-255	0-100%	127	Spin Mode: 49%-51% Home 52% - 100%: Spin Speed Clockwise 48% - 0 : Spin Speed Counter Clockwise Index Mode: 49% - 51% Home 0 Degree 52%-100% Index Clockwise Home 0 degree to +180 degrees 48% - 0 Spin Index Counter Clockwise Home 0-180degrees
11	Focus Timing	0-255	0-100%	255	Timing Control of Pan/Tilt
12	Timing	0-255	0-100%	255	Allows for timing control of intensity. Channel should default to 255 for smoothest actions using console and/or manual fades. - See Timing chart for more details.
13	Control	0-255	0-100%	0	Set control channel value to desired action, hold value for at least 5 seconds, then turn to 0. Set control channel value to 0 without any scaling. Default Setting on Console =DMX 0-4 DIM Response_Normal =DMX 5-9 DIM Response_Incandescent =DMX 10-14 Dimming Curve_linear =DMX 30-34 Dimming Curve_Square =DMX 35-39 Dimming Curve_S-Curve =DMX 40-44 Dimming Curve_PL-Curve =DMX 45-49 Calibration_OFF =DMX 70-74 Calibration_ON =DMX 75-79 Fan_Auto =DMX 80-84 Fan_Off =DMX 85-89 Reserves(Future Use) =DMX 90-250
14 15	Hue1-19 - High Byte Hue1-19 - Low Byte	0-65535	0-100%	0	16 bit control of Hue 0-359°
16	Saturation1-19	0-255	0-100%	0	8 bit control of Saturation
17	Intensity1-19	0-255	0-100%	0	8 bit control of Intensity
18	CCT1-19	0-255	0-100%	0	Variable control of correlated color temperature from Channel OFF (disabled) DMX 0 - 5 2700K - 6500K. DMX 6 - 255

HSIC Group Modes

Table 22 provides DMX channel mapping of all DMX512 control values when the SL BEAM 300 FX LED Luminaire is operated in various HSIC DMX512 Group Control Modes.

Table 22: SL BEAM 300 FX LED Luminaire DMX Channel Mapping (HSIC Group Modes)

HSIC MODE		
DMX CHANNEL	19 Group MODE	1 Group MODE
1	Pan - High Byte	Pan - High Byte
2	Pan - Low Byte	Pan - Low Byte
3	Tilt - High Byte	Tilt - High Byte
4	Tilt - Low Byte	Tilt - Low Byte
5	Master Intensity	Master Intensity
6	Strobe	Strobe
7	Duration	Duration
8	Zoom	Zoom
9	Rotate Mode	Rotate Mode
10	Position/Speed	Position/Speed
11	Focus Timing	Focus Timing
12	Timing	Timing
13	Control	Control
14	Hue 1 - High Byte	Hue 1-19 - High Byte
15	Hue 1 - Low Byte	Hue 1-19 - Low Byte
16	Saturation 1	Saturation 1-19
17	Intensity 1	Intensity 1-19
18	CCT 1	CCT 1-19
19	Hue 2 - High Byte	
20	Hue 2 - Low Byte	
21	Saturation 2	
22	Intensity 2	
23	CCT 2	
24	Hue 3 - High Byte	
25	Hue 3 - Low Byte	
26	Saturation 3	
27	Intensity 3	
28	CCT 3	
29	Hue 4 - High Byte	
30	Hue 4 - Low Byte	
31	Saturation 4	
32	Intensity 4	
33	CCT 4	
34	Hue 5 - High Byte	
35	Hue 5 - Low Byte	
36	Saturation 5	
37	Intensity 5	
38	CCT 5	
39	Hue 6 - High Byte	
40	Hue 6 - Low Byte	
41	Saturation 6	
42	Intensity 6	
43	CCT 6	
44	Hue 7 - High Byte	
45	Hue 7 - Low Byte	
46	Saturation 7	
47	Intensity 7	
48	CCT 7	
49	Hue 8 - High Byte	
50	Hue 8 - Low Byte	
51	Saturation 8	
52	Intensity 8	
53	CCT 8	
54	Hue 9 - High Byte	
55	Hue 9 - Low Byte	
56	Saturation 9	
57	Intensity 9	
58	CCT 9	
59	Hue 10 - High Byte	
60	Hue 10 - Low Byte	
61	Saturation 10	
62	Intensity 10	
63	CCT 10	
64	Hue 11 - High Byte	
65	Hue 11 - Low Byte	
66	Saturation 11	
67	Intensity 11	
68	CCT 11	
69	Hue 12 - High Byte	
70	Hue 12 - Low Byte	
71	Saturation 12	
72	Intensity 12	
73	CCT 12	
74	Hue 13 - High Byte	
75	Hue 13 - Low Byte	
76	Saturation 13	
77	Intensity 13	
78	CCT 13	
79	Hue 14 - High Byte	
80	Hue 14 - Low Byte	
81	Saturation 14	
82	Intensity 14	
83	CCT 14	
84	Hue 15 - High Byte	
85	Hue 15 - Low Byte	
86	Saturation 15	
87	Intensity 15	
88	CCT 15	
89	Hue 16 - High Byte	
90	Hue 16 - Low Byte	
91	Saturation 16	
92	Intensity 16	
93	CCT 16	
94	Hue 17 - High Byte	
95	Hue 17 - Low Byte	
96	Saturation 17	
97	Intensity 17	
98	CCT 17	
99	Hue 18 - High Byte	
100	Hue 18 - Low Byte	
101	Saturation 18	
102	Intensity 18	
103	CCT 18	
104	Hue 19 - High Byte	
105	Hue 19 - Low Byte	
106	Saturation 19	
107	Intensity 19	
108	CCT 19	

Pattern Mode

Table 23 provides DMX channel mapping of all DMX512 control values when the SL BEAM 300 FX LED Luminaire is in Pattern mode (as set by the luminaire's menu system). For a lists of Pattern effects, refer to the appendix.

Table 23: SL BEAM 300 FX LED Luminaire DMX Channel Mapping (Pattern Mode)

DMX Channel	Parameter	Range DMX	Range%	Default	Description
1 2	Pan - High Byte Pan - Low Byte	0 - 65535	0 - 100%	32768	16 bit control of Pan
3 4	Tilt - High Byte Tilt - Low Byte	0 - 65535	0 - 100%	32768	16 bit control of Tilt
5 6	Master Intensity - High Master Intensity - Low	0 - 65535	0 - 100%	0	16 bit control for Intensity of LED settings.
7	Color Presets	0 - 255	0 - 100%	0	Variable color Presets as follows . . . Channel OFF (disabled) DMX 0 - 4 Preset 0 (OFF) DMX 5 - 6 Preset 1 DMX 7 - 8 Preset 2 DMX 9 - 10 Preset 3 DMX 11 - 12 Preset 4 DMX 13 - 14 Preset 5 DMX 15 - 16 Preset 6 DMX 17 - 18 Preset 7 DMX 19 - 20 Preset 8 DMX 21 - 22 Preset 9 DMX 23 - 24 Preset 10 DMX 25 - 26 Preset 11 DMX 27 - 28 Preset 12 DMX 29 - 30 Preset 13 DMX 31 - 32 Preset 14 DMX 33 - 34 Preset 15 DMX 35 - 36 Preset 16 DMX 37 - 38 Preset 17 DMX 39 - 40 Preset 18 DMX 41 - 42 Preset 19 DMX 43 - 44 Preset 20 DMX 45 - 46 Preset 21 DMX 47 - 48 Preset 22 DMX 49 - 50 Preset 23 DMX 51 - 52 Preset 24 DMX 53 - 54 Preset 25 DMX 55 - 56 Preset 26 DMX 57 - 58 Preset 27 DMX 59 - 60 Preset 28 DMX 61 - 62 Preset 29 DMX 63 - 64 Preset 30 DMX 65 - 66 Preset 31 DMX 67 - 68 CF_0_Color OFF DMX 69 - 70 CF_1_White 1000K DMX 71 - 72 CF_2_White 8000K DMX 73 - 74 CF_3_White 6500K DMX 75 - 76 CF_4_White 5600K DMX 77 - 78 CF_5_White 5000K DMX 79 - 80 CF_6_White 4500K DMX 81 - 82 CF_7_White 4000K DMX 83 - 84 CF_8_White 3200K DMX 85 - 86 CF_9_White 3000K DMX 87 - 88 CF_10_White 2700K DMX 89 - 90

Table 23: SL BEAM 300 FX LED Luminaire DMX Channel Mapping (Pattern Mode)

DMX Channel	Parameter	Range DMX	Range%	Default	Description
7	Color Presets	0 - 255	0 - 100%	0	CF_11_Moroccan Pink DMX 91 - 92
					CF_12_Pink DMX 93 - 94
					CF_13_Flesh Pink DMX 95 - 96
					CF_14_Bright Rose DMX 97 - 98
					CF_15_Follies Pink DMX 99 - 100
					CF_16_Fuchsia Pink DMX 101 - 102
					CF_17_Surprise Pink DMX 103 - 104
					CF_18_Congo Blue DMX 105 - 106
					CF_19_Blue DMX 107 - 108
					CF_20_Virgin Blue DMX 109 - 110
					CF_21_Midnight Maya DMX 111 - 112
					CF_22_Double C.T Blue DMX 113-114
					CF_23_Slate Blue DMX 115 - 116
					CF_24_Regal Blue DMX 117 - 118
					CF_25_Full C.T Blue DMX 119-120
					CF_26_Steel Blue DMX 121 - 122
					CF_27_Lighter Blue DMX 123 - 124
					CF_28_Cyan DMX 125 - 126
					CF_29_Marine Blue DMX 127 - 128
					CF_30_Soft Green DMX 129 - 130
					CF_31_Moss Green DMX 131 - 132
					CF_32_Green DMX 133 - 134
					CF_33_Fem Green DMX 135 - 136
					CF_34_JAS Green DMX 137 - 138
					CF_35_Pale Green DMX 139 - 140
					CF_36_Spring Yellow DMX 141 - 142
					CF_37_Yellow DMX 143 - 144
					CF_38_Deep Amber DMX 145 - 146
					CF_39_Chrome Orange DMX 147 - 148
					CF_40_Orange DMX 149 - 150
					CF_41_Magenta DMX 151 - 152
					CF_42_Flame Red DMX 153 - 154
					CF_43_Purple DMX 155 - 156
					Rotate CW Fast→Slow DMX 157 - 171
					Rotate ACW Slow→Fast DMX 172 - 186
					Random Color Fast→Slow DMX 187 - 201
					Chase1 DMX 202 - 204
					Chase2 DMX 205 - 207
					Chase3 DMX 208 - 210
					Chase4 DMX 211 - 213
					Chase5 DMX 214 - 216
					Chase6 DMX 217 - 219
					Chase7 DMX 220 - 222
Chase8 DMX 223 - 225					
Chase9 DMX 226 - 228					
Chase10 DMX 229 - 231					
User Chase1 DMX 232 - 234					
User Chase2 DMX 235 - 237					
User Chase3 DMX 238 - 240					
User Chase4 DMX 241 - 243					
User Chase5 DMX 244 - 246					
User Chase6 DMX 247 - 249					
User Chase7 DMX 250 - 252					
User Chase8 DMX 253 - 255					

Table 23: SL BEAM 300 FX LED Luminaire DMX Channel Mapping (Pattern Mode)

DMX	Parameter	Range DMX	Range%	Defaults	Description
8	Strobe	0-255	0-100%	0	Pulse + Slow Rand = DMX 128 - 129 Pulse + Med Rand = DMX 130 - 131 Pulse + Fast Rand = DMX 132 - 133 Pulse + Range = DMX 134 - 191 Pulse - Slow Rand = DMX 192 - 193 Pulse - Med Rand = DMX 194 - 195 Pulse - Fast Rand = DMX 196 - 197 Pulse - Range = DMX 198 - 255
9	Duration	0-255	0-100%	0	Strobe's duration Range is 0-85 0 DMX0 1 DMX 1-3 x (DMX Value-1)/3+1 85 DMX253-255
10	Zoom	0-255	0-100%	0	Variable control of zoom from 55°-5°
11	Rotate Mode	0-255	0-100%	0	0-5% =DMX 0-14 OFF (Action same as Home) 6%-36% =DMX 15-93 Spin Mode 37%-67% =DMX 94-172 Index Mode 68%-100% =DMX 173-225 Reserved for future use
12	Position/Speed	0-255	0-100%	0	Spin Mode: 49%-51% Home 52% - 100%: Spin Speed Clockwise 48% - 0 : Spin Speed Counter Clockwise Index Mode: 49% - 51% Home 0 Degree 52%-100% Index Clockwise Home 0 degree to +180 degrees 48% - 0 Spin Index Counter Clockwise Home 0-180degrees
13	Focus Timing	0-255	0-100%	255	Timing control of Pan/Tilt
14	Intensity Timing	0-255	0-100%	255	Allows for timing control of intensity. Channel should default to 255 for smoothest actions using console and/or manual fades. - See Timing chart for more details.
15	Color Timing	0-255	0-100%	255	Allows for timing control of color. Channel should default to 255 for smoothest actions using console and/or manual fades. - See Timing chart for more details.
16	Zoom Timing	0-255	0-100%	255	Allows for timing control of zoom
17	Control	0-255	0-100%	0	Set control channel value to desired action, hold value for at least 5 seconds, then turn to 0. Set control channel value to 0 without any scaling. Default Setting on Console DIM Response_Normal =DMX 0-4 DIM Response_Incandescent =DMX 5-9 Dimming Curve_linear =DMX 10-14 Dimming Curve_Square =DMX 30-34 Dimming Curve_S-Curve =DMX 35-39 Dimming Curve_PL-Curve =DMX 40-44 Calibration_OFF =DMX 45-49 Calibration_ON =DMX 70-74 Fan_Auto =DMX 75-79 Fan_Off =DMX 80-84 Reserved(Future Use) =DMX 85-89 =DMX 90-250
18	Pattern	0-255	0-100%	0	Pattern Select DMX0-5 Pattern disable DMX5-255 Pattern 1-32
19	Pattern Step	0-255	0-100%	0	Pattern Step DMX0-5 No used DMX6-200 Pattern step select DMX201-255 Pattern running speed 2s-0
20	Red1-19 - High Byte	0-65535	0-100%	0	16 bit control of Red LEDs from 0 to full
21	Red1-19 - Low Byte				
22	Green1-19 - High Byte	0-65535	0-100%	0	16 bit control of Green LEDs from 0 to full
23	Green1-19 - Low Byte				
24	Blue1-19 - High Byte	0-65535	0-100%	0	16 bit control of Blue LEDs from 0 to full
25	Blue1-19 - Low Byte				
26	White1-19 - High Byte	0-65535	0-100%	0	16 bit control of White LEDs from 0 to full
27	White1-19 - Low Byte				

Pattern Group Modes

Table 24 provides DMX channel mapping of all DMX512 control values when the SL BEAM 300 FX LED Luminaire is operated in various Pattern DMX512 Group Control Modes.

Table 24: SL BEAM 300 FX LED Luminaire DMX Channel Mapping (Pattern Group Modes)

Pattern Mode	
DMX CHANNEL	x Group Mode
1	Pan - High Byte
2	Pan - Low Byte
3	Tilt - High Byte
4	Tilt - Low Byte
5	Master Intensity - High
6	Master Intensity - Low
7	Color Presets
8	Strobe
9	Duration
10	Zoom
11	Rotate Mode
12	Position / Speed
13	Focus Timing
14	Intensity Timing
15	Color Timing
16	Zoom Timing
17	Control
18	Pattern
19	Pattern Step
20	Red_1-19 - High Byte
21	Red_1-19 - Low Byte
22	Red_1-19 - High Byte
23	Red_1-19 - Low Byte
24	Red_1-19 - High Byte
25	Red_1-19 - Low Byte
26	Red_1-19 - High Byte
27	Red_1-19 - Low Byte

2. DMX Timing Channel Detail

Timing channel control improves the timed moves of certain groups of parameters. The SL BEAM 300 FX LED Luminaire provides timing channels in 16-bit mode (one for intensity time and one for color time) and one timing channel in 8-bit (color and intensity timing combined). The luminaire uses its timing channel value to calculate a smooth continuous operation for a given time and transition.

Guidelines:

- Timing channels support time values from zero to 60 minutes.
- To use a timing channel instead of console timing, it is recommended to set the timing channel to the desired value and set cue and/or console cue fade time to zero. A combination of time controls can produce unexpected results.
- The default value setting in the profile should be 255 (proportional control) to allow smooth operation when using console timing.
- The timing channel data should change as a snap. A zero value will give the fastest operation, however, without any smoothing this can appear "steppy" in console timed moves.

Refer to "DMX Timing Channel Detail" for more information.

Table 25: SL BEAM 300 FX LED Luminaire Timing Channel Detail

% Value	DMX	= Seconds <i>(unless noted)</i>
0	0	0 (Full Speed)
	1	0.2
	2	0.4
1	3	0.6
	4	0.8
2	5	1
	6	1.2
	7	1.4
3	8	1.6

Table 25: SL BEAM 300 FX LED Luminaire Timing Channel Detail

% Value	DMX	= Seconds (unless noted)
	9	1.8
4	10	2
	11	2.2
	12	2.4
5	13	2.6
	14	2.8
6	15	3
	16	3.2
	17	3.4
7	18	3.6
	19	3.8
8	20	4
	21	4.2
	22	4.4
9	23	4.6
	24	4.8
10	25	5
	26	5.2
	27	5.4
11	28	5.6
	29	5.8
	30	6
12	31	6.2
	32	6.4
13	33	6.6
	34	6.8
	35	7
14	36	7.2
	37	7.4
15	38	7.6
	39	7.8
	40	8
16	41	8.2
	42	8.4
17	43	8.6
	44	8.8
	45	9
18	46	9.2
	47	9.4
19	48	9.6
	49	9.8
	50	10
20	51	10.2
	52	10.4
	53	10.6
21	54	10.8
	55	11
22	56	11.2
	57	11.4
	58	11.6
23	59	11.8

Table 25: SL BEAM 300 FX LED Luminaire Timing Channel Detail

% Value	DMX	= Seconds (unless noted)
	60	12
24	61	12.2
	62	12.4
	63	12.6
25	64	12.8
	65	13
26	66	13.2
	67	13.4
	68	13.6
27	69	13.8
	70	14
28	71	14.2
	72	14.4
	73	14.6
29	74	14.8
	75	15
30	76	15.2
	77	15.4
	78	15.6
31	79	15.8
	80	16
	81	16.2
32	82	16.4
	83	16.6
33	84	16.8
	85	17
	86	17.2
34	87	17.4
	88	17.6
35	89	17.8
	90	18
	91	18.2
36	92	18.4
	93	18.6
37	94	18.6
	95	19
	96	19.2
38	97	19.4
	98	19.6
39	99	19.8
	100	20
	101	21
40	102	22
	103	23
	104	24
41	105	25
	106	26
42	107	27
	108	28
	109	29
43	110	30

Table 25: SL BEAM 300 FX LED Luminaire Timing Channel Detail

% Value	DMX	= Seconds (unless noted)
	111	31
44	112	32
	113	33
	114	34
45	115	35
	116	36
46	117	37
	118	38
	119	39
47	120	40
	121	41
48	122	42
	123	43
	124	44
49	125	45
	126	46
	127	47
50	128	48
	129	49
51	130	50
	131	51
	132	52
52	133	53
	134	54
53	135	55
	136	56
	137	57
54	138	58
	139	59
55	140	60
	141	61
	142	62
56	143	63
	144	64
57	145	65
	146	66
	147	67
58	148	68
	149	69
59	150	70
	151	71
	152	72
60	153	73
	154	74
	155	75
61	156	76
	157	77
62	158	78
	159	79
	160	80
63	161	81

Table 25: SL BEAM 300 FX LED Luminaire Timing Channel Detail

% Value	DMX	= Seconds (unless noted)
	162	82
64	163	83
	164	84
	165	85
65	166	86
	167	87
66	168	88
	169	89
	170	90
67	171	91
	172	92
68	173	93
	174	94
	175	95
69	176	96
	177	97
	178	98
70	179	99
	180	100
71	181	101
	182	102
	183	103
72	184	104
	185	105
73	186	106
	187	107
	188	108
74	189	109
	190	110
75	191	111
	192	112
	193	113
76	194	114
	195	115
77	196	116
	197	117
	198	118
78	199	119
	200	120
79	201	121
	202	122
	203	123
80	204	124
	205	125
81	206	126
	207	127
	208	128
82	209	129
	210	130
	211	131
83	212	132

Table 25: SL BEAM 300 FX Luminaire Timing Channel Detail

% Value	DMX	= Seconds (unless noted)
	213	133
84	214	134
	215	135
	216	136
85	217	137
	218	138
86	219	139
	220	140
	221	141
87	222	142
	223	143
88	224	144
	225	145
	226	146
89	227	147
	228	148
	229	149
90	230	150
	231	151
91	232	152
	233	153
	234	154
92	235	155
	236	156
93	237	157
	238	158
	239	159
94	240	160
	241	161
95	242	162
	243	163
	244	164
96	245	165
	246	5 Minutes
97	247	15 Minutes
	248	30 Minutes
	249	60 Minutes
98	250*	60mS
	251*	80mS
99	252*	100mS
	253*	120mS
	254*	140mS
100	255* (Default)	160mS

Note: DMX values 250 to 255 provide smoothing when using console fade timing. DMX value 255(recommended default) will provide the smoothest timing.

RDM PARAMETER IDS

1. SL BEAM 300 FX LED Luminaire RDM Parameter IDs

The following tables outline and describe all the RDM parameters IDs associated with SL BEAM 300 FX LED Luminaires.

- [Table 26, “SL BEAM 300 FX LED Luminaire RDM Product Parameters IDs”](#)
- [Table 27, “SL BEAM 300 FX LED Luminaire RDM UID”](#)
- [Table 28, “SL BEAM 300 FX LED Luminaire RDM Parameters IDs”](#)
- [Table 29, “SL BEAM 300 FX LED Luminaire RDM Manufacturer IDs” on page 34](#)
- [Table 30, “SL BEAM 300 FX LED Luminaire RDM Manufacturer Specific PIDs” on page 34](#)
- [Table 31, “SL BEAM 300 FX LED Luminaire RDM Manufacturer Specific PIDs for sub device” on page 34](#)

Table 26: SL BEAM 300 FX LED Luminaire RDM Product Parameters IDs

Model ID	Manufacturer	Model Description	Product Category
0x1228	Philips Entertain. Lighting Asia	SL BEAM 300FX (RGBW)	0x0509

Table 27: SL BEAM 300 FX LED Luminaire RDM UID

UID					
MSB of ESTA 50H	LSB of ESTA 41H	1st of Unique Seq	2nd of Unique Seq	3rd of Unique Seq	4th of Unique Seq

Table 28: SL BEAM 300 FX LED Luminaire RDM Parameters IDs

Get Allowed	Set Allowed	RDM Parameter IDs	Value	Comment	Implemented
<i>Category - Network Management</i>					
		DISC_UNIQUE_BRANCH	0x0001		■
		DISC_MUTE	0x0002		■
		DISC_UN_MUTE	0x0003		■
■		PROXIED_DEVICES	0x0010		
■		PROXIED_DEVICES_COUNT	0x0011		
■	■	COMMS_STATUS	0x0015		
<i>Category - Status Collection</i>					
■		QUEUED_MESSAGE	0x0020		■
■		STATUS_MESSAGES	0x0030		■
■		STATUS_ID_DESCRIPTION	0x0031		■
	■	CLEAR_STATUS_ID	0x0032		■
■	■	SUB_DEVICE_STATUS_REPORT_THRESHOLD	0x0033		
<i>Category - RDM Information</i>					
■		SUPPORTED_PARAMETERS	0x0050	Support required only if supporting Parameters beyond the minimum required set.	■
■		PARAMETER_DESCRIPTION	0x0051	Support required for Manufacturer-Specific PIDs exposed in SUPPORTED_PARAMETERS message.	■

Table 28: SL BEAM 300 FX LED Luminaire RDM Parameters IDs

Get Allowed	Set Allowed	RDM Parameter IDs	Value	Comment	Implemented
<i>Category - Product Information</i>					
■		DEVICE_INFO	0x0060		■
■		PRODUCT_DETAIL_ID_LIST	0x0070		
■		DEVICE_MODEL_DESCRIPTION	0x0080		■
■		MANUFACTURER_LABEL	0x0081		■
■	■	DEVICE_LABEL	0x0082		■
■	■	FACTORY_DEFAULTS	0x0090		■
■		LANGUAGE_CAPABILITIES	0x00A0		
■	■	LANGUAGE	0x00B0		
■		SOFTWARE_VERSION_LABEL	0x00C0		■
■		BOOT_SOFTWARE_VERSION_ID	0x00C1		
■		BOOT_SOFTWARE_VERSION_LABEL	0x00C2		
<i>Category - DMX512 Setup</i>					
■	■	DMX_PERSONALITY	0x00E0		■
■		DMX_PERSONALITY_DESCRIPTION	0x00E1		■
■	■	DMX_START_ADDRESS	0x00F0	Required if device uses a DMX Slot	■
■		SLOT_INFO	0x0120		■
■		SLOT_DESCRIPTION	0x0121		■
■		DEFAULT_SLOT_VALUE	0x0122		
<i>Category - Sensors 0x02xx</i>					
■		SENSOR_DEFINITION	0x0200		■
■	■	SENSOR_VALUE	0x0201		■
	■	RECORD_SENSORS	0x0202		
<i>Category - Dimmer Settings 0x03xx - FUTURE USE</i>					
<i>Category - Power / Lamp Settings 0x04xx</i>					
■	■	DEVICE_HOURS	0x0400		
■	■	LAMP_HOURS	0x0401		
■	■	LAMP_STRIKES	0x0402		
■	■	LAMP_STATE	0x0403		
■	■	LAMP_ON_MODE	0x0404		
■	■	DEVICE_POWER_CYCLES	0x0405		
<i>Category - Display Settings 0x05xx</i>					
■	■	DISPLAY_INVERT	0x0500		■
■	■	DISPLAY_LEVEL	0x0501		
<i>Category - Configuration 0x06xx</i>					
■	■	PAN_INVERT	0x0600		
■	■	TILT_INVERT	0x0601		
■	■	PAN_TILT_SWAP	0x0602		
■	■	REAL_TIME_CLOCK	0x0603		
<i>Category - Control 0x10xx</i>					
■	■	IDENTIFY_DEVICE	0x1000		■
	■	RESET_DEVICE	0x1001		

Table 28: SL BEAM 300 FX LED Luminaire RDM Parameters IDs

Get Allowed	Set Allowed	RDM Parameter IDs	Value	Comment	Implemented
■	■	POWER_STATE	0x1010		
■	■	PERFORM_SELFTEST	0x1020		
■		SELF_TEST_DESCRIPTION	0x1021		
	■	CAPTURE_PRESET	0x1030		
■	■	PRESET_PLAYBACK	0x1031		

Table 29: SL BEAM 300 FX LED Luminaire RDM Parameter Status IDs

Manufacturer Specific messages are in the range of 0x8000 - 0xFFDF. Each Manufacturer-specific Status ID shall have a unique meaning, which shall be consistent across all products having a given Manufacturer ID. See Table B-2, ANSI E1.20-2010				
Status ID Message	Value	Data Value 1	Data Value 2	Status ID Description
8100H		00H	00H	ALL OK

Table 30: SL BEAM 300 FX LED Luminaire RDM Parameter Specific PIDs

Get Allowed	Set Allowed	RDM Parameter IDs	Type	Length	Unit	Prefix	Min	Max	Default	Description
<i>Category - Manufacturer Defined PIDs - Range is 0x80000-0xffdf(See ANSI E1.20-2010 Standard, Table A-3)</i>										
■	■	8A00H	U8	1	NONE	NONE	0	100	100	DIMMER
■	■	8AB2H	U8	1	NONE	NONE	1	18	1	Chase
■	■	8AB0H	U8	1	NONE	NONE	0	43	0	Color Filter
■	■	8AB1H	U8	1	NONE	NONE	0	31	0	Preset
■	■	8A92H	U8	1	NONE	NONE	0	255	0	Strobe
■	■	8A94H	U8	1	NONE	NONE	0	255	0	Duration
■	■	8A95H	U16	1	NONE	NONE	0	65535	32768	Pan
■	■	8A96H	U16	1	NONE	NONE	0	65535	32768	Tilt
■	■	8A93H	U8	1	NONE	NONE	0	255	0	Zoom
■	■	8A97H	U8	1	NONE	NONE	0	1	0	Fan AUTO/OFF Setup
■	■	8AC0H	U8	1	NONE	NONE	0	255	255	Intensity Timing
■	■	8AC2H	U8	1	NONE	NONE	0	255	255	Color Timing
■	■	8A40H	U8	1	NONE	NONE	0	1	0	Link Mode
■	■	8A42H	U8	1	NONE	NONE	0	1	0	Incandescent Effect
■	■	8AA1H	U8	1	NONE	NONE	0	3	0	Dimming Curve
■	■	8A0CH	U8	1	NONE	NONE	0	3	0	DMX FAIL MODE
■	■	8AA0H	U8	1	NONE	NONE	0	4	0	Backlight Off time
■	■	8AA2H	U8	1	NONE	NONE	0	94	0	Power UP Setup
■	■	8A44H	U8	1	NONE	NONE	0	1	0	Calibration ON/OFF Setup
■	■	8A41H	U8	1	NONE	NONE	0	1	0	Lock Fixture
■	■	8AD3H	U8	1	NONE	NONE	0	1	0	PAN/TILT FEEDBACK

Table 31: SL BEAM 300 FX LED Luminaire RDM Parameter Specific PIDs for sub device

Get Allowed	Set Allowed	RDM Parameter IDs	Type	Length	Unit	Prefix	Min	Max	Default	Description
<i>Category - Manufacturer Specific PIDs for sub device - Range is 0x80000-0xffdf(See ANSI E1.20-2010 Standard, Table A-3)</i>										
■	■	8A04H	U8	1	NONE	NONE	0	100	100	Dimmer Red
■	■	8A05H	U8	1	NONE	NONE	0	100	100	Dimmer Green
■	■	8A06H	U8	1	NONE	NONE	0	100	100	Dimmer Blue
■	■	8A07H	U8	1	NONE	NONE	0	100	100	Dimmer White

CLEANING AND CARE



WARNING! All cleaning should be performed with power completely removed from the luminaire. Never remove protective covers when luminaire is powered. Wear appropriate protective eye wear and gloves when cleaning the fixture. All service and maintenance, other than described herein, should be performed by a qualified technician or Authorized Service Center.

1. Special Cleaning and Care Instructions

Being a solid-state fixture, and unlike most fixtures, the SL BEAM 300 FX LED Luminaire requires very little routine maintenance by the user. This section covers portions of the luminaire that can be removed for cleaning.

The SL BEAM 300 FX LED Luminaries requires special care when it comes to cleaning front lens assembly. Additional care needs to be taken with the plastic components because they are much easier to scratch or damage than glass. The following is a list of cleaning materials required to care for your SL BEAM 300 FX LED Luminaire:

- Lint free lens tissue
- Lint or powder free gloves
- Reagent grade isopropyl alcohol*
- A mild soap solution

Note: *Reagent grade isopropyl alcohol is good to use on the SL BEAM 300 FX LED Luminaire plastic optics with anti-reflection coatings.

If the lens is still dirty after using isopropyl alcohol, for instance if fingerprints or oil is just redistributed and not cleaned off the optic, then a mild soap and water solution can be used to gently wash the lens. Repeat the cleaning with isopropyl alcohol to eliminate streaks and soap residue.



WARNING! Under no circumstances should ammonia-based cleaners, acetone, or other harsh solvents be used on or near the SL BEAM 300 FX LED Luminaire. These types of cleaners or solvents can permanently damage the optics or housings of the fixture.

If you have any questions regarding the use or care of your SL BEAM 300 FX LED Luminaire, please contact Showline technical support or your local Authorized Dealer.

2. Front Lens Cleaning

To clean the front lens:

- Step 1. Turn off luminaire and allow to cool completely.
- Step 2. Apply a small amount of reagent grade isopropyl alcohol to lint-free lens tissue.
- Step 3. Wipe all debris, dirt, fingerprints, etc. from lens.
- Step 4. Using a second lint-free lens tissue, wipe off any alcohol residue.

3. Service and Maintenance

For all other service and maintenance issues, please contact your local Showline office or an Authorized Service Center.

TECHNICAL SPECIFICATIONS

1. Operational Specifications

Source:	19 Osram 4-in-1 RGBW LED Array
Zoom Range:	5-55 Degrees(4-40 degrees at 50% of max illumination)
Light Output:	4500 lumens
Color Temperature:	2700 - 6500K (user adjustable)
Input Voltage:	100V to 240V(+/- 10%, auto-ranging)
Power Consumption:	360 Watts(max).
Frequency:	50/60Hz
Control Protocols:	DMX512(1990) / DMX512A (RDM) / On-Board Menu
Ambient Temperature:	-20 to 40 Degrees C (-4 to 104 Degrees F)
Humidity:	5%-95% Non condensing
Cooling:	Forced Air Cooling
Weight:	14.5kg (31.9 lbs) - Luminaire only (no mount, AC input cable or accessories)
Housing:	Die Cast aluminium with Powder Coating
Pan:	540 degrees (end to end less than 2.5s)
Tilt:	230 degrees (end to end less than 1.5s)
Compliance:	CE / C-Tick marked and ETL listed
IP Rating:	IP20

Note: Common model specifications shown. For specific model specifications, features, and accessories, refer to the product specification sheet for more details.



2. Luminaire Dimensions

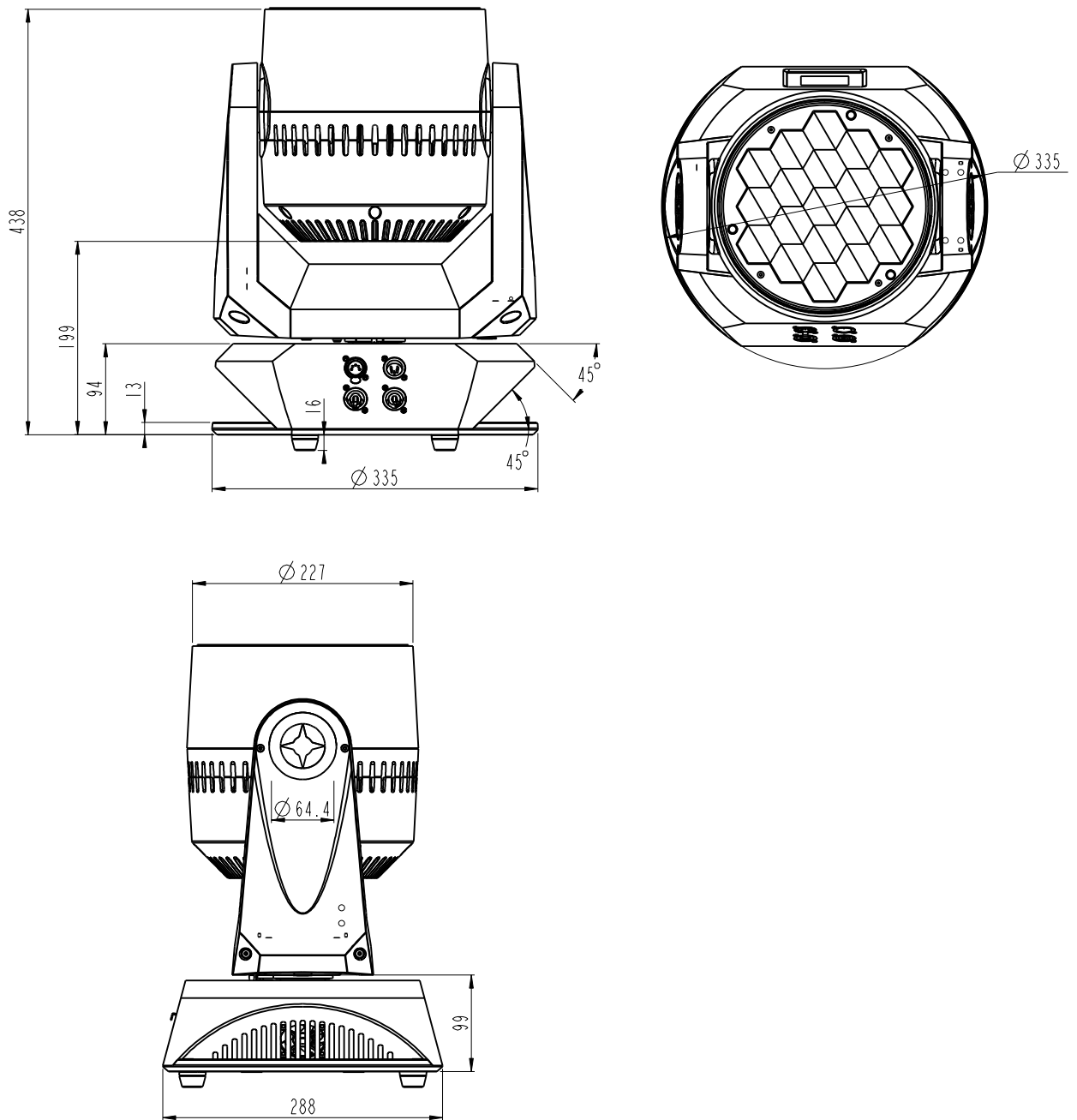

NOTE

Appendix

All patterns can be selected via external DMX/RDM console by their corresponding DMX value on Channel 18 and 19. DMX Channel 18 will select the pattern group and DMX Channel 19 will select an individual pattern. The combination of DMX channel 18 and 19 will locate the desired pattern precisely. Details are as below.

Orientation: Patterns are shown when looking at the front of a standing fixture; Head faced in direction of fixtures **front** label:DMX Pan @75, Tilt @230.

Channel 18	Channel 19	Pattern
5-12	5-20	
5-12	21-36	
5-12	37-52	
5-12	53-68	
5-12	69-84	
5-12	85-100	
5-12	101-116	
5-12	117-132	
5-12	133-148	
5-12	149-164	
5-12	165-180	
5-12	181	

Channel 18	Channel 19	Pattern
13-20	5-17	
13-20	18-30	
13-20	31-43	
13-20	44-56	
13-20	57-69	
13-20	70-82	
13-20	83-95	
13-20	96-108	
13-20	109-121	
13-20	122-134	
13-20	135-147	
13-20	148-160	
13-20	161-173	
13-20	174	

Channel 18	Channel 19	Pattern
21-28	5-36	
21-28	36-68	
21-28	69-100	
21-28	101-132	
21-28	133-164	
21-28	165	









Channel 18	Channel 19	Pattern
29-36	5-23	
29-36	24-42	
29-36	43-61	
29-36	62-80	
29-36	81-99	
29-36	100-118	
29-36	119-137	
29-36	138-156	
29-36	157-175	
29-36	176	







Channel 18	Channel 19	Pattern
37-44	5-16	
37-44	17-28	
37-44	29-40	
37-44	41-52	
37-44	53-64	
37-44	65-76	
37-44	77-88	
37-44	89-100	
37-44	101-112	
37-44	113-124	
37-44	125-136	
37-44	137-148	
37-44	149-160	
37-44	161-172	
37-44	173-184	
37-44	185	













Channel 18	Channel 19	Pattern
45-52	5-28	
45-52	29-52	
45-52	53-76	
45-52	77-100	
45-52	101-124	
45-52	125-148	
45-52	149-172	
45-52	173	





Channel 18	Channel 19	Pattern
53-60	5-23	
53-60	24-42	
53-60	43-61	
53-60	62-80	
53-60	81-99	
53-60	100-118	
53-60	119-137	
53-60	138-156	
53-60	157-175	
53-60	176	











Channel 18	Channel 19	Pattern
61-68	5-23	
61-68	24-42	
61-68	43-61	
61-68	62-80	
61-68	81-99	
61-68	100-118	
61-68	119-137	
61-68	138-156	
61-68	157-175	
61-68	176	

Channel 18	Channel 19	Pattern
69-76	5-28	
69-76	29-52	
69-76	53-76	
69-76	77-100	
69-76	101-124	
69-76	125-148	
69-76	149-172	
69-76	173	

Channel 18	Channel 19	Pattern
77-84	5-31	
77-84	32-58	
77-84	59-85	
77-84	86-112	
77-84	113-139	
77-84	140-166	
77-84	167	

Channel 18	Channel 19	Pattern
85-92	5-20	
85-92	21-36	
85-92	37-52	
85-92	53-68	
85-92	69-84	
85-92	85-100	
85-92	101-116	
85-92	117-132	
85-92	133-148	
85-92	149-164	
85-92	165-180	
85-92	181	

Channel 18	Channel 19	Pattern
93-100	5-43	
93-100	44-82	
93-100	83-121	
93-100	122-160	
93-100	161	

Channel 18	Channel 19	Pattern
101-108	5-23	
101-108	24-42	
101-108	43-61	
101-108	62-80	
101-108	81-99	
101-108	100-118	
101-108	119-137	
101-108	138-156	
101-108	157-175	
101-108	176	

Channel 18	Channel 19	Pattern
109-116	5-20	
109-116	21-36	
109-116	37-52	
109-116	53-68	
109-116	69-84	
109-116	85-100	
109-116	101-116	
109-116	117-132	
109-116	133-148	
109-116	149-164	
109-116	165-180	
109-116	181	

Channel 18	Channel 19	Pattern
117-124	5-16	
117-124	17-28	
117-124	29-40	
117-124	41-52	
117-124	53-64	
117-124	65-76	
117-124	77-88	
117-124	89-100	
117-124	101-112	
117-124	113-124	
117-124	125-136	
117-124	137-148	
117-124	149-160	
117-124	161-172	
117-124	173-184	
117-124	185	

Channel 18	Channel 19	Pattern
125-132	5-25	
125-132	26-46	
125-132	47-67	
125-132	68-88	
125-132	89-109	
125-132	110-130	
125-132	131-151	
125-132	152-172	
125-132	173	

Channel 18	Channel 19	Pattern
133-140	5-23	
133-140	24-42	
133-140	43-61	
133-140	62-80	
133-140	81-99	
133-140	100-118	
133-140	119-137	
133-140	138-156	
133-140	157-175	
133-140	176	

Channel 18	Channel 19	Pattern
141-148	5-28	
141-148	29-52	
141-148	53-76	
141-148	77-100	
141-148	101-124	
141-148	125-148	
141-148	149-172	
141-148	173	

Channel 18	Channel 19	Pattern
149-156	5-14	
149-156	15-24	
149-156	25-34	
149-156	35-44	
149-156	45-54	
149-156	55-64	
149-156	65-74	
149-156	75-84	
149-156	85-94	
149-156	95-104	
149-156	105-114	
149-156	115-124	
149-156	125-134	
149-156	135-144	
149-156	145-154	
149-156	155-164	
149-156	165-174	
149-156	175	

Channel 18	Channel 19	Pattern
157-164	5-14	
157-164	15-24	
157-164	25-34	
157-164	35-44	
157-164	45-54	
157-164	55-64	
157-164	65-74	
157-164	75-84	
157-164	85-94	
157-164	95-104	
157-164	105-114	
157-164	115-124	
157-164	125-134	
157-164	135-144	
157-164	145-154	
157-164	155-164	
157-164	165-174	
157-164	175-184	
157-164	185	

Channel 18	Channel 19	Pattern
165-172	5-25	
165-172	26-46	
165-172	47-67	
165-172	68-88	
165-172	89-109	
165-172	110-130	
165-172	131-151	
165-172	152-172	
165-172	173	

Channel 18	Channel 19	Pattern
173-180	5-25	
173-180	26-46	
173-180	47-67	
173-180	68-88	
173-180	89-109	
173-180	110-130	
173-180	131-151	
173-180	152-172	
173-180	173	

Channel 18	Channel 19	Pattern
181-188	5-28	
181-188	29-52	
181-188	53-76	
181-188	77-100	
181-188	101-124	
181-188	125-148	
181-188	149-172	
181-188	173	

Channel 18	Channel 19	Pattern
189-196	5-23	
189-196	24-42	
189-196	43-61	
189-196	62-80	
189-196	81-99	
189-196	100-118	
189-196	119-137	
189-196	138-156	
189-196	157-175	
189-196	176	

Channel 18	Channel 19	Pattern
197-204	5-14	
197-204	15-24	
197-204	25-34	
197-204	35-44	
197-204	45-54	
197-204	55-64	
197-204	65-74	
197-204	75-84	
197-204	85-94	
197-204	95-104	
197-204	105-114	
197-204	115-124	
197-204	125-134	
197-204	135-144	
197-204	145-154	
197-204	155-164	
197-204	165-174	
197-204	175	

Channel 18	Channel 19	Pattern
205-212	5-25	
205-212	26-46	
205-212	47-67	
205-212	68-88	
205-212	89-109	
205-212	110-130	
205-212	131-151	
205-212	152-172	
205-212	173	

Channel 18	Channel 19	Pattern
213-220	5-21	
213-220	22-38	
213-220	39-55	
213-220	56-72	
213-220	73-89	
213-220	90-106	
213-220	107-123	
213-220	124-140	
213-220	141-157	
213-220	158-174	
213-220	175	

Channel 18	Channel 19	Pattern
221-228	5-11	
221-228	12-18	
221-228	19-25	
221-228	26-32	
221-228	33-39	
221-228	40-46	
221-228	47-53	
221-228	54-60	
221-228	61-67	
221-228	68-74	
221-228	75-81	
221-228	82-88	
221-228	89-95	
221-228	96-102	
221-228	103-109	
221-228	110-116	
221-228	117-123	
221-228	124-130	

Channel 18	Channel 19	Pattern
221-228	131-137	
221-228	138-144	
221-228	145-151	
221-228	152-158	
221-228	159-165	
221-228	166-172	
221-228	173-179	
221-228	180	

Channel 18	Channel 19	Pattern
229-236	5-23	
229-236	24-42	
229-236	43-61	
229-236	62-80	
229-236	81-99	
229-236	100-118	
229-236	119-137	
229-236	138-156	
229-236	157-175	
229-236	176	

Channel 18	Channel 19	Pattern
237-244	5-17	
237-244	18-30	
237-244	31-43	
237-244	44-56	
237-244	57-69	
237-244	70-82	
237-244	83-95	
237-244	96-108	
237-244	109-121	
237-244	122-134	
237-244	135-147	
237-244	148-160	
237-244	161-173	
237-244	174	

Channel 18	Channel 19	Pattern
245-252	5-23	
245-252	24-42	
245-252	43-61	
245-252	62-80	
245-252	81-99	
245-252	100-118	
245-252	119-137	
245-252	138-156	
245-252	157-175	
245-252	176	

Channel 18	Channel 19	Pattern
253	5-23	
253	24-42	
253	43-61	
253	62-80	
253	81-99	
253	100-118	
253	119-137	
253	138-156	
253	157-175	
253	176	

Showline

Dallas

10911 Petal Street
Dalls, TX 75238
Tel: +1 214-647-7880
Fax: +1214-647-8031

Asia

Unit C, 14/F, Roxy Industrial Centre
No. 41-49 Kwai Cheong Road
Kwai Chung, N.T., Hong Kong
Tel: +852 2796 9786
Fax: +852 2798 6545

Auckland

19-21 Kawana Street
Northcote, Auckland 0627
New Zealand
Tel: +64 9 481 0100
Fax: +64 9 481 0101

Europe

Rondweg zuid 85
Winterswijk 7012 JD
The Netherlands
Tel: +31 (0) 543-542516