



20**19**

The New **Original**

The New Original

Give people the tools, and they will build incredible stuff.

That is what it is about, and what it has always been about. We started this journey way back in 1982, creating the worlds first modular aluminium trussing system. That invention, and everything that has followed, has been driven by recognising the needs and demands of a fledgling industry that has since become a global phenomenon – the live events. For us, this means facilitating the build and rebuild of literally thousands of structures every year, and the according stories of excitement, emotion and joy that are so fundamentally human. So for us that defines it, the need to innovate, to enable and ultimately to continue working towards our end goal: to help you build incredible stuff.

Some history. And the future.

Our founding shareholders all share a connection, back in the early days of the phenomenon that is aluminium trussing. Pioneers and visionaries, together responsible for countless innovations that have framed the landscape of todays marketplace. A casual discussion in Leeds, UK, brought together a few of those bright minds, separated by the passing of time. They started with a simple question – how would we do this better? Cappuccino's were consumed, and some thoughts were sparked, with the kind of spark that is hard to extinguish. A simple conclusion; what was missing, was passion, and simplicity of purpose that comes with that. Oh, and the right team, a combination of all the experience and lessons learned, with young, dynamic people to drive the future forward. And so the formula for SIXTY82 was discovered...

Bringing together over 100 years of entertainment industry leadership of our shareholders, the company is a British, Dutch and French alliance designed specifically to bring a fresh view in to the market. Headquartered in Drachten, Netherlands, SIXTY82 has every component required to change the way that lightweight structural systems are used. All over again.



Simplicity. By definition, in purchase, in use and in support.

By Definition. In order to do great work, tools need to be a facilitator, not a distraction. They need to work intuitively, be easy to understand yet far reaching in their capability. We call this wide platform modular engineering; behind that we have the strongest technical team in the industry. Their aim is to rationalise products by improving them; reducing inventory, save time and diminish the carbon footprint.

In Purchase. This means that we will have a razor sharp catalogue that is capable of supporting every build: nothing else. In turn, the experience and knowledge of our dedicated SIXTY82 sales centres will work to ensure rapid availability of every component. We fully understand that non delivery could mean no show.

In Use. With form following function and a restless drive to reduce waste, excess and complexity, our products will be better to work with. From our improved load performance and high production accuracy to the world-first RFID integration. We are producing products that are both easier and more reliable in use. This leaves room for imagination and creativity and ensures that your end result will be better than ever before.

In Support. We have learnt over the years that our products can only perform with the right level of support. To that end, we have the strongest technical team in the industry, who are here for you if you need any help, from the start of the project to the very end. They are inspired by working every day to ensure that our partners push the boundaries to do incredible things.

Technical Innovation

Technical innovation is at the heart of what we do. This year, we are delighted to launch with a number of world firsts in the trussing and staging industry. Our commitment is to support our technical team deliver innovations and new product launches every season – all designed into a modular roadmap to allow you to efficiently scale your investment – and build incredible things.

RFID Ready

Together with our partners we have combined multiple new technologies into a borderless product management platform. Our RFID system will allow seamless tracking of products, both physically and in terms of technical and origination data. This will give you the confidence that you are using the right products in the right way, every single time.

TÜV Approved

SIXTY82 is employing some leading figures in the field of temporary demountable structures. These people have been involved since the beginning of this century in developing standards in Europe. Accordingly, all of our products are calculated, independently approved and assessed to the latest standards. Furthermore, as the technical pioneer of many industry leading technologies, SIXTY82 designs its products with integration in mind. This means that technically challenging constructions can be achieved with the same simplicity and peace of mind as the use of individual products.



Clear technical information, available anywhere

With the SIXTY82 app, and our roadmap for RFID integration, we will provide a single support platform which will guide you through the use of our products. This means that you can easily retrieve load, construction and compliance information wherever you are, in a simple and intuitive way. The platform will continuously be updated with new innovated functionalities such as our SIXTYView and the 3D visualiser, as we develop new technologies driven by our users.

Platform Simplicity

Our promise. Every product will provide solid, reliable service with a simplicity of application. You will get great advice and find a clearer and more focused product range. This means that you will need less different parts in order to achieve more; saving time, space and costs.

AR The **hidden** world behind the page?



Product Personality

In this environment, it is vital that you know both the origin and the capabilities of every product that you work with. However, product specifications, traceability and user data have long been a cumbersome for companies and individuals working in this industry. Until now. We believe that simple, accurate information is a cornerstone of safe building. Accordingly we are proud to launch a suite of tools which centralise data and facilitate easy reference, either physically or digitally, at all times. Our Product Personality system, gives a unique identification to every product and links data about its specific manufacturing process, and TUV certifications. This is unified by an online database of component information and user manuals, and tied to each individual SIXTYTag. Meaning you have multiple ways to get all of the up to date information of the product and its use, anywhere and any time.

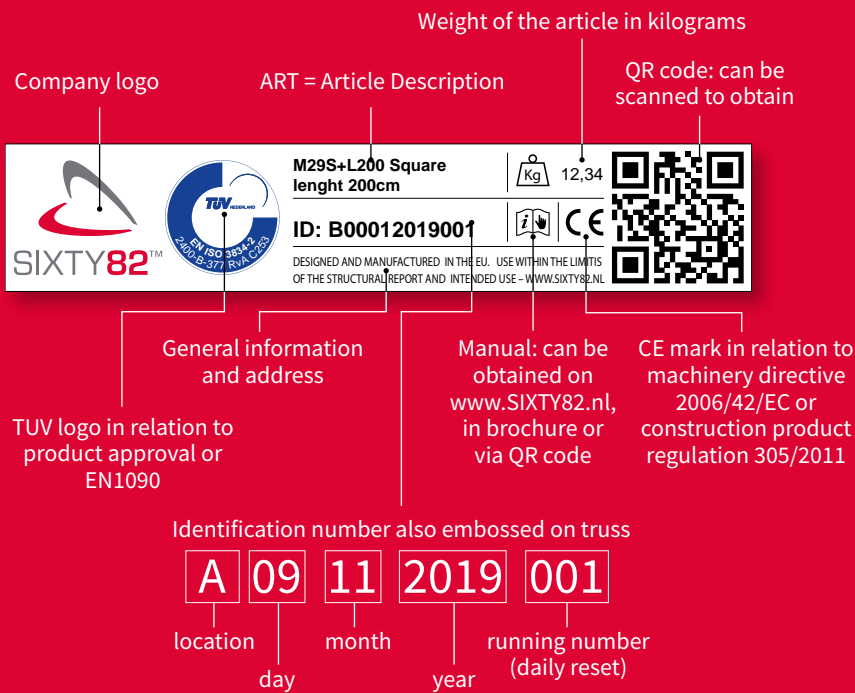

SIXTYTag

The functionality of our Product Personality system is further enhanced with the SIXTYTag – which is standard on every section of trussing that we produce. This unique development of RFID technology combines a special tag with specific extrusion and mounting design. As a result it is optimised to maximise reading accuracy. It is used

within SIXTY82 for the management of stock and designed to facilitate open integration with other systems, enabling the growth of digital asset tracking. We have a roadmap for the development of this unique technology with enhanced functionalities such as EN inspection management and global stock with real-time availability.

SIXTYApp



The SIXTYApp is the first database enabled App platform within the trussing and staging industry. It allows instant access to Product Personalities. Meaning that simply scanning the QR code immediately gives both unique and general data about the origin and safe use of the system.

In addition to this, the App has full 3D augmented reality functionality which is aimed at making it simpler to understand the sometimes complex structural forms of trussing systems. If you scan our AR enabled products or constructions with the App, a 3D render will instantly pop up. They can be easily manipulated to engage users and facilitate quick and simple technical discussions. In the future we will use this technology as the foundation of our intelligent online education system, making it easier for you to learn about the safe and creative use of our systems.





Content

 M series	M29	9
 M series	M39	23
 L series	L35	37
 L series	L52	43
 XL series	XL101	49
	Towers	55
	Roof Systems	63
	LED Screen Supports	71
	Dollies and Extras	75
	Stage Modules	87
	Data Center	100













48.3 x 3 mm

M29



Length

 Ladder	10
 Triangle	12
 Square	13

Corners

 Ladder	14
 Triangle	16
 Square	18

Circle

 Ladder	20
 Triangle	20
 Square	20

Accessories

21

S M L XL



 3.0 Kg/m

 (RFID)
READY

 M

 P.100

 ALU/BLACK

Ladder - M29L

Code	Length
121001	21 cm
121002	25 cm
121003	50 cm
121004	71 cm
121005	100 cm
121007	200 cm
121009	300 cm
121011	400 cm

! Load table single span, supported sideways every 1 meter at top chord M29L

Span m	CPL kg	Deflection mm	2 x load kg	Deflection mm	3 x load kg	Deflection mm	4 x load kg	Deflection mm	UDL kg/m	Deflection mm
2.0	976.5	4	488.3	5	325.5	4	244.1	5	488.3	5
3.0	779.0	8	486.9	10	324.6	10	243.5	10	324.6	10
4.0	625.0	15	422.3	19	323.7	17	242.8	19	242.8	18
5.0	520.9	23	357.8	29	286.7	27	223.8	29	193.7	28
6.0	445.7	33	309.8	42	241.9	39	190.6	42	161.0	41
8.0	343.8	58	243.0	74	183.1	69	146.2	74	96.0	73
10.0	277.6	91	198.5	116	146.2	108	117.6	116	60.9	114
11.0	252.3	110	181.3	140	132.3	131	106.8	140	50.0	137
12.0	230.7	131	166.5	167	120.5	155	97.5	167	41.7	164

! Load table single span, supported sideways every 2 meter at top chord M29L

Span m	CPL kg	Deflection mm	2 x load kg	Deflection mm	3 x load kg	Deflection mm	4 x load kg	Deflection mm	UDL kg/m	Deflection mm
2.0	389.0	1	291.8	1	194.5	1	162.1	1	389.0	1
3.0	257.1	2	192.8	3	128.5	2	107.1	3	171.4	2
4.0	190.5	4	142.8	5	95.2	4	79.4	5	95.2	4
5.0	149.9	6	112.4	7	75.0	7	62.5	7	60.0	7
6.0	122.5	8	91.9	10	61.2	9	51.0	10	40.8	10
8.0	87.1	14	65.3	18	43.6	17	36.3	18	21.8	18
10.0	64.8	22	48.6	28	32.4	26	27.0	28	13.0	28
11.0	56.4	27	42.3	34	28.2	32	23.5	34	10.2	33
12.0	49.1	32	36.8	41	24.5	38	20.5	41	8.2	40

Load table free span M29L

Span m	CPL kg	Deflection mm	2 x load kg	Deflection mm	3 x load kg	Deflection mm	4 x load kg	Deflection mm	UDL kg/m	Deflection mm
1.0	979.2	1	489.6	1	326.4	1	244.8	1	979.2	1
2.0	389.0	1	291.8	1	194.5	1	162.1	1	389.0	1
3.0	234.0	2	176.0	2	117.0	2	98.0	2	156.0	2
4.0	146.0	3	110.0	3	73.0	3	61.0	3	73.0	3
5.0	90.0	3	68.0	4	45.0	4	38.0	4	36.0	4

Find complete loading tables on SIXTY82.nl

All loading data is based on calculations per EN-1999-1-1 and the following assumptions:





- Static loads only.
- Spans supported or suspended at both ends.
- Triangle trusses solely used apex-up, apex-down.
- 2 chords truss to be placed upright, supported from top chord and loaded from bottom chord.
- Truss spans can be constructed of elements of different length.
- Interaction between bending moment and shear force considered.
- Self-weight of truss is already considered.
- Assembled truss systems need an individual structural calculation. Please contact SIXTY82 or a structural engineer.
- Read the manual before use.
- Higher loading can be allowed depending on the truss configuration.



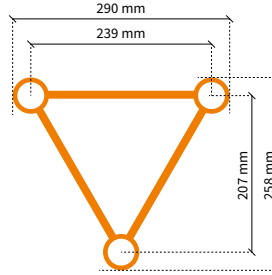

51 x 2 mm



-  4.0 Kg/m
-  M
-  ALU/BLACK
-  ((RFID))
READY
-  P.100

Triangle - M29TX

Code	Length
112001	21 cm
112002	25 cm
112003	29 cm
112004	50 cm
112005	71 cm
112006	100 cm
112007	150 cm
112008	200 cm
112009	250 cm
112010	300 cm
112012	400 cm

Load table M29TX

Span m	CPL kg	Deflection mm	2 x load kg	Deflection mm	3 x load kg	Deflection mm	4 x load kg	Deflection mm	UDL kg/m	Deflection mm
2.0	813.0	3	557.0	4	449.0	4	349.7	4	847.0	4
4.0	444.8	12	317.5	16	234.6	15	188.6	16	248.1	16
6.0	302.2	28	219.5	36	156.6	33	127.5	36	108.4	35
8.0	225.4	50	165.6	64	115.7	59	94.9	64	59.5	62
10.0	176.6	78	130.9	99	90.1	92	74.3	99	36.8	97
12.0	142.3	112	106.4	143	72.3	133	59.9	143	24.5	140
14.0	116.5	152	87.9	194	59.1	181	49.1	194	17.1	190
16.0	96.2	199	73.3	254	48.6	236	40.6	254	12.3	248
20.0	65.4	311	49.8	397	32.9	369	27.7	397	6.6	388

Cantilever load

Span m	1 x Load kg	Deflection mm	UDL kg/m	Deflection mm
0.5	708.0	0	1697.3	0
1.0	406.0	1	706.1	2
1.5	287.6	5	338.2	4
2.0	221.8	11	201.0	8
2.5	179.8	22	132.7	12
3.0	150.5	39	93.7	18
3.5	128.8	62	69.4	25
4.0	112.0	92	53.2	34

Multiple supported span

Span m	CPL kg	Deflection mm	2 x load kg	Deflection mm	UDL kg/m	Deflection mm
2.0	953.3	1	530.5	1	676.9	1
4.0	545.4	6	301.6	5	191.9	5
6.0	379.6	14	210.9	13	90.7	12
8.0	286.5	25	159.6	23	51.9	21
10.0	226.1	39	126.2	36	33.0	33
12.0	183.0	55	102.3	50	22.3	47
14.0	150.3	71	84.1	65	15.8	61
16.0	124.3	88	69.6	80	11.5	75
20.0	84.7	117	47.4	107	6.3	117

 Find complete loading tables on SIXTY82.nl

All loading data is based on calculations per EN-1999-1-1 and the following assumptions:

- Static loads only.
- Spans supported or suspended at both ends.
- Triangle trusses solely used apex-up, apex-down.
- 2 chords truss to be placed upright, supported from top chord and loaded from bottom chord.
- Truss spans can be constructed of elements of different length.

- Interaction between bending moment and shear force considered.
- Self-weight of truss is already considered.
- Assembled truss systems need an individual structural calculation. Please contact SIXTY82 or a structural engineer.
- Read the manual before use.
- Higher loading can be allowed depending on the truss configuration.



48.3 x 3 mm

Length Square

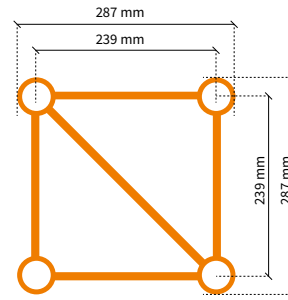
M29S

6.3 Kg/m

 (RFID)
READY

M

P.100

ALU/BLACK

Square - M29S

Code	Length
128001	21 cm
128002	25 cm
128003	29 cm
128004	50 cm
128005	71 cm
128015	75 cm
128006	100 cm
128007	150 cm
128008	200 cm
128009	250 cm
128010	300 cm
128012	400 cm

Load table M29S

Span	CPL	Deflection	2 x load	Deflection	3 x load	Deflection	4 x load	Deflection	UDL	Deflection
m	kg	mm	kg	mm	kg	mm	kg	mm	kg/m	mm
2.0	1952.5	4	976.3	5	650.8	4	488.1	5	976.3	5
4.0	1308.4	15	941.5	19	647.1	17	485.3	19	485.3	18
6.0	921.5	33	649.9	42	492.3	39	392.3	42	321.6	41
8.0	705.9	58	505.5	74	371.2	69	299.1	74	195.7	73
10.0	567.4	91	410.7	116	295.3	108	239.7	116	123.2	114
12.0	470.1	131	343.2	167	243.0	155	198.3	167	83.8	164
14.0	397.3	178	292.3	228	204.3	211	167.5	228	60.1	223
16.0	340.4	233	252.2	297	174.3	276	143.4	297	44.7	291
20.0	256.0	364	192.3	464	130.3	431	107.9	464	26.5	454

Cantilever load

Span	1 x Load	Deflection	UDL	Deflection
m	kg	mm	kg/m	mm
0.5	980.5	0	1958.2	0
1.0	979.1	1	976.3	1
1.5	839.6	5	649.0	3
2.0	652.5	12	485.3	7
2.5	539.5	24	387.1	13
3.0	458.8	43	276.5	19
3.5	398.2	69	204.9	27
4.0	351.0	103	159.9	36

Multiple supported span

Span	CPL	Deflection	2 x Load	Deflection	UDL	Deflection
m	kg	mm	kg	mm	kg/m	mm
2.0	1418.0	1	726.0	1	779.9	0
4.0	1407.7	6	715.4	5	387.1	4
6.0	1109.9	15	625.5	14	256.2	12
8.0	866.3	28	479.4	25	153.7	23
10.0	705.5	45	391.5	40	100.7	37
12.0	589.6	64	327.8	58	70.6	54
14.0	501.4	87	279.2	79	51.8	73
16.0	431.5	112	240.6	101	39.2	94
20.0	326.3	165	182.2	150	23.9	158

Find complete loading tables on SIXTY82.nl

All loading data is based on calculations per EN-1999-1-1 and the following assumptions:

- Static loads only.
- Spans supported or suspended at both ends.
- Triangle trusses solely used apex-up, apex-down.
- 2 chords truss to be placed upright, supported from top chord and loaded from bottom chord.
- Truss spans can be constructed of elements of different length.
- Interaction between bending moment and shear force considered.
- Self-weight of truss is already considered.
- Assembled truss systems need an individual structural calculation. Please contact SIXTY82 or a structural engineer.
- Read the manual before use.
- Higher loading can be allowed depending on the truss configuration.

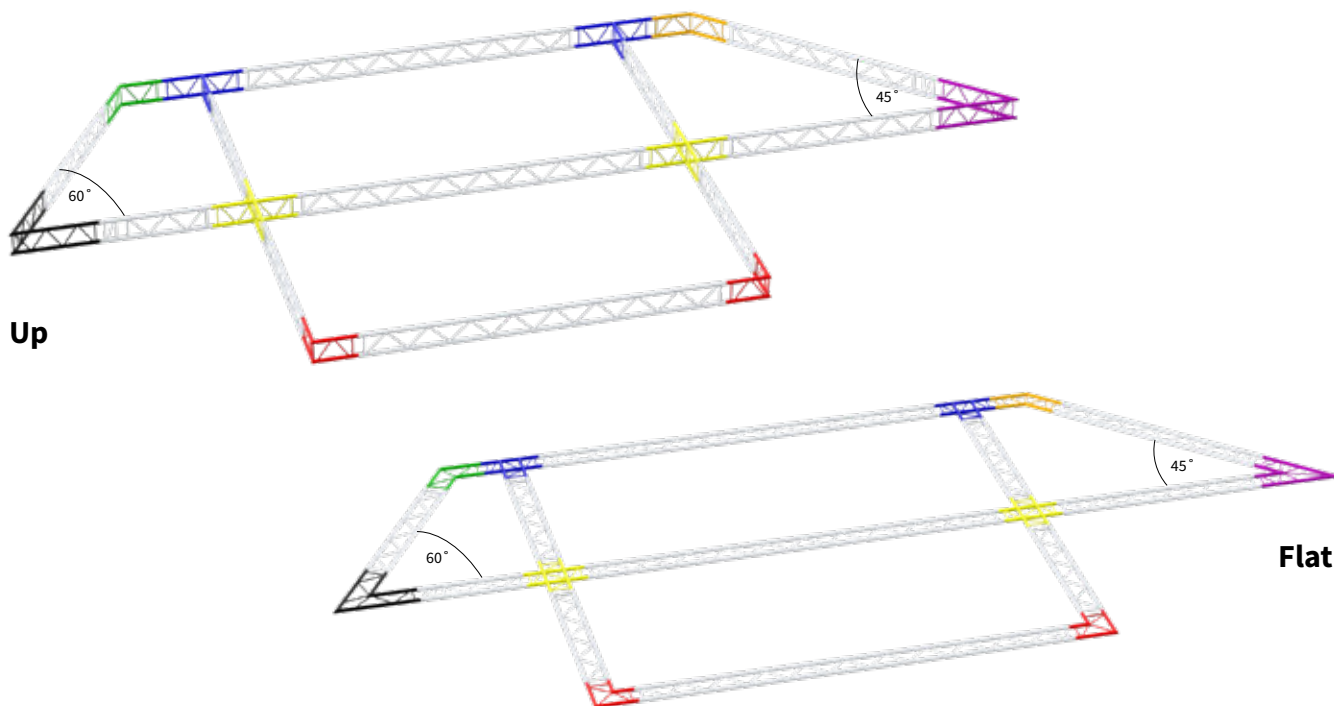

Show S29L in



2way
up

M29L-C201U **45° UP**
122001 5.35 kg

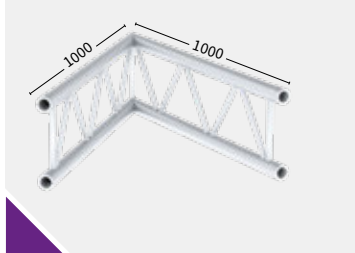

M29L-C202U **60° UP**
122002 5.43 kg

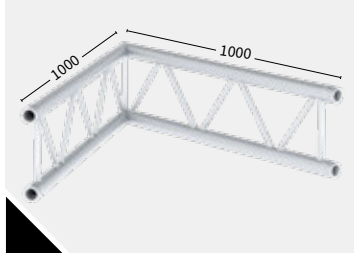

M29L-C203U **90° UP**
122003 2.92 kg



M29L-C204U **120° UP**
122004 2.96 kg



M29L-C205U **135° UP**
122005 2.99 kg



2way
flat

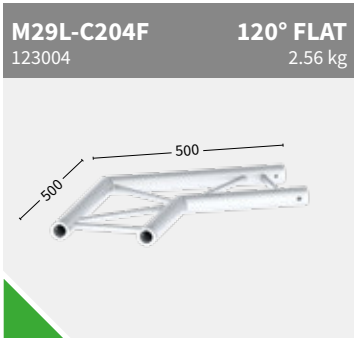

3way



4way

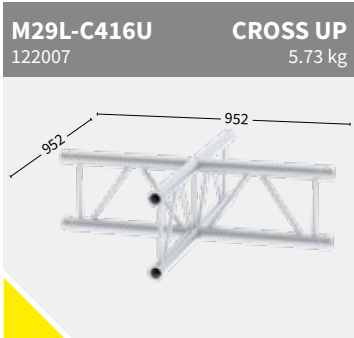

Box

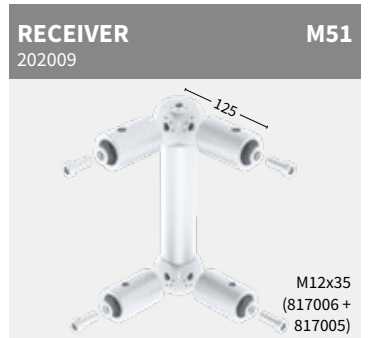
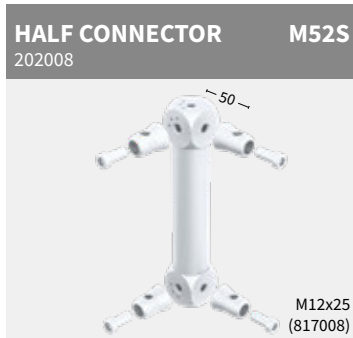

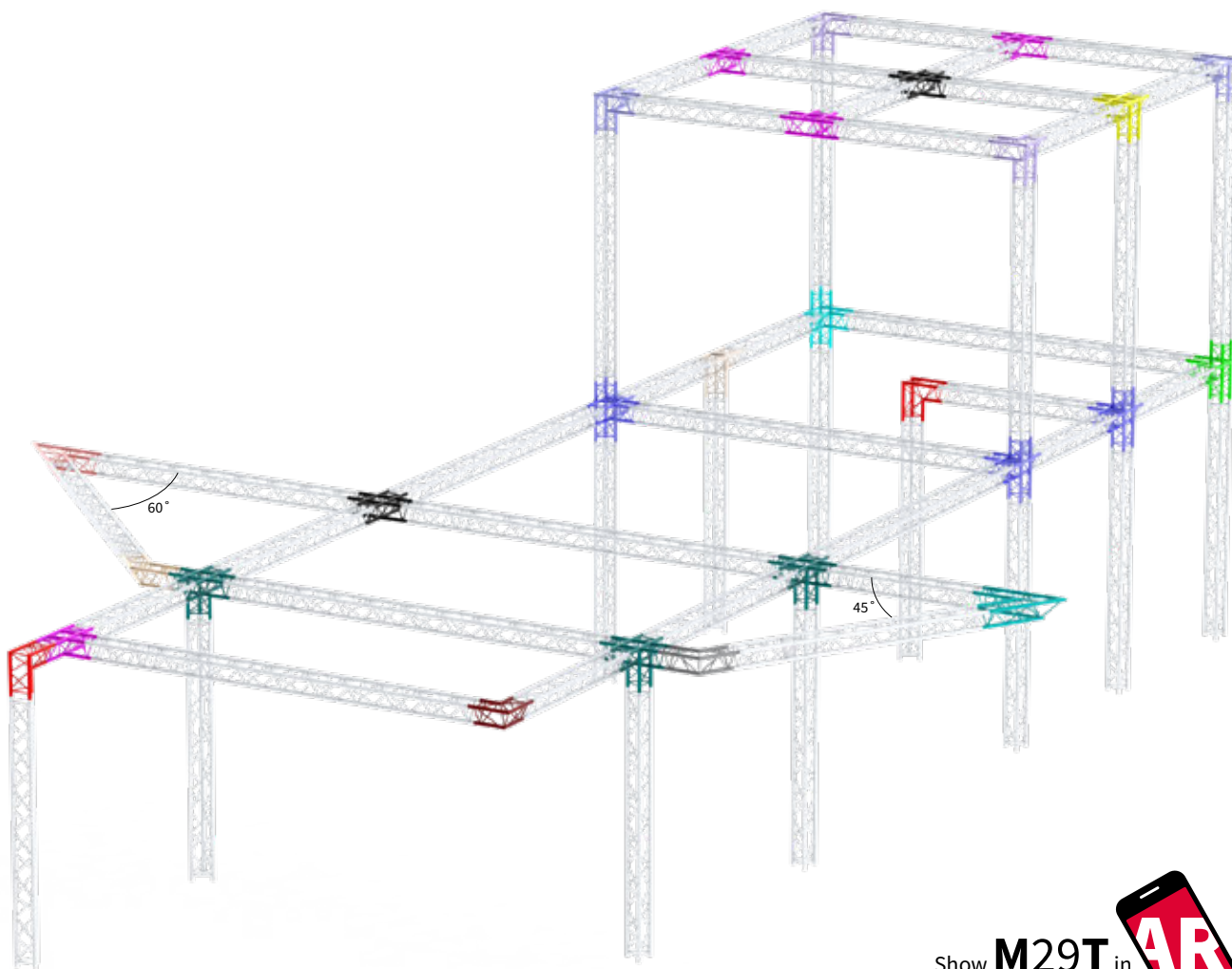

2way

<p>M29T-C201 126001</p> <p>45° 6.43 kg</p>	<p>M29T-C202 126002</p> <p>60° 7.11 kg</p>	<p>M29T-C203 126003</p> <p>90° 3.79 kg</p>
<p>M29T-C204 126004</p> <p>120° 4.32 kg</p>	<p>M29T-C205 126005</p> <p>135° 4.63 kg</p>	<p>M29T-C207 126006</p> <p>90° VERTICAL 4.23 kg</p>

3way

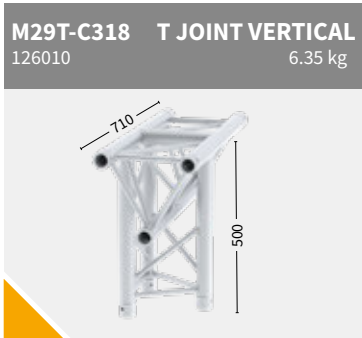
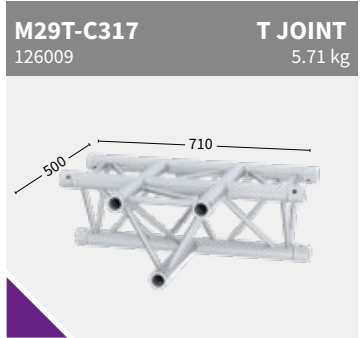
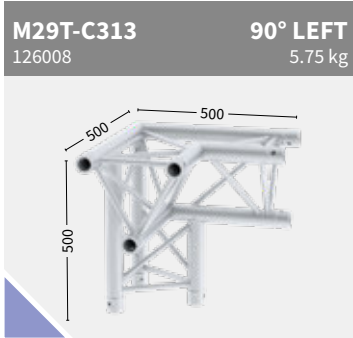
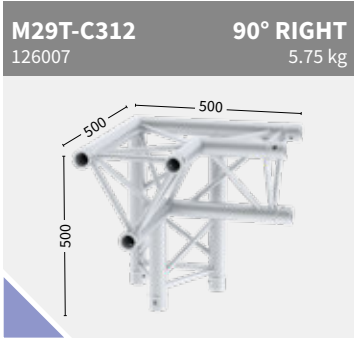

4way

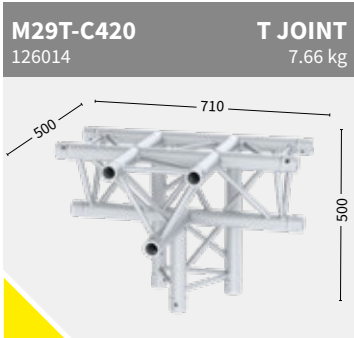
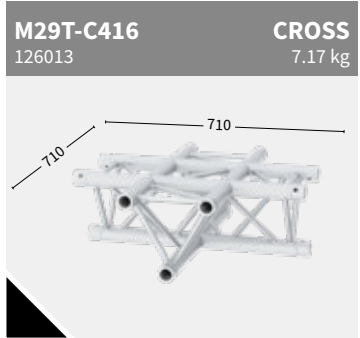
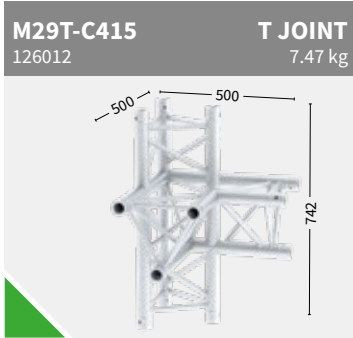
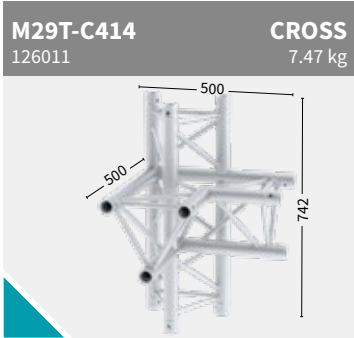

5way

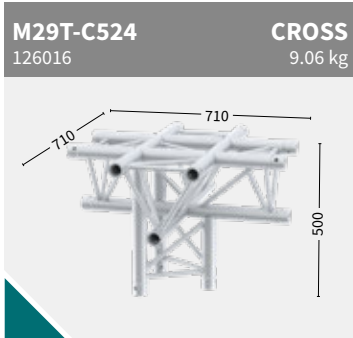
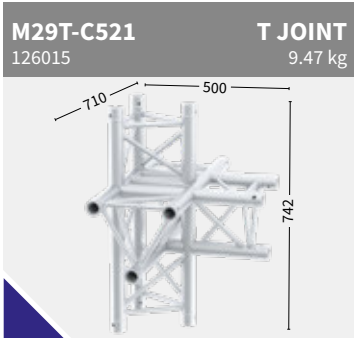

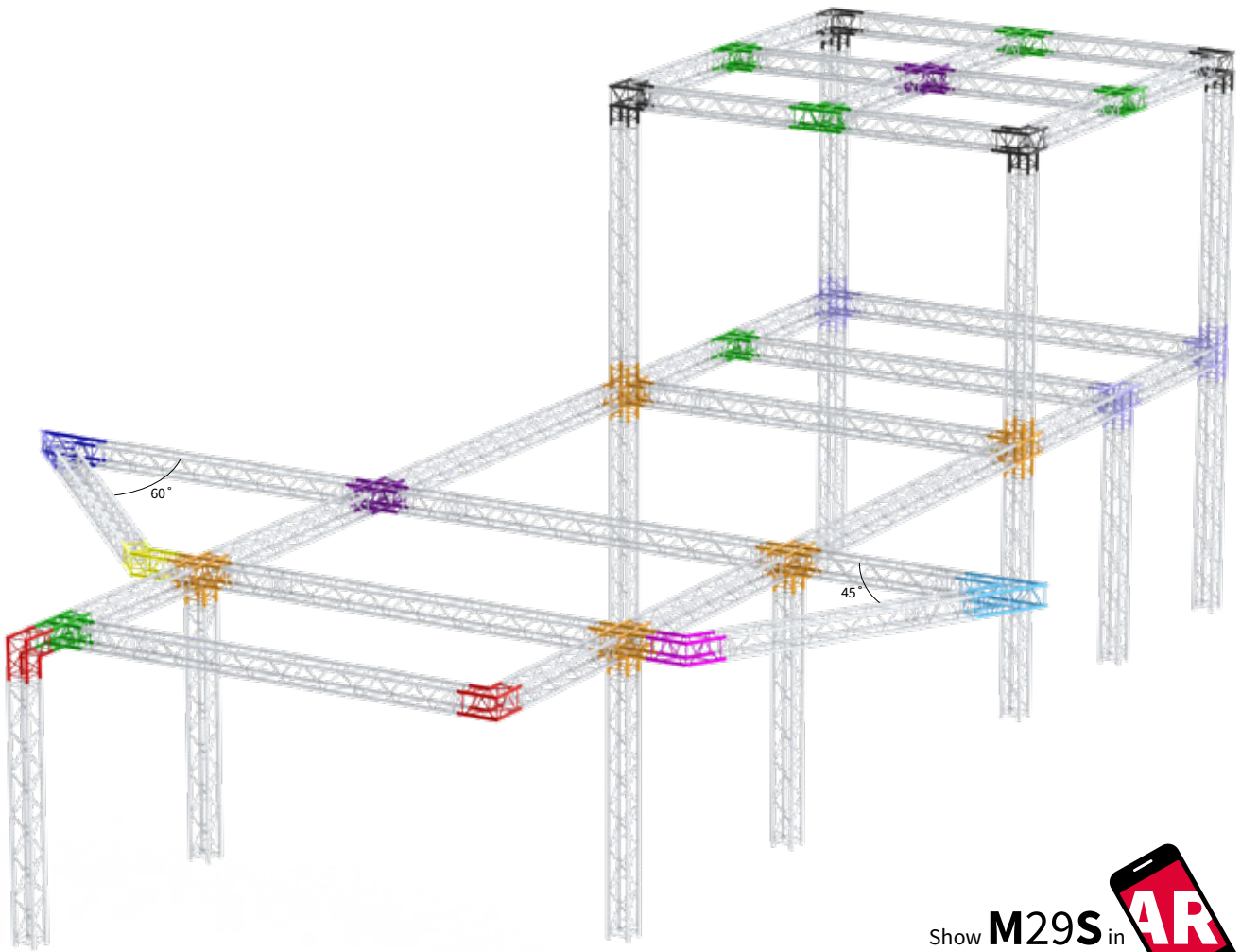

2way

M29S-C201 **45°**
129001 8.72 kg

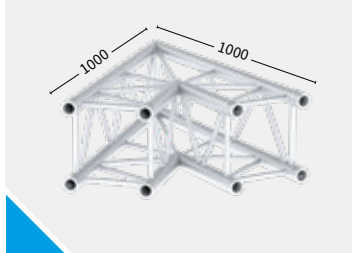

M29S-C202 **60°**
129002 9.61 kg

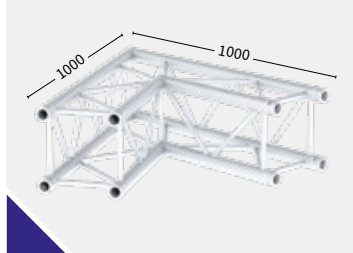

M29S-C203 **90°**
129003 5.13 kg



M29S-C204 **120°**
129004 5.83 kg



M29S-C205 **135°**
129005 6.21 kg



3way

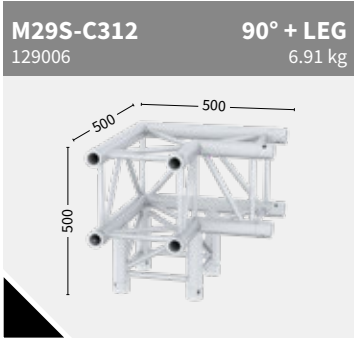

4way

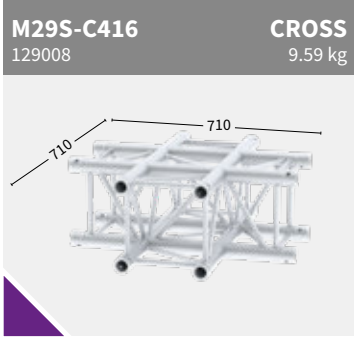

5way



BOX

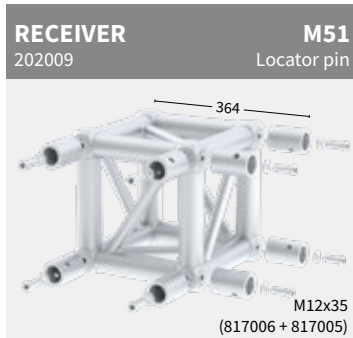
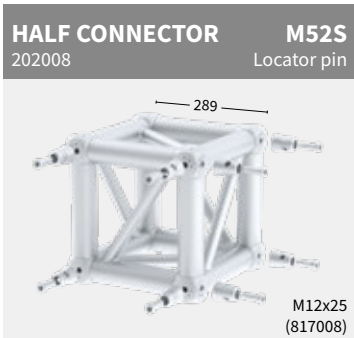



3.0 Kg/m

M

ALU/BLACK

 ((RFID))
READY

P.100

M29L Circle part - up

Code	∅ Diameter	Angle	Parts/Circle
124001	2.00 m	90	4
124002	3.00 m	90	4
124003	4.00 m	90	4
124004	5.00 m	90	4

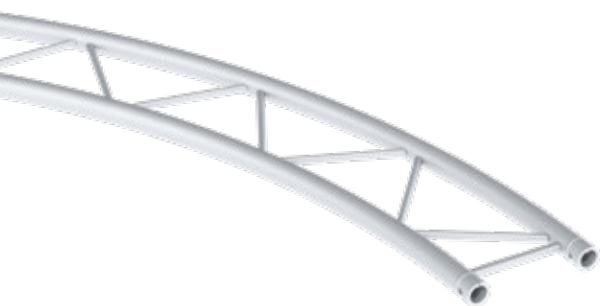

3.0 Kg/m

M

ALU/BLACK

 ((RFID))
READY

P.100

M29L Circle part - flat

Code	∅ Diameter	Angle	Parts/Circle
124005	2.00 m	90	4
124006	3.00 m	90	4
124007	4.00 m	90	4
124008	5.00 m	90	4



5.0 Kg/m

M

ALU/BLACK

 ((RFID))
READY

P.100

M29T Circle part

Code	∅ Diameter	Angle	Parts/Circle
127001	2.00 m	90	4
127002	3.00 m	90	4
127003	4.00 m	90	4
127004	5.00 m	90	4
127005	6.00 m	45	8
127006	8.00 m	45	8
127007	10.00 m	45	8
127008	10.00 m	30	12



6.3 Kg/m

M

ALU/BLACK

 ((RFID))
READY

P.100

M29S Circle part

Code	∅ Diameter	Angle	Parts/Circle
130001	2.00 m	90	4
130002	3.00 m	90	4
130003	4.00 m	90	4
130004	5.00 m	90	4
130005	6.00 m	45	8
130006	8.00 m	45	8
130007	10.00 m	45	8
130008	10.00 m	30	12

• Subject to tolerance, because product is 100% handmade.

Accessories

M29

BASE PLATE
211003 329 x 297 x 5 mm



Half connector (202007) and bolt (817003) not included

BASE PLATE
211004 329 x 329 x 5 mm



Half connector (202007) and bolt (817003) not included

LIFTING BRACKET M29
212001 WLL 1000 kg



HANG-ON82 M29 TO M29S-T
251003 10.2 kg



NEW

HANG-ON82 M29 TO M29L
251004 7.06 kg



NEW

BOOK CORNER M29T-S
198001



NEW

WALL ADAPTER M29S-T
212006



NEW

BOOK-FIX
198004



BASE PLATE STEEL		M29/M39
Code	Finish	35,0 kg
211009	Black	Ø 800 x 8 mm
211010	Zinc	



Half connector not included

BASE PLATE STEEL		M29/M39
Code	Finish	41,0 kg
211011	Black	800 x 800 x 8 mm
211012	Zinc	



Half connector not included







48.3 x 3 mm

M39

Length

 Triangle	24
 Square	25
 Rectangle	26

Corners

 Triangle	28
 Square	30

Circle

 Triangle	32
 Square	32

Accessories



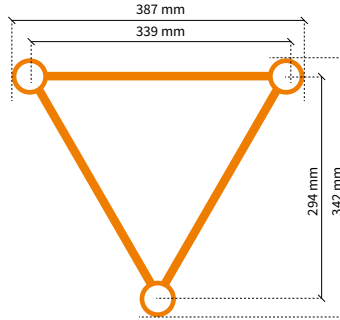

33

S M L XL



Triangle - M39T

Code	Length
135002	25 cm
135004	50 cm
135005	81 cm
135006	100 cm
135008	200 cm
135010	300 cm
135012	400 cm

-  5.5 Kg/m
-  (RFID) READY
-  M
-  P.100
-  ALU/BLACK

Load table M39T

Span m	CPL kg	Deflection mm	2 x load kg	Deflection mm	3 x load kg	Deflection mm	4 x load kg	Deflection mm	UDL kg/m	Deflection mm
2.0	1446.7	2	1013.7	3	725.9	3	544.4	3	1088.8	3
4.0	830.6	9	578.5	11	449.9	11	355.1	11	490.9	11
6.0	577.7	20	411.7	26	305.2	24	245.1	26	215.7	25
8.0	438.6	36	316.9	46	228.6	42	185.3	46	119.3	45
10.0	349.6	56	255.2	71	180.6	66	147.4	71	74.8	70
12.0	287.1	80	211.4	102	147.5	95	121.0	102	50.5	100
14.0	240.4	109	178.4	139	122.9	129	101.2	139	35.9	136
16.0	203.7	143	152.3	182	103.8	169	85.8	182	26.5	178
20.0	148.9	223	113.1	284	75.5	264	62.9	284	15.3	278

Cantilever load

Span m	1 x Load kg	Deflection mm	UDL kg/m	Deflection mm
0.5	1092.2	0	2182.2	0
1.0	722.5	1	1088.8	1
1.5	527.3	3	610.0	3
2.0	414.1	8	359.0	5
2.5	340.0	15	241.5	8
3.0	287.6	27	173.2	12
3.5	248.4	43	130.0	17
4.0	217.9	64	100.8	23

Multiple supported span

Span m	CPL kg	Deflection mm	2 x Load kg	Deflection mm	UDL kg/m	Deflection mm
2.0	1582.1	1	811.8	1	870.2	1
4.0	980.4	4	538.5	4	344.6	3
6.0	705.1	10	389.7	9	165.1	8
8.0	545.0	18	302.3	16	97.1	15
10.0	439.2	28	244.2	25	63.2	23
12.0	363.3	39	202.4	36	43.8	33
14.0	305.7	53	170.5	48	31.8	45
16.0	259.9	67	145.1	61	23.7	57
20.0	190.8	96	106.7	88	14.0	93

 Find complete loading tables on SIXTY82.nl

All loading data is based on calculations per EN-1999-1-1 and the following assumptions:

- Static loads only.
- Spans supported or suspended at both ends.
- Triangle trusses solely used apex-up, apex-down.
- 2 chords truss to be placed upright, supported from top chord and loaded from bottom chord.
- Truss spans can be constructed of elements of different length.

- Interaction between bending moment and shear force considered.
- Self-weight of truss is already considered.
- Assembled truss systems need an individual structural calculation. Please contact SIXTY82 or a structural engineer.
- Read the manual before use.
- Higher loading can be allowed depending on the truss configuration.



48.3 x 3 mm

Length Square

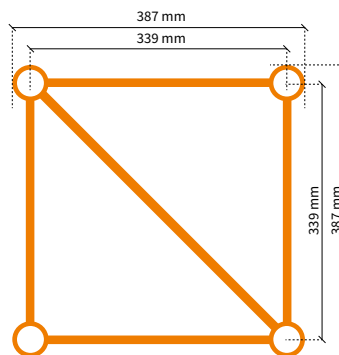
M39S

Square - M39S

Code	Length
138001	21 cm
138002	25 cm
138004	50 cm
138005	81 cm
138006	100 cm
138008	200 cm
138010	300 cm
138012	400 cm

6.9 Kg/m



M



P.100



ALU/BLACK

Load table M39S

Span	CPL	Deflection	2 x load	Deflection	3 x load	Deflection	4 x load	Deflection	UDL	Deflection
m	kg	mm	kg	mm	kg	mm	kg	mm	kg/m	mm
2.0	2512.6	3	1256.3	3	837.5	3	628.1	3	1256.3	3
4.0	1726.7	10	1227.7	13	833.4	12	625.0	13	625.0	13
6.0	1244.2	23	858.9	30	681.0	28	534.7	30	414.6	29
8.0	967.3	41	680.2	53	518.5	49	412.2	53	279.4	52
10.0	786.3	65	560.1	83	415.9	77	333.7	83	176.6	81
12.0	658.1	93	473.4	119	344.8	110	278.6	119	120.7	116
14.0	561.7	127	407.5	162	292.3	150	237.4	162	87.0	158
16.0	486.3	166	355.3	211	251.6	196	205.3	211	65.2	207
20.0	374.3	259	277.2	330	192.2	307	157.9	330	39.5	323

Cantilever load

Span	1 x Load	Deflection	UDL	Deflection
m	kg	mm	kg/m	mm
0.5	1260.9	0	2518.8	0
1.0	1259.4	1	1256.3	1
1.5	1107.4	3	835.4	2
2.0	861.1	8	625.0	4
2.5	721.3	16	498.8	8
3.0	619.5	29	365.4	13
3.5	541.9	47	270.9	18
4.0	480.8	71	212.0	24

Multiple supported span

Span	CPL	Deflection	2 x Load	Deflection	UDL	Deflection
m	kg	mm	kg	mm	kg/m	mm
2.0	1825.1	0	935.5	0	1003.8	0
4.0	1813.8	4	923.8	3	498.8	2
6.0	1477.6	10	825.5	9	330.5	8
8.0	1154.3	19	635.7	17	204.7	15
10.0	954.6	30	527.5	27	134.0	25
12.0	808.2	44	447.7	40	95.5	36
14.0	695.7	60	386.1	55	70.9	50
16.0	606.0	79	336.8	71	54.4	66
20.0	470.3	119	262.0	108	34.1	112

Find complete loading tables on SIXTY82.nl



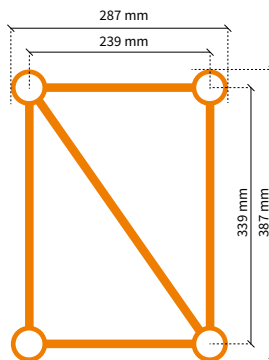

All loading data is based on calculations per EN-1999-1-1 and the following assumptions:

- Static loads only.
- Spans supported or suspended at both ends.
- Triangle trusses solely used apex-up, apex-down.
- 2 chords truss to be placed upright, supported from top chord and loaded from bottom chord.
- Truss spans can be constructed of elements of different length.
- Interaction between bending moment and shear force considered.
- Self-weight of truss is already considered.
- Assembled truss systems need an individual structural calculation. Please contact SIXTY82 or a structural engineer.
- Read the manual before use.
- Higher loading can be allowed depending on the truss configuration.



Rectangle - M39R

Code	Length
141001	21 cm
141001	25 cm
141004	50 cm
141005	81 cm
141006	100 cm
141008	200 cm
141010	300 cm
141012	400 cm

-  6.9 Kg/m
-  ((RFID) READY)
-  M
-  P.100
-  ALU/BLACK

Load table M39R

Span m	CPL kg	Deflection mm	2 x load kg	Deflection mm	3 x load kg	Deflection mm	4 x load kg	Deflection mm	UDL kg/m	Deflection mm
2.0	2512.6	3	1256.3	3	837.5	3	628.1	3	1256.3	3
4.0	1726.7	10	1227.7	13	833.4	12	625.0	13	625.0	13
6.0	1244.2	23	858.9	30	681.0	28	534.7	30	414.6	29
8.0	967.3	41	680.2	53	518.5	49	412.2	53	279.4	52
10.0	786.3	65	560.1	83	415.9	77	333.7	83	176.6	81
12.0	658.1	93	473.4	119	344.8	110	278.6	119	120.7	116
14.0	561.7	127	407.5	162	292.3	150	237.4	162	87.0	158
16.0	486.3	166	355.3	211	251.6	196	205.3	211	65.2	207
20.0	374.3	259	277.2	330	192.2	307	157.9	330	39.5	323

Cantilever load

Span m	1 x Load kg	Deflection mm	UDL kg/m	Deflection mm
0.5	1260.9	0	2518.8	0
1.0	1259.4	1	1256.3	1
1.5	1107.4	3	835.4	2
2.0	861.1	8	625.0	4
2.5	721.3	16	498.8	8
3.0	619.5	29	365.4	13
3.5	541.9	47	270.9	18
4.0	480.8	71	212.0	24

Multiple supported span

Span m	CPL kg	Deflection mm	2 x Load kg	Deflection mm	UDL kg/m	Deflection mm
2.0	1825.1	0	935.5	0	1003.8	0
4.0	1813.8	4	923.8	3	498.8	2
6.0	1477.6	10	825.5	9	330.5	8
8.0	1154.3	19	635.7	17	204.7	15
10.0	954.6	30	527.5	27	134.0	25
12.0	808.2	44	447.7	40	95.5	36
14.0	695.7	60	386.1	55	70.9	50
16.0	606.0	79	336.8	71	54.4	66
20.0	470.3	119	262.0	108	34.1	112

 Find complete loading tables on SIXTY82.nl

All loading data is based on calculations per EN-1999-1-1 and the following assumptions:

- Static loads only.
- Spans supported or suspended at both ends.
- Triangle trusses solely used apex-up, apex-down.
- 2 chords truss to be placed upright, supported from top chord and loaded from bottom chord.
- Truss spans can be constructed of elements of different length.

- Interaction between bending moment and shear force considered.
- Self-weight of truss is already considered.
- Assembled truss systems need an individual structural calculation. Please contact SIXTY82 or a structural engineer.
- Read the manual before use.
- Higher loading can be allowed depending on the truss configuration.

HANG-ON82



WHY: HANG-ON82

- Alternative for the T-joint
- Flexible in use: can be used on every point in the grid
- Easy to use and assemble
- Can be used in conjunction with box corners and weld corners (spacers or special truss length needed)
- Can be used for ladder, triangle and square truss
- Natural and black finish available
- Load capacity 900 KG*

PARTS

1	202008	Half connector M52S	M series
2	817008	Bolt M12*25 Low head	M series
3	251008	Hang-on82 Spacer 30 mm (in combination with weld corners)	M series
4	817025	Bolt M12*60 Low head	M series

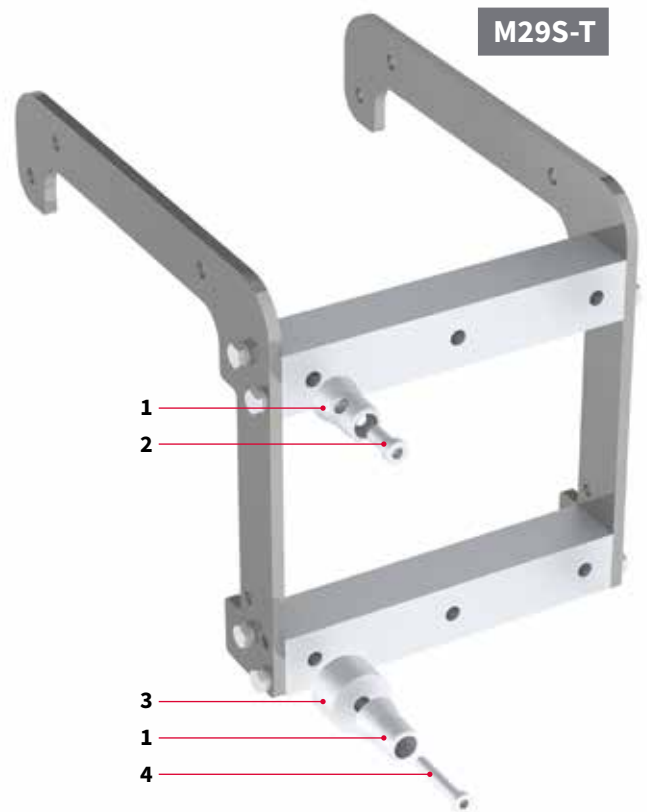

The design of this product is intellectually protected.

* A truss grid in which the HANG-ON82 is used must be checked by an chartered engineer on a case by case basis.

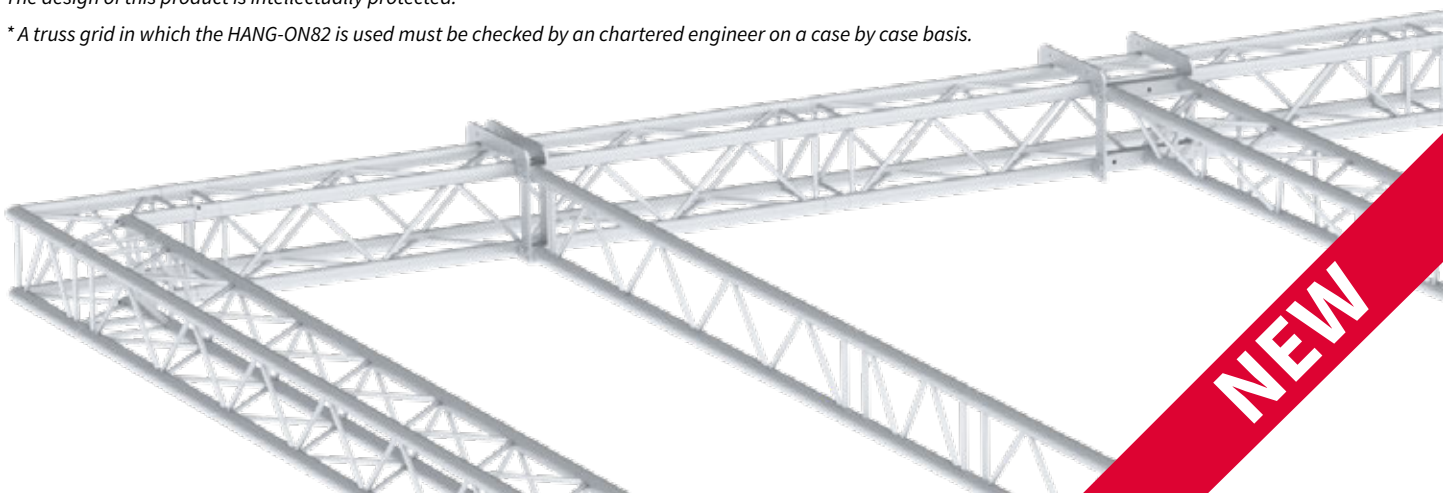

NEW

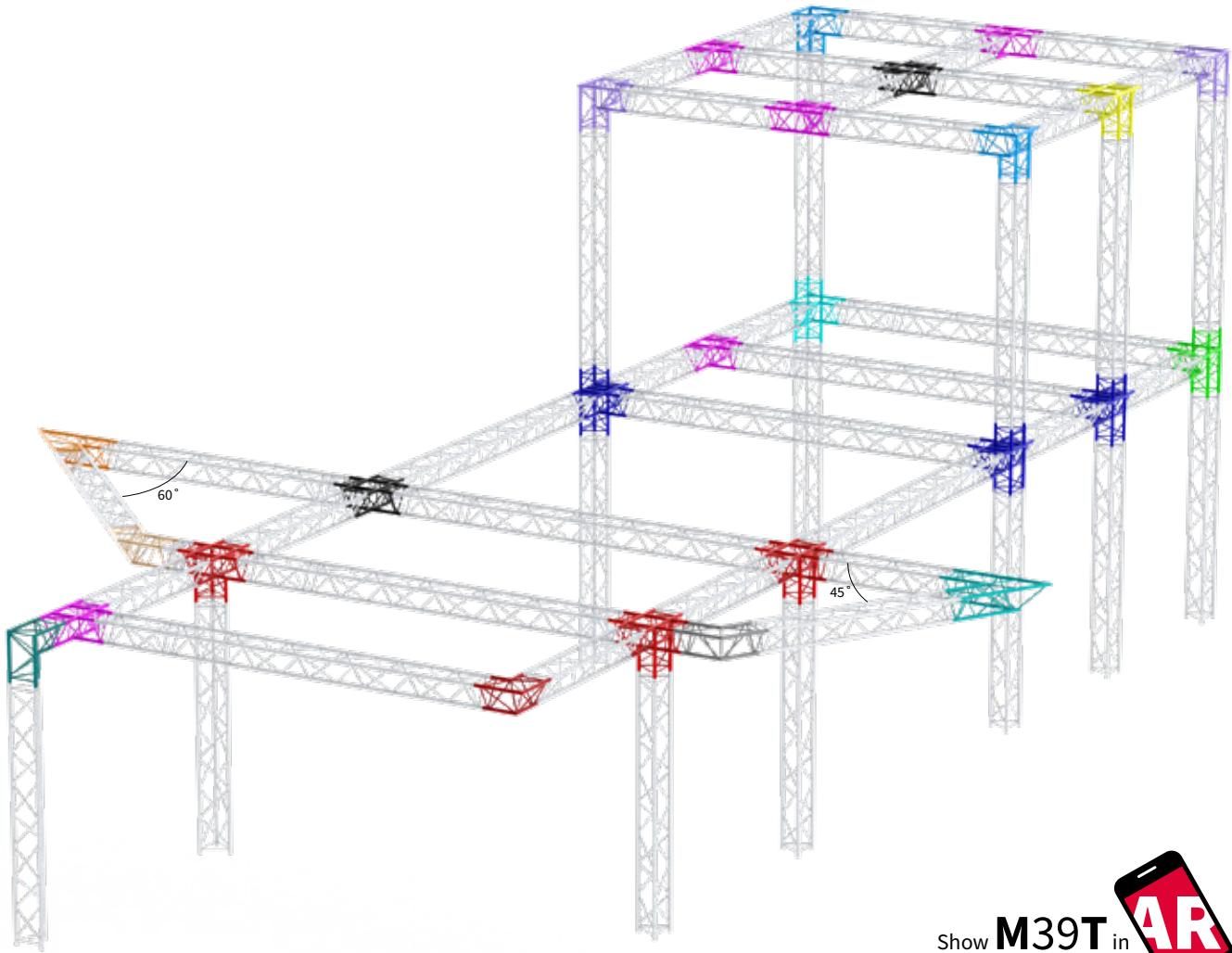

2way

<p>M39T-C201 136001</p> <p>45° 8.04 kg</p>	<p>M39T-C202 136002</p> <p>60° 8.92 kg</p>	<p>M39T-C203 136003</p> <p>90° 4.73 kg</p>
<p>M39T-C204 136004</p> <p>120° 5.53 kg</p>	<p>M39T-C205 136005</p> <p>135° 5.99 kg</p>	<p>M39T-C207 136006</p> <p>90° VERTICAL 5.38 kg</p>

3way

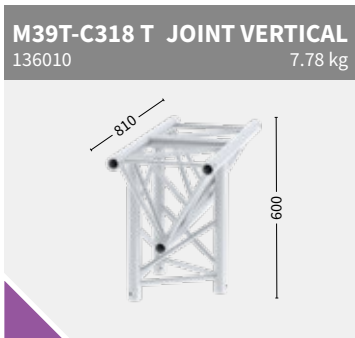
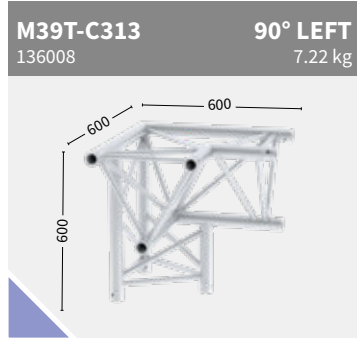
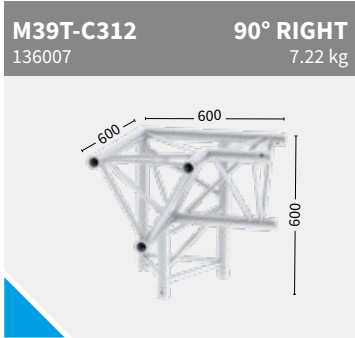

4way

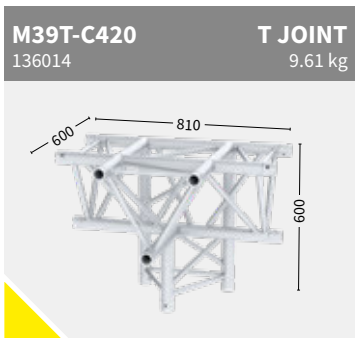
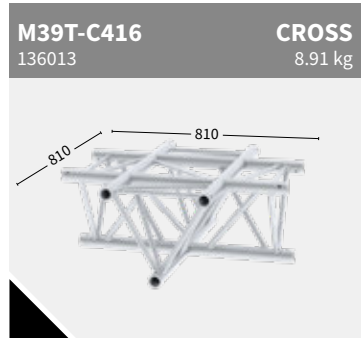
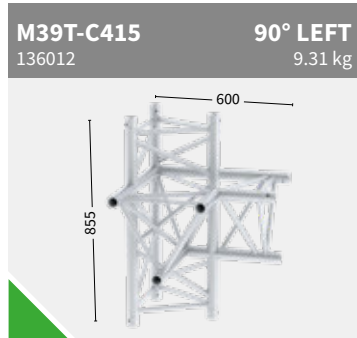
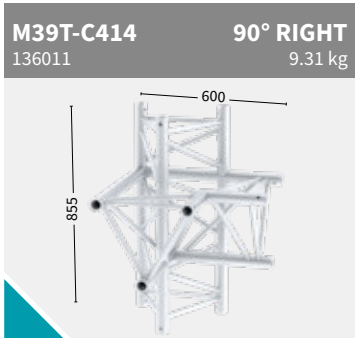

5way

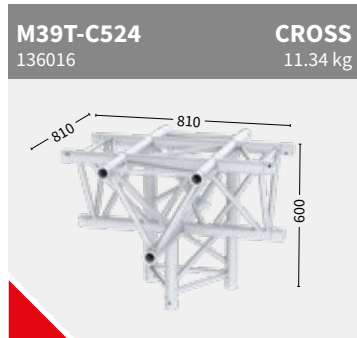
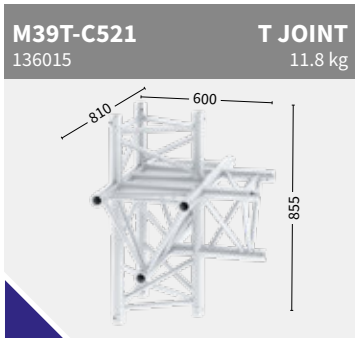

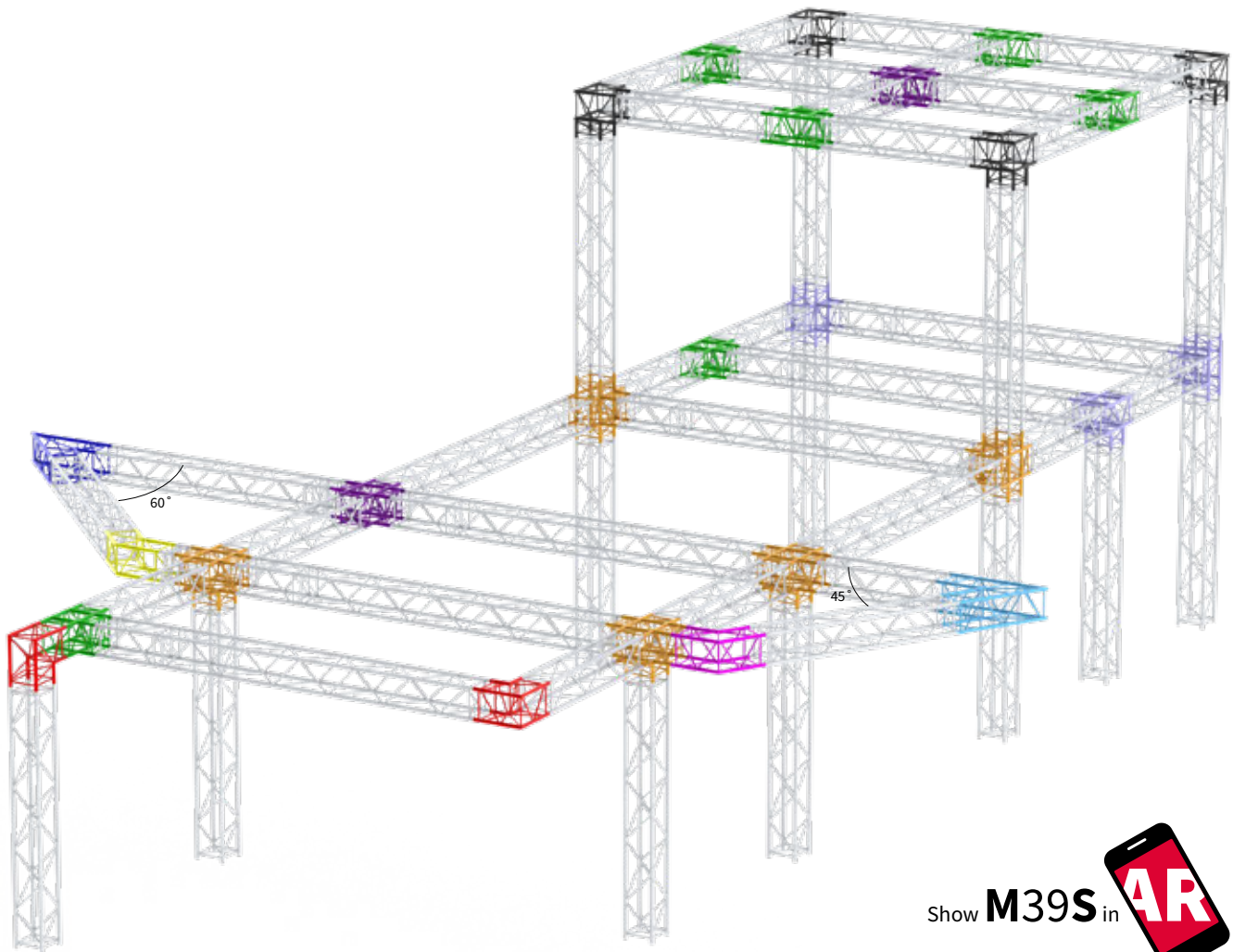

2way

M39S-C201 **45°**
139001 10.23 kg

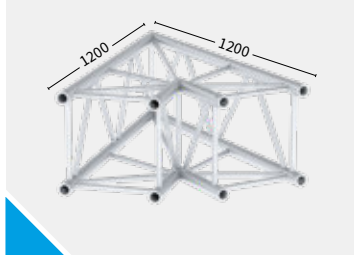

M39S-C202 **60°**
139002 12.02 kg

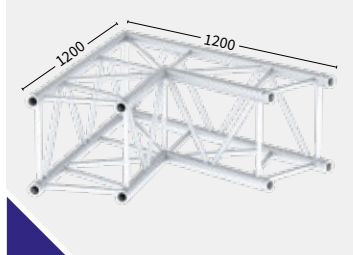

M39S-C203 **90°**
139003 6.51 kg



M39S-C204 **120°**
139004 7.16 kg

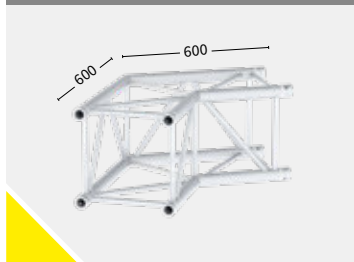

M39S-C205 **135°**
139005 7.5 kg

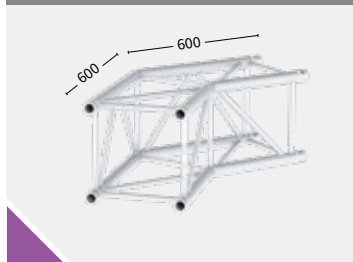

3way

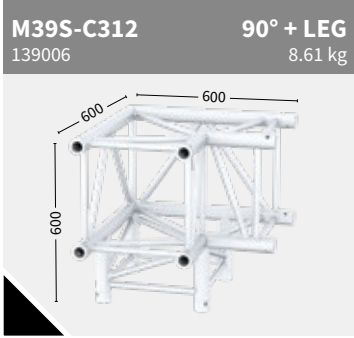

4way



5way



Box

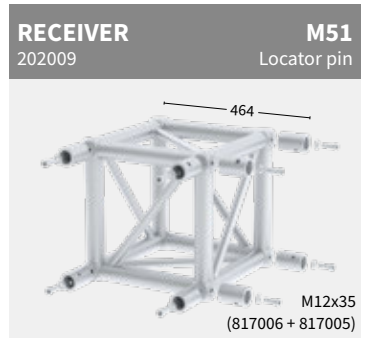
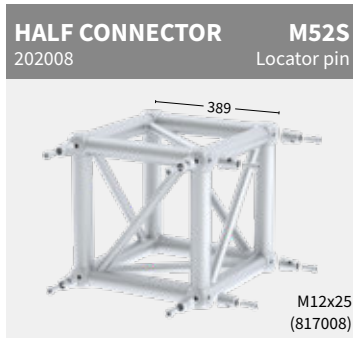

Box

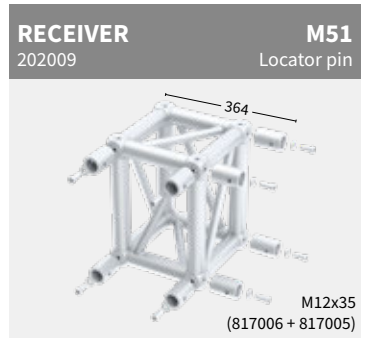
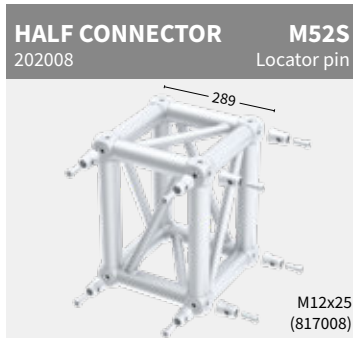

M39

Circles



48.3 x 3 mm



M39T Circle part

Code	∅ Diameter	Angle	Parts/Circle
137001	2.00 m	90	4
137002	3.00 m	90	4
137003	4.00 m	90	4
137004	5.00 m	90	4
137005	6.00 m	45	8
137006	8.00 m	45	8
137007	10.00 m	45	8
137008	10.00 m	30	12

- 6.3 Kg/m
- M
- ALU/BLACK
- ((RFID))
READY
- P.100

M39S Circle part

Code	∅ Diameter	Angle	Parts/Circle
140001	2.00 m	90	4
140002	3.00 m	90	4
140003	4.00 m	90	4
140004	5.00 m	90	4
140005	6.00 m	45	8
140006	8.00 m	45	8
140007	10.00 m	45	8
140008	10.00 m	30	12

- 6.3 Kg/m
- M
- ALU/BLACK
- ((RFID))
READY
- P.100

• Subject to tolerance, because product is 100% handmade.

BOX corner invention evolved

Locator pin design and special mail connector will allow much easier user configuration of box corners.

Higher shear force capacity due to lower eccentricity when using male connectors.

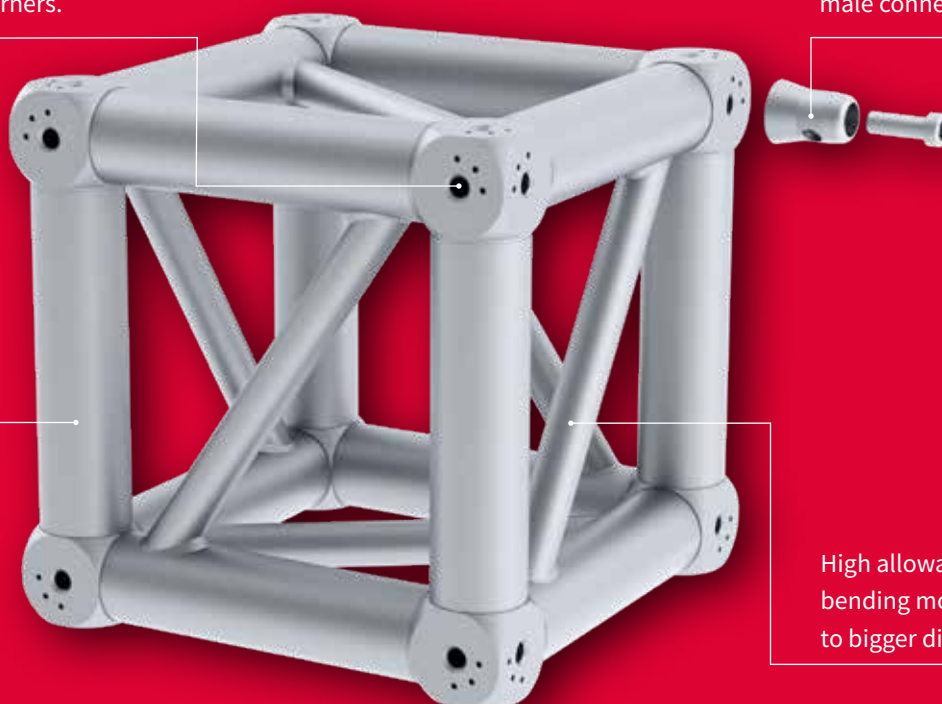

Less components giving increased user simplicity and better value.

High allowable bending moment due to bigger diagonal.

BASE PLATE
211005 429 x 384 x 5 mm

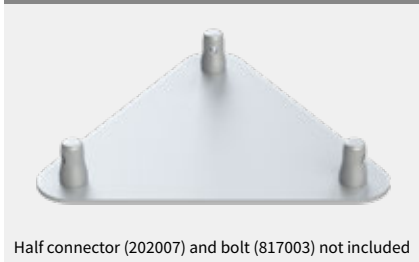

Half connector (202007) and bolt (817003) not included

BASE PLATE
211006 429 x 429 x 5 mm



Half connector (202007) and bolt (817003) not included

LIFTING BRACKET
212002 WLL 1000 kg



HANG-ON82 **M39 TO M9S-T**
251005 11.72 kg



NEW

HANG-ON82 **M39 TO M39S-T**
251006 13.1 kg



NEW

HANG-ON82 **M39 TO M39L**
251007 8.58 kg



NEW

WALL ADAPTER **M39R**
212006



NEW

BOOK CORNER **M39T-S**
198005



NEW

BASE PLATE STEEL		M29/M39
Code	Finish	35.0 kg
211009	Black	Ø 800 x 8 mm
211010	Zinc	















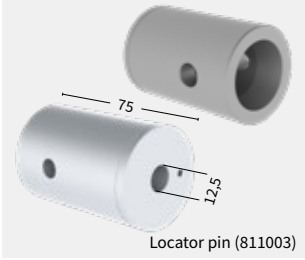

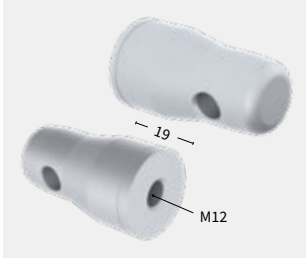
Half connector not included

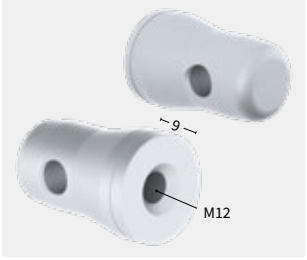
BASE PLATE STEEL		M29/M39
Code	Finish	41.0 kg
211011	Black	800 x 800 x 8 mm
211012	Zinc	

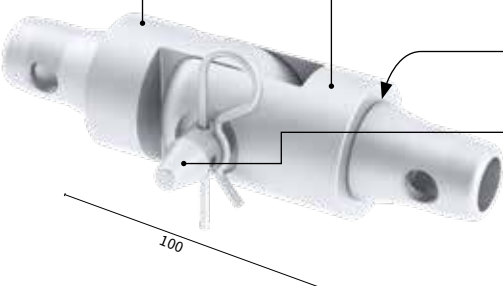

Half connector not included

<p>CONNECTOR M00 202001</p> 	<p>SPIGOT M03 202003</p> 	<p>SPIGOT / THREAD M04 202004</p>  <p>Nut M8 (815001)</p>	<p>R-SPRING M05 202005</p> 														
<p>RECEIVER 75 mm M51 202009</p>  <p>Locator pin (811003)</p>	<p>RECEIVER 105 mm M53 202026</p>  <p>Locator pin (811003)</p>	<p>HALF CONNECTOR M52S 202008</p>  <p>Locator pin (811003)</p>	<p>HALF CONNECTOR M02 202002</p>  <p>M12</p>														
<p>HALF CONNECTOR M50 202010</p>  <p>M12</p>	<p>HALF CONNECTOR M49 202007</p>  <p>M12</p>	<p>SPACER</p> <table border="1"> <thead> <tr> <th>Code</th> <th>Length</th> </tr> </thead> <tbody> <tr> <td>202011</td> <td>2 mm</td> </tr> <tr> <td>202012</td> <td>10 mm</td> </tr> <tr> <td>202013</td> <td>20 mm</td> </tr> <tr> <td>202014</td> <td>30 mm</td> </tr> <tr> <td>202015</td> <td>40 mm</td> </tr> <tr> <td>202016</td> <td>50 mm</td> </tr> </tbody> </table> 		Code	Length	202011	2 mm	202012	10 mm	202013	20 mm	202014	30 mm	202015	40 mm	202016	50 mm
Code	Length																
202011	2 mm																
202012	10 mm																
202013	20 mm																
202014	30 mm																
202015	40 mm																
202016	50 mm																
<p>HINGE MALE 202019</p>  <p>Locator pin</p>	<p>HINGE FEMALE 202018</p>  <p>Locator pin</p>	<p>HINGE PIN 202020</p> <p>∅ 16 x 50 mm</p> 	<p>LOCATOR PIN 3 x 10 811003</p> 														
<p>COMPLETE HINGE SET 202041</p>  <p>100</p>																	

WALL ADAPTER82



WHY: WALL ADAPTER82

212006

- Unique design
- The width is the same as the truss
- Adjustable position of clamps
- Can be used upright and upside down
- Suitable for triangle, square and rectangular shaped truss
- Can be positioned on an angle
- Suitable for M29S-T en M39R
- Load capacity 500 KG**

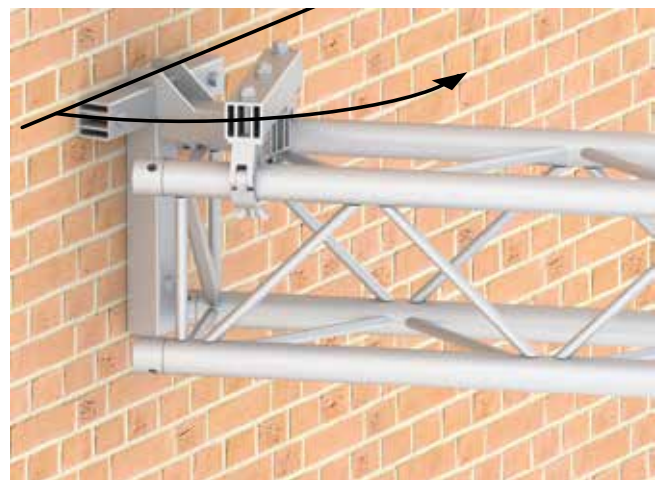

* Connection materials for the wall are not included.

** The individual wall to which the wall adapter will be connected need to be structurally sound to bear the loads.

NEW







50 x 4 mm

Length

 Square	38
 Rectangle	39

Corners

 Square	40
 Rectangle	40

Accessories

40



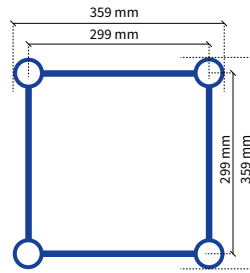

-  12.0 Kg/m
-  ((RFID) READY)
-  L
-  P.100
-  ALU/BLACK

Square - L35S

Code	Length
151001	50 cm
151002	60 cm
151003	80 cm
151004	100 cm
151005	120 cm
151006	150 cm
151007	200 cm
151008	240 cm
151009	250 cm
151010	300 cm
151012	400 cm

Load table L35S

Span m	CPL kg	Deflection mm	2 x load kg	Deflection mm	3 x load kg	Deflection mm	4 x load kg	Deflection mm	UDL kg/m	Deflection mm
2.0	2948.2	3	1865.9	4	1412.9	3	1146.1	4	2303.8	4
4.0	1873.0	12	1216.4	15	995.6	14	822.1	15	1146.5	15
6.0	1380.8	26	929.4	34	778.9	31	597.4	34	595.5	33
8.0	1085.3	47	747.2	60	595.8	56	465.6	60	330.3	58
10.0	886.2	73	620.1	93	477.9	87	378.1	93	207.5	91
12.0	741.7	105	525.7	134	394.9	125	315.3	134	140.8	132
14.0	630.9	143	452.0	183	332.7	170	267.5	183	100.6	179
16.0	542.6	187	392.6	239	284.0	222	229.7	239	74.5	234
20.0	408.3	292	300.8	373	211.2	347	172.6	373	43.8	365

Cantilever load

Span m	1 x Load kg	Deflection mm	UDL kg/m	Deflection mm
0.5	2120.6	0	4618.3	0
1.0	1470.3	1	2114.9	1
1.5	1131.1	3	1163.5	2
2.0	931.9	8	730.8	5
2.5	790.6	17	501.9	8
3.0	684.8	30	372.6	13
3.5	602.4	49	287.3	18
4.0	536.4	75	228.0	25

Multiple supported span

Span m	CPL kg	Deflection mm	2 x Load kg	Deflection mm	UDL kg/m	Deflection mm
2.0	2971.0	1	1586.3	1	1828.5	1
4.0	2005.9	4	1097.8	3	670.1	3
6.0	1537.5	10	837.4	9	340.7	8
8.0	1246.2	19	682.7	17	211.6	15
10.0	1038.2	31	571.1	28	143.2	25
12.0	880.9	46	486.0	41	102.5	37
14.0	756.6	62	418.5	56	76.2	51
16.0	655.2	80	363.1	73	58.2	66
20.0	497.3	119	276.5	108	35.7	112

 Find complete loading tables on SIXTY82.nl

All loading data is based on calculations per EN-1999-1-1 and the following assumptions:

- Static loads only.
- Spans supported or suspended at both ends.
- Triangle trusses solely used apex-up, apex-down.
- 2 chords truss to be placed upright, supported from top chord and loaded from bottom chord.
- Truss spans can be constructed of elements of different length.

- Interaction between bending moment and shear force considered.
- Self-weight of truss is already considered.
- Assembled truss systems need an individual structural calculation. Please contact SIXTY82 or a structural engineer.
- Read the manual before use.
- Higher loading can be allowed depending on the truss configuration.



50 x 4 mm

Length Rectangle

L35R

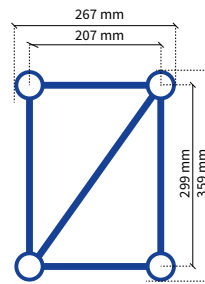

11.0 Kg/m

((RFID) READY)

L

P.100

ALU/BLACK

Rectangle - L35R

Code	Length
154001	50 cm
154002	60 cm
154003	80 cm
154004	100 cm
154005	120 cm
154006	150 cm
154007	200 cm
154008	240 cm
154009	250 cm
154010	300 cm
154012	400 cm

Load table L35R

Span	CPL	Deflection	2 x load	Deflection	3 x load	Deflection	4 x load	Deflection	UDL	Deflection
m	kg	mm	kg	mm	kg	mm	kg	mm	kg/m	mm
2.0	2948.5	3	1866.3	4	1413.3	3	1146.6	4	2305.1	4
4.0	1874.3	12	1217.2	15	996.5	14	822.7	15	1147.8	15
6.0	1383.3	26	930.9	34	780.4	31	598.6	34	596.9	33
8.0	1088.9	47	749.5	60	598.0	56	467.3	60	331.6	58
10.0	891.1	73	623.2	93	480.8	87	380.3	93	208.8	91
12.0	747.9	105	529.6	134	398.5	125	318.0	134	142.1	132
14.0	638.5	143	456.9	183	336.9	170	270.8	183	101.9	179
16.0	551.5	187	398.4	239	288.9	222	233.5	239	75.8	234
20.0	420.0	292	308.6	373	217.5	347	177.5	373	45.1	365

Cantilever load

Span	1 x Load	Deflection	UDL	Deflection
m	kg	mm	kg/m	mm
0.5	2121.1	0	4619.7	0
1.0	1470.9	1	2116.1	1
1.5	1132.0	3	1164.6	2
2.0	933.1	8	731.7	5
2.5	792.1	17	502.7	8
3.0	686.7	30	373.4	12
3.5	604.7	50	288.2	18
4.0	538.9	75	228.9	25

Multiple supported span

Span	CPL	Deflection	2 x Load	Deflection	UDL	Deflection
m	kg	mm	kg	mm	kg/m	mm
2.0	2972.9	1	1587.3	1	1829.9	1
4.0	2008.4	4	1099.0	3	671.1	3
6.0	1541.4	10	839.5	9	341.5	8
8.0	1251.8	19	685.7	17	212.4	15
10.0	1045.5	31	575.0	28	144.1	25
12.0	889.9	46	490.9	41	103.4	37
14.0	767.4	63	424.4	57	77.2	52
16.0	667.7	82	370.0	74	59.2	68
20.0	513.3	123	285.3	112	36.9	115

Find complete loading tables on SIXTY82.nl

All loading data is based on calculations per EN-1999-1-1 and the following assumptions:

- Static loads only.
- Spans supported or suspended at both ends.
- Triangle trusses solely used apex-up, apex-down.
- 2 chords truss to be placed upright, supported from top chord and loaded from bottom chord.
- Truss spans can be constructed of elements of different length.
- Interaction between bending moment and shear force considered.
- Self-weight of truss is already considered.
- Assembled truss systems need an individual structural calculation. Please contact SIXTY82 or a structural engineer.
- Read the manual before use.
- Higher loading can be allowed depending on the truss configuration.

L35

Corners

50 x 4 mm

L35S BOX CORNER

199008

21.0 kg



RECEIVER

203008

L51

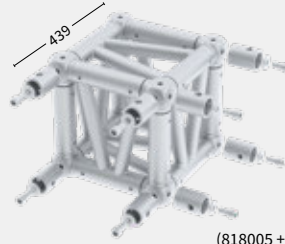

M16x35
(818005 + 818006)

L35R BOX CORNER

199007

15.9 kg



RECEIVER

203008

L51

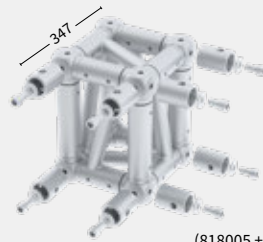

M16x35
(818005 + 818006)

L35

Accessories

BASE PLATE

211008

391 x 391 x 10 mm



Half connector (203002) and bolt (818001) not included

LIFTING BRACKET

212003

L35S

WLL 1000 kg

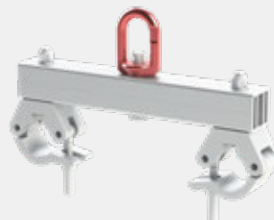

LIFTING BRACKET

212004

L35R

WLL 1000 kg

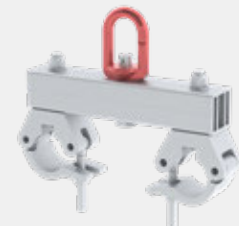

Truss terminology... **what is what?**

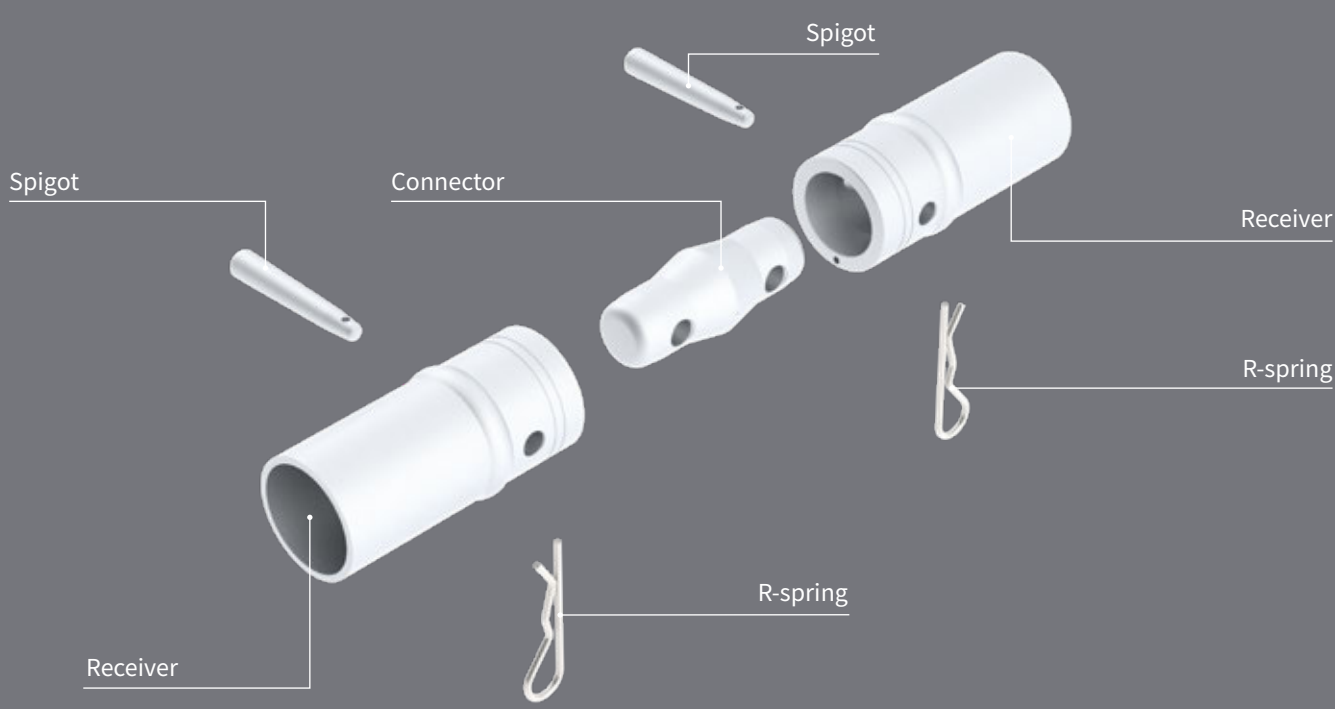
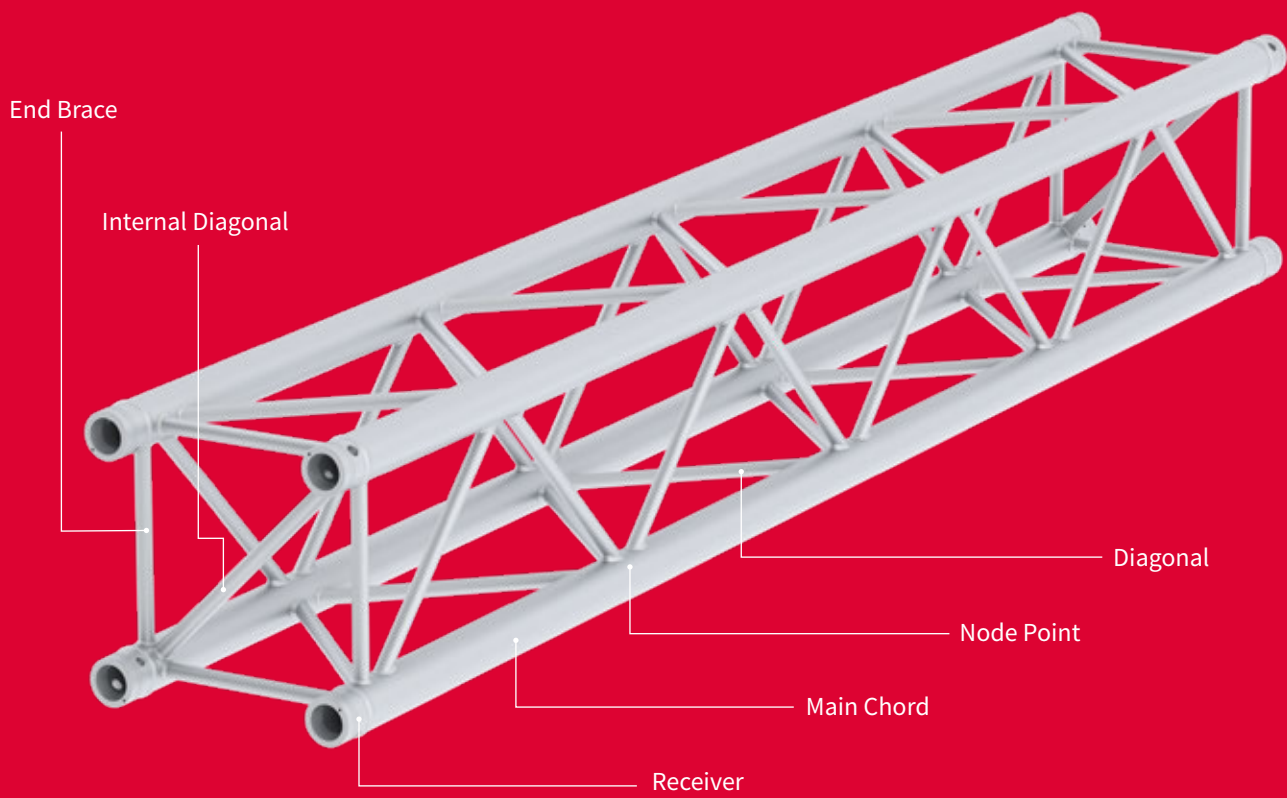

For further information, please refer to the SIXTY82 original user manual.





50 x 4 mm

Length

 Square	44
--	----

Corners

 Square	45
--	----

Circle

 Square	45
--	----

Accessories



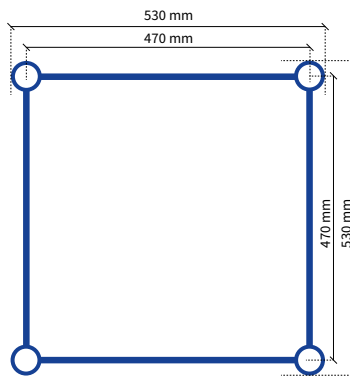
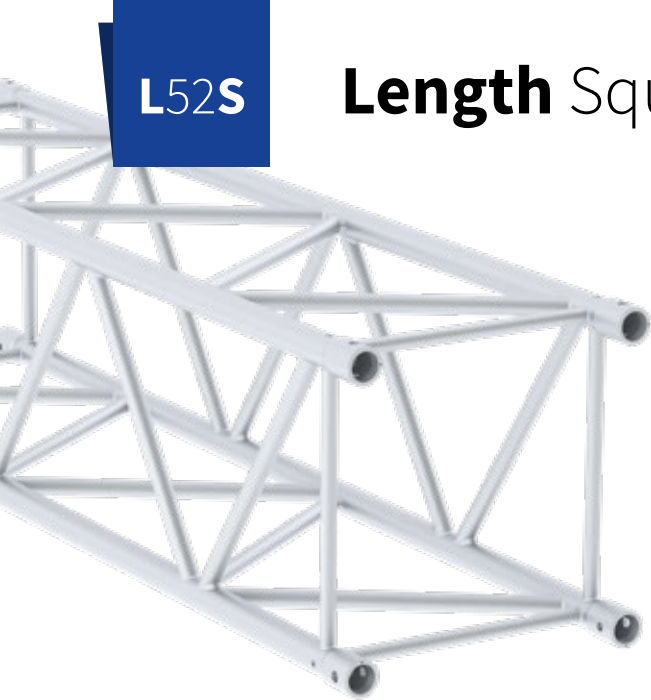

45





Square - L52S

Code	Length
161001	50 cm
161002	60 cm
161003	80 cm
161004	100 cm
161005	120 cm
161006	150 cm
161007	200 cm
161008	240 cm
161009	250 cm
161010	300 cm
161012	400 cm

 15.0 Kg/m  (RFID)
 L  P.100
 ALU/BLACK

Load table L52S

Span m	CPL kg	Deflection mm	2 x load kg	Deflection mm	3 x load kg	Deflection mm	4 x load kg	Deflection mm	UDL kg/m	Deflection mm
2.0	3735.9	2	2215.2	2	1611.5	2	1273.2	2	2827.1	2
6.0	1925.9	17	1245.2	22	1013.9	20	846.0	22	933.4	21
10.0	1296.6	47	877.7	60	725.7	56	559.1	60	329.6	59
14.0	953.6	92	663.6	117	517.3	109	407.2	117	161.6	115
18.0	731.5	152	519.7	194	389.2	180	310.7	194	92.4	190
20.0	646.0	187	463.2	239	341.1	222	273.8	239	72.3	234
22.0	571.9	227	413.7	290	300.1	269	242.1	290	57.4	283
24.0	506.8	270	369.7	345	264.4	320	214.3	345	46.1	337
26.0	448.6	317	330.1	404	232.9	376	189.6	404	37.3	396

Cantilever load

Span m	1 x Load kg	Deflection mm	UDL kg/m	Deflection mm
0.5	2418.3	0	5497.5	0
1.0	1862.0	0	2411.9	0
1.5	1467.1	2	1406.2	1
2.0	1246.3	4	925.7	2
2.5	1082.1	9	654.0	4
3.0	954.3	17	484.6	7
3.5	851.8	28	380.2	10
4.0	767.7	44	306.4	13

Multiple supported span

Span m	CPL kg	Deflection mm	2 x Load kg	Deflection mm	UDL kg/m	Deflection mm
2.0	3425.2	0	1808.2	0	2031.0	0
6.0	2016.4	5	1092.4	5	443.8	4
10.0	1443.8	18	787.8	16	193.3	14
14.0	1095.0	37	601.6	33	107.4	29
18.0	854.3	61	471.6	55	66.4	49
20.0	758.5	74	419.5	67	53.4	68
22.0	674.2	88	373.5	79	43.5	99
24.0	599.0	101	332.4	92	35.6	140
26.0	531.4	114	295.2	103	29.3	193

 Find complete loading tables on SIXTY82.nl

All loading data is based on calculations per EN-1999-1-1 and the following assumptions:

- Static loads only.
- Spans supported or suspended at both ends.
- Triangle trusses solely used apex-up, apex-down.
- 2 chords truss to be placed upright, supported from top chord and loaded from bottom chord.
- Truss spans can be constructed of elements of different length.

- Interaction between bending moment and shear force considered.
- Self-weight of truss is already considered.
- Assembled truss systems need an individual structural calculation. Please contact SIXTY82 or a structural engineer.
- Read the manual before use.
- Higher loading can be allowed depending on the truss configuration.

L52S BOX CORNER

199009

27.4 kg

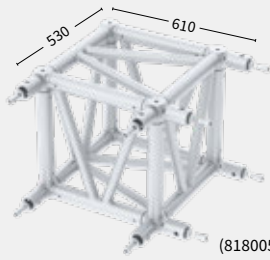
M16x35
(818005 + 818006)**RECEIVER**

203008

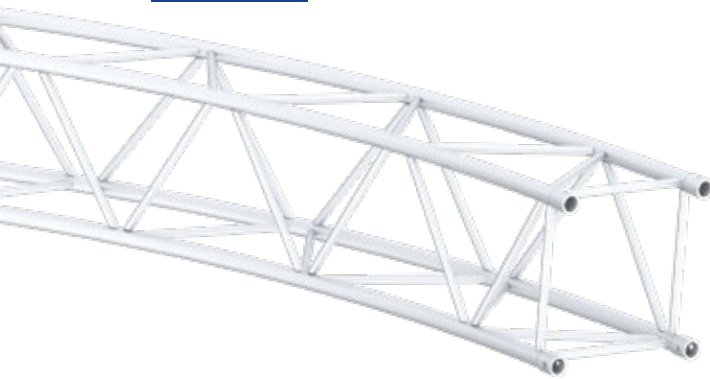
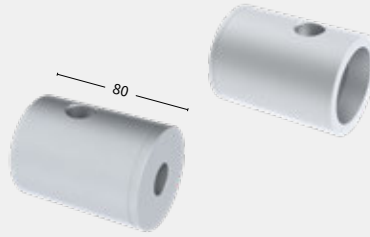
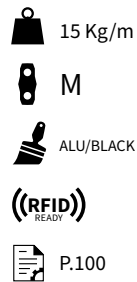
L51**L52S Circle part**

Code	Ø Diameter	Angle	Parts/Circle
163001	3.00 m	90	4
163002	4.00 m	90	4
163003	5.00 m	90	4
163004	6.00 m	90	4
163005	8.00 m	45	8
163006	10.00 m	30	12

- Subject to tolerance, because product is 100% handmade.

BASE PLATE

211007

562 x 562 x 10 mm



Half connector (203002) and bolt (818001) not included

LIFTING BRACKET

212005

L52

WLL 1000 kg

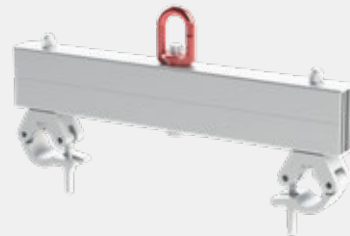

CONNECTOR
203001

L00



SPIGOT
203003

L03



SPIGOT / THREAD
203004

L04



R-SPRING
203005

L05



RECEIVER L80 mm
203008

L51

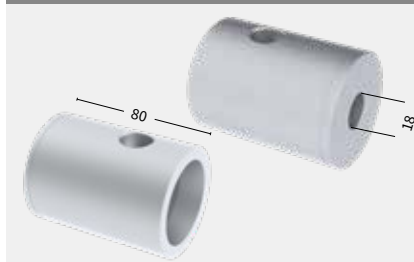

HALF CONNECTOR
203002

L02/16

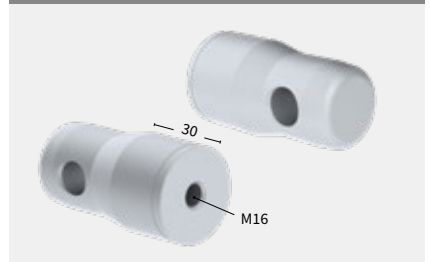

SPACER

Code	Length
203009	2 mm
203010	5 mm
203011	10 mm
203012	20 mm
203013	30 mm
203014	40 mm
203015	50 mm

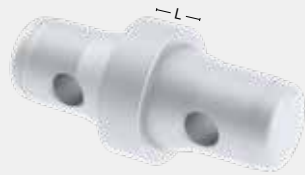









60 x 6 mm

XL101

Length

 Rectangle	50
 Folding	51

Corners

 Rectangle	52
 Folding	52

Accessories



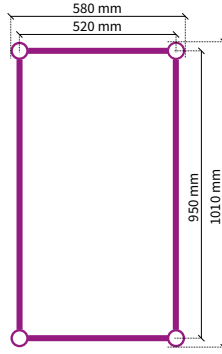

53

S M L XL



Rectangle - XL101R

Code	Length
171001	80 cm
171002	100 cm
171003	120 cm
171004	200 cm
171005	240 cm
171006	250 cm
171007	300 cm
171009	400 cm
171011	480 cm

-  25.0 Kg/m
-  ((RFID))
READY
-  L
-  P.100
-  ALU/BLACK

Load table XL101R

Span m	CPL kg	Deflection mm	2 x load kg	Deflection mm	3 x load kg	Deflection mm	4 x load kg	Deflection mm	UDL kg/m	Deflection mm
4.0	7034.6	4	4261.0	5	3139.5	4	2500.8	5	2993.4	5
12.0	3549.8	33	2322.7	42	1909.9	39	1549.9	42	808.3	41
16.0	2820.5	58	1894.7	74	1592.0	69	1218.3	74	444.8	73
20.0	2309.7	91	1582.3	116	1273.9	108	990.4	116	276.6	114
24.0	1926.6	131	1341.1	168	1044.8	156	821.8	168	185.2	164
28.0	1624.7	179	1146.9	228	869.5	212	690.4	228	130.1	223
32.0	1377.4	233	984.9	298	729.4	277	583.7	298	94.3	291
36.0	1168.6	295	846.1	377	613.3	350	494.3	377	69.8	369
40.0	987.9	364	724.2	465	514.5	432	417.4	465	52.3	455

Cantilever load

Span m	1 x Load kg	Deflection mm	UDL kg/m	Deflection mm
0.5	5483.6	0	11737.1	0
1.0	4712.9	0	5472.8	0
1.5	4047.9	1	3382.1	0
2.0	3500.7	2	2346.6	1
2.5	3058.4	4	1736.7	2
3.0	2771.9	7	1340.4	3
3.5	2532.3	12	1066.0	4
4.0	2328.6	18	867.2	5

Multiple supported span

Span m	CPL kg	Deflection mm	2 x Load kg	Deflection mm	UDL kg/m	Deflection mm
4.0	6638.8	1	3518.0	1	1991.3	1
12.0	3763.9	11	2037.5	10	409.3	8
16.0	3090.1	22	1683.6	19	257.1	17
20.0	2584.5	35	1415.0	31	175.2	28
24.0	2186.3	51	1201.7	46	125.3	53
28.0	1861.0	70	1026.1	63	92.5	98
32.0	1587.5	89	877.6	80	69.8	167
36.0	1352.0	107	749.2	97	53.3	267
40.0	1145.4	125	636.0	113	41.0	400

 Find complete loading tables on SIXTY82.nl

All loading data is based on calculations per EN-1999-1-1 and the following assumptions:

- Static loads only.
- Spans supported or suspended at both ends.
- Triangle trusses solely used apex-up, apex-down.
- 2 chords truss to be placed upright, supported from top chord and loaded from bottom chord.
- Truss spans can be constructed of elements of different length.

- Interaction between bending moment and shear force considered.
- Self-weight of truss is already considered.
- Assembled truss systems need an individual structural calculation. Please contact SIXTY82 or a structural engineer.
- Read the manual before use.
- Higher loading can be allowed depending on the truss configuration.



60 x 6 mm

Length Folding

XL101F

Folding - XL101F

Code	Length
173001	74 cm
173002	80 cm
173003	100 cm
173004	120 cm
173005	200 cm
173006	240 cm
173008	300 cm

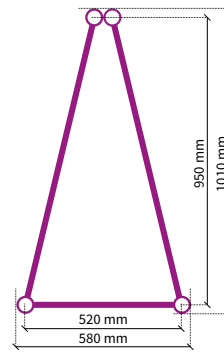

23.0 Kg/m

L P.100

ALU/BLACK



Load table XL101F

Span	CPL	Deflection	2 x load	Deflection	3 x load	Deflection	4 x load	Deflection	UDL	Deflection
m	kg	mm	kg	mm	kg	mm	kg	mm	kg/m	mm
2.4	2598.8	1	1299.4	1	866.3	1	649.7	1	1068.4	1
7.2	2637.7	10	1140.6	13	760.4	12	643.7	13	368.9	13
12.0	1309.2	29	981.9	36	654.6	34	637.8	36	170.5	36
16.8	1516.3	56	1137.2	71	758.2	66	631.8	71	131.6	70
21.6	1092.0	92	819.0	118	546.0	110	455.0	118	91.0	115
26.4	1187.6	138	890.7	176	593.8	164	494.9	176	83.5	172
31.2	1142.3	193	856.7	246	571.2	229	476.0	246	68.9	241
33.6	1020.0	224	765.0	285	510.0	265	425.0	285	64.3	279
36.0	986.2	257	739.7	328	493.1	304	410.9	328	58.7	321

Find complete loading tables on SIXTY82.nl

All loading data is based on calculations per EN-1999-1-1 and the following assumptions:

- Lateral stabilization required every 12m.
- Static loads only.
- Spans supported or suspended at both ends.
- Triangle trusses solely used apex-up, apex-down.
- 2 chords truss to be placed upright, supported from top chord and loaded from bottom chord.
- Truss spans can be constructed of elements of different length.
- Interaction between bending moment and shear force considered.
- Self-weight of truss is already considered.
- Assembled truss systems need an individual structural calculation. Please contact SIXTY82 or a structural engineer.
- Read the manual before use.
- Higher loading can be allowed depending on the truss configuration.

3way



4way



Box



3way



4way



Accessories XL Series

XL

CONNECTOR L00
203001



SPIGOT L03
203003



SPIGOT / THREAD L04
203004



R-SPRING L05
203005



RECEIVER L80 mm L51
203008

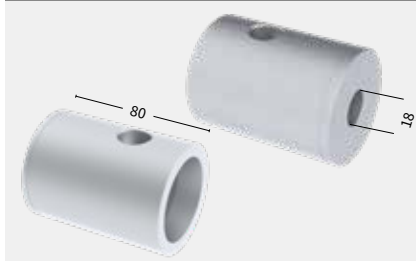

HALF CONNECTOR L02/16
203002 M16

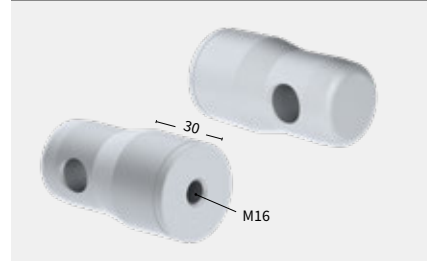

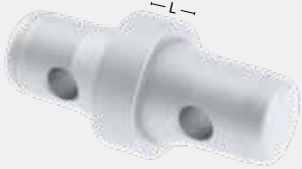
SPACER		
Code	Length	
203009	2 mm	
203010	5 mm	
203011	10 mm	
203012	20 mm	
203013	30 mm	
203014	40 mm	
203015	50 mm	



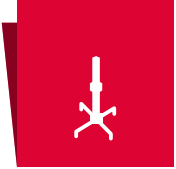

Tower Model M	56
Tower Model L	58
Multibase Tower	60





Tower Model M

M29S
Trussing Tower

Integrated
deadhang:
safe and fast

Alu Base:
see detailed
information
leaflet

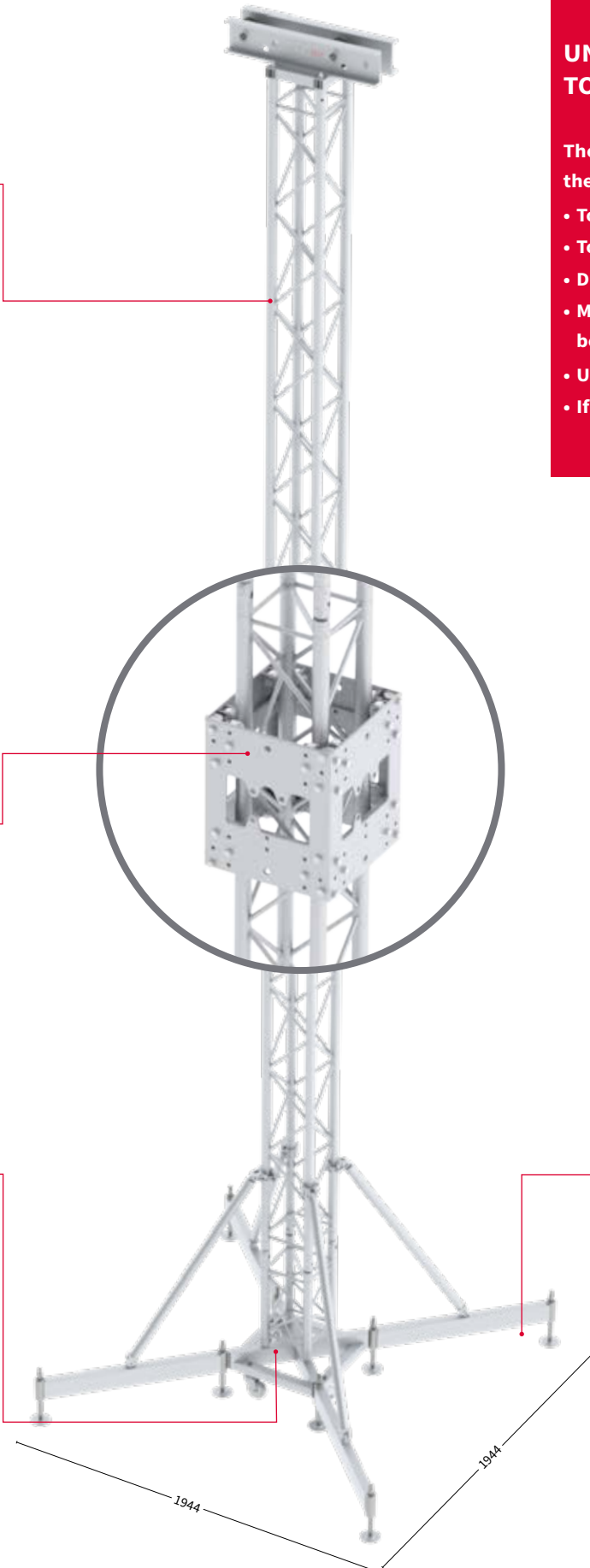

HOW TO?

UNDERSTANDING TOWER LOADING

The following variables determine the allowable tower loading:

- Tower length
- Tower cross sectional dimensions
- Dimension of chords
- Method of restraining top and bottom of the tower
- Use of guy wires
- If the tower base is ballasted

Self-locking
outrigger system:
a unique feature
of the Alu Base



SLEEVE BLOCK PLATED M10
232001 25.2 kg

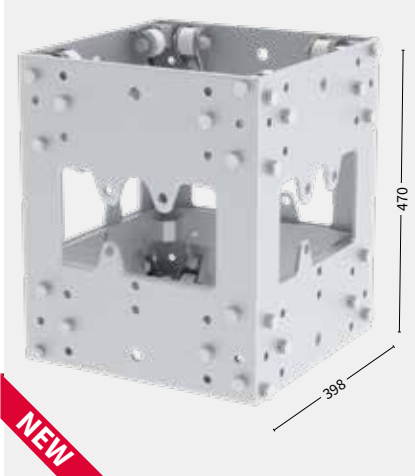

WHY M10 SLEEVE BLOCK PLATED?

- Completely bolted to avoid weakening due to welding
- Lighter weight due to use of special alloys
- Integrated deadhang system
- Deadhang system restrains the sleeve block in 2 directions, therefore optimised for roof systems
- Radiused edges for ease of handling

HEAD SECTION M09
233001 7.3 kg



M29S-Safe-L100 SAFE SYSTEM
232010



M29S-Safe PIN
232011



ALU BASE M04
231001 12.9 kg

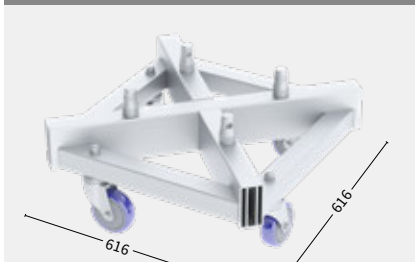

- Lighter due to use of bespoke aluminium extrusions
- Compact design
- Self locking outrigger system
- No moving locking parts

SHORT OUTRIGGER M11
231002 3.1 kg



LONG OUTRIGGER M12
231003 10.1 kg

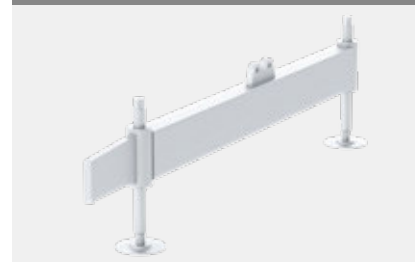

HINGE PART
202041 2.15 kg

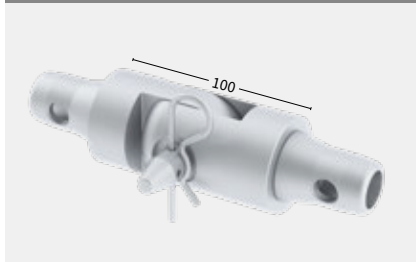

STABILISER M
234005 2.11 kg



Locking pin (202025)



Tower Model L

WHY TOWER MODEL L?

- Light weight sleeve block with minimised welding for optimum strength
- Modular concept allowing multiple configurations
- Tower truss with integrated ladder and diagonal bracing on all sides for optimum strength
- Slim design, less bulky footprint
- Sleeve blocks available for all kind of horizontal truss spans

M39
Trussing Tower

Sleeve Block

Alu base

Long outrigger

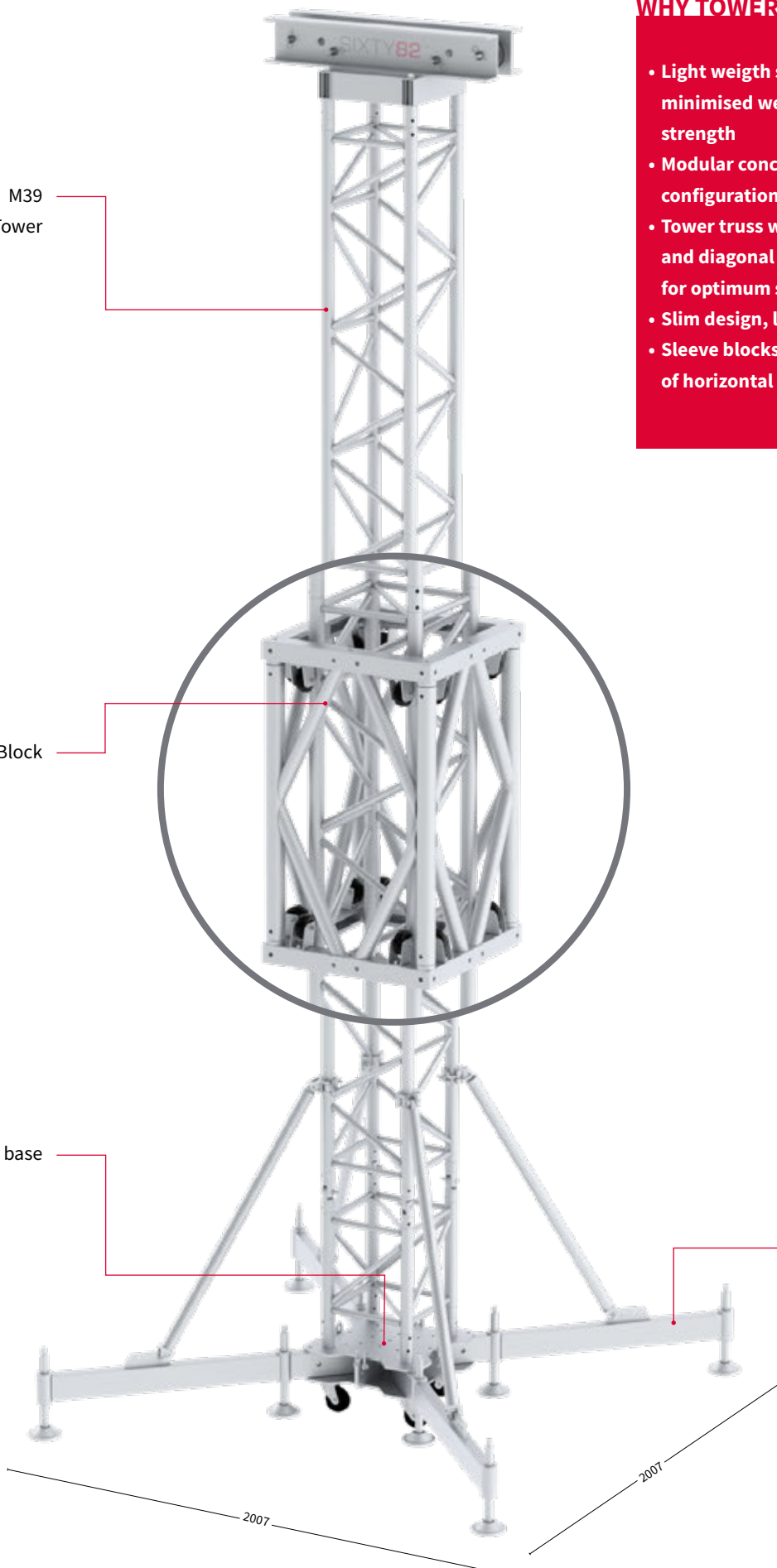



SLEEVE BLOCK L10
232004

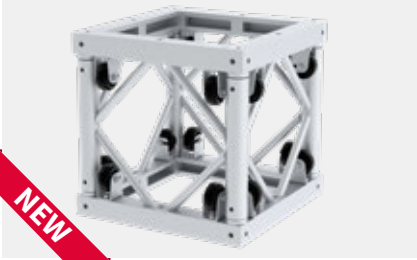

SLEEVE 101R-F
232008



ERECTING SYSTEM TOW MODEL L M39TOW
234007



STABILISER L
234009 27.0 kg



HEAD SECTION L09
233002 27.0 kg



M39TOW

Code	Length
192001	50 cm
192002	100 cm
192003	150 cm
192004	200 cm
192005	250 cm
192006	300 cm
192007	350 cm
192008	400 cm

SHORT OUTRIGGER L11
231005



ALU BASE L04
231004

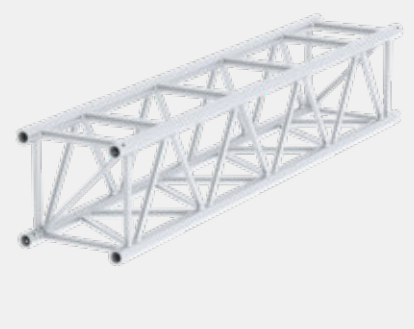

LONG OUTRIGGER L12
231006



HINGE PART
202041 1.75 kg

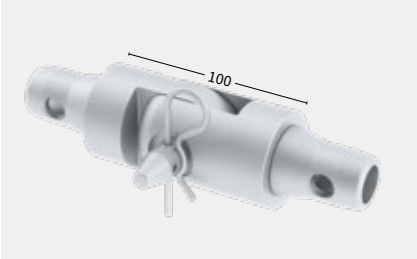



Multibase Tower

NEW

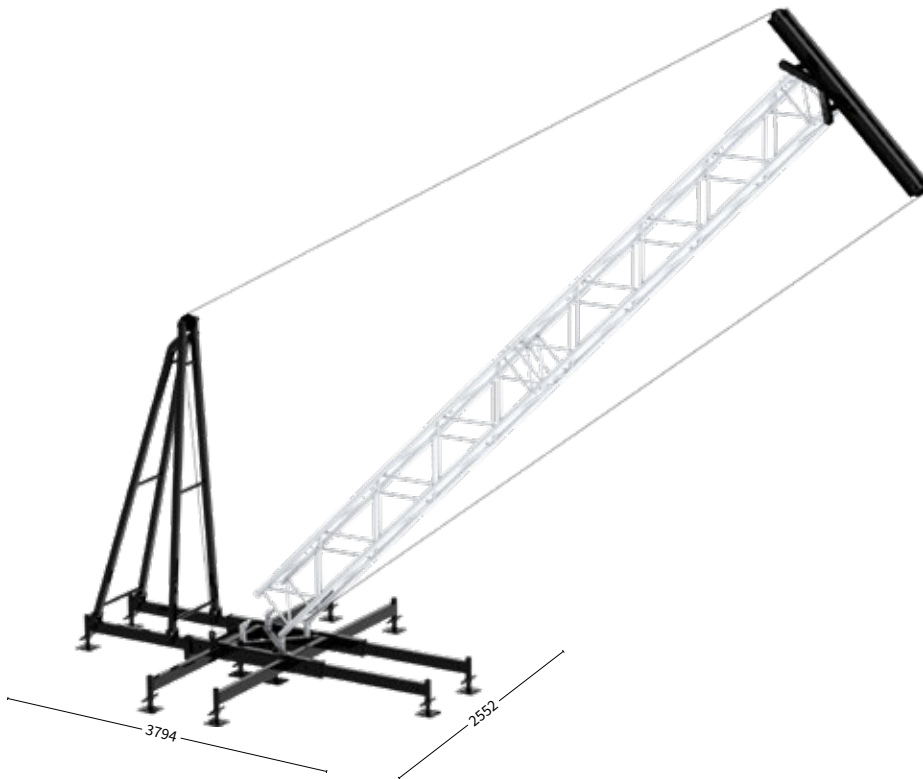

WHY MULTIBASE TOWER?

- Multi usable base for all kind of outdoor structures
- Self erecting by means of chain hoist
- Adapts to many different truss types
- Calculated and proven concept
- Can be used in conjunction with roof systems
- Max foot print 3794 x 2552 mm
- One size fits all head section.. Optional truss head
- Head section comes with multiple suspension points
- Calculated for coastal area (WS4) in Germany

MULTIBASE UNIT

231010

67 kg



MULTIBASE OUTRIGGER 90

231012

M

10 kg

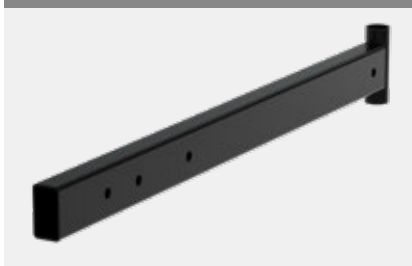

MULTIBASE OUTRIGGER 140

231013

L

22.5 kg



MULTIBASE ERECTING SYSTEM

233012

49 kg



MULTIBASE HOIST BRACKET

234013

5.1 kg

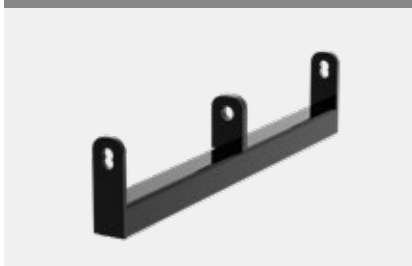

MULTIBASE HEAD SECTION

233005

46 kg



SCAFF SPINDLE

251012

20 CM



L-PIN

203025

16-109





PA Tower *	truss type	tower height **	Max. Pay Load	Front dimensions	Side dimensions	Ballast front	Ballast back	Ballast side	Ballast total	Ballast during erection
Multi Base tower - L52-9.6	L52S	9.6 m	1000 kg	6.0 m ²	3.4 m ²	-	400 kg	2 x 1000 kg	2400 kg	2 x 500 kg
Multi Base tower - M39-8.0	M39S / M39TOW	8.0 m	800 kg	3.5 m ²	2.0 m ²	300 kg	400 kg	-	700 kg	400 kg (back)
Multi Base tower - L35-7.8	L35S	7.8 m	600 kg	3.0 m ²	2.0 m ²	200 kg	400 kg	-	600 kg	400 kg (back)
Multi Base tower - M29-6.0	M29S	6.0 m	500 kg	3.0 m ²	2.0 m ²	200 kg	200 kg	-	400 kg	400 kg (back)
Tech-Tower*										
Multi Base tech tower - L35	L35S / M39S / M39TOW	7.5 m	4 x 150 kg	4 x 1.0 m ²	4 x 1.0 m ²	-	-	2 x 600 kg	1200 kg	
Multi Base tech tower - M29	M29S	6.5 m	4 x 150 kg	4 x 1.0 m ²	4 x 1.0 m ²	-	-	2 x 400 kg	800 kg	
LED Portal (*) (***)										
Multi Base LED Portal L52S - 7x4m	L52S	8.0 m incl. corner	LED 2000 kg PA 2 x 1000 kg	LED 28 m ² PA 2x 4 m ²	-	600 kg	600 kg	1 x 600 kg 1 x 800 kg	2600 kg	600 kg (back)
Multi Base LED Portal M39S - 5.5x3.5m	L35S	7.0 m incl. corner	LED 1000 kg PA 2 x 600 kg	LED 19.25 m ² PA 2x 2.5 m ²	-	400 kg	400 kg	1 x 400 kg 1 x 400 kg	1600 kg	400 kg (back)

* Above data are calculated set-ups. Other options are possible but need to be investigated on a case-by-case basis.

* Baubuch available for shown set-ups.

** Calculations per EN13814:2013 for all wind zones in Germany.

*** Calculations per EN13814:2013 till wind zone 4 in-land in Germany.

Self weight pay load may be subtracted

Max 50% of the pay load may be subtracted

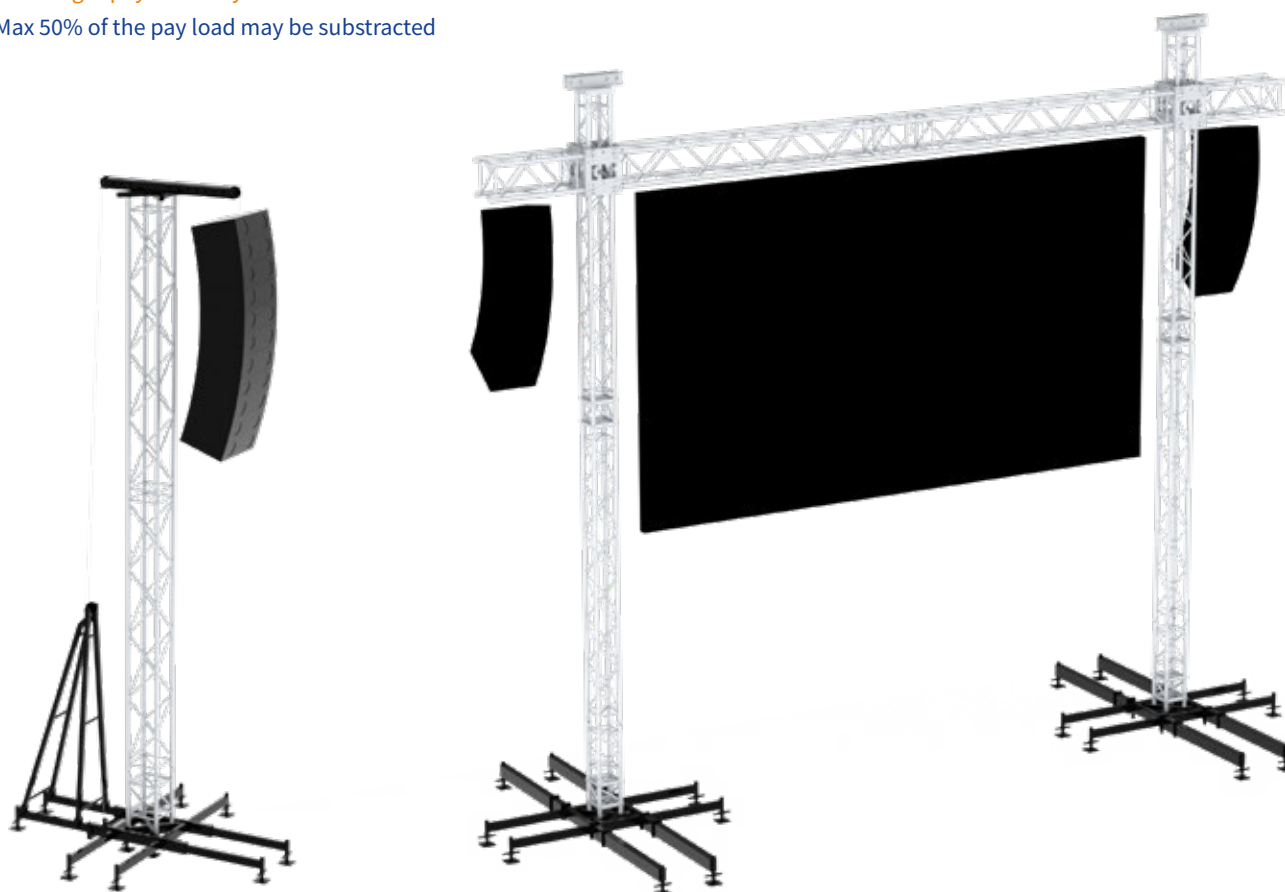





Guadeloupe Roof

64

Arc Roof

66

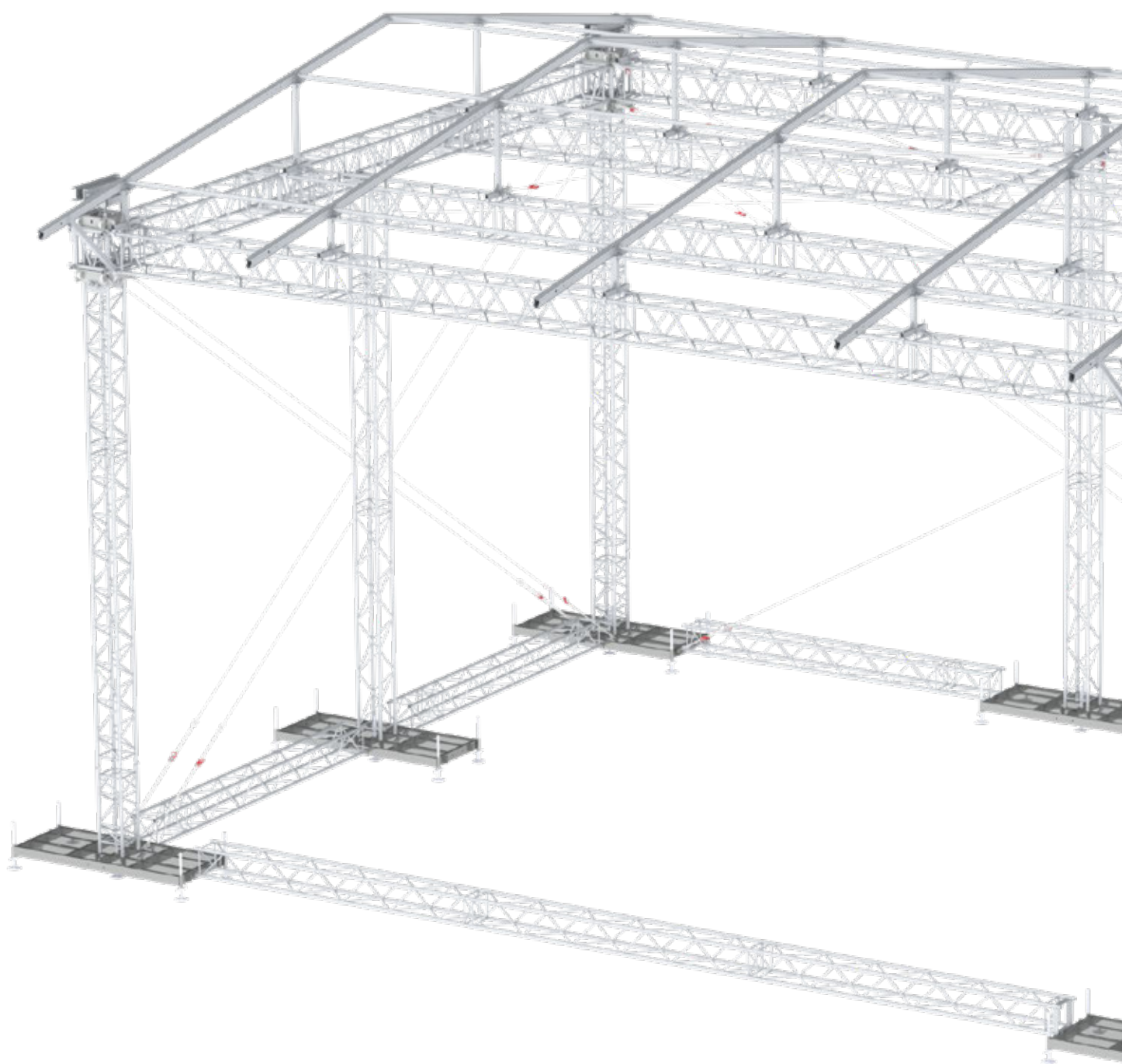



Guadeloupe Roof

NEW



WHY GUADELOUPE ROOF?

- Hurricane proof design (max 40 m/s)
- Canopies sit in kedar profiles for ease of build
- Auto-release system for wall canopies
- Ground ring for reduced ballast
- Bespoke tower bases for correct integration of ballast
- High load capacity
- Full aluminium structure
- Many options for staging or substructure
- Complies with European standards for temporary structures

	15 x 12 meter *
Loading capacity UDL	5645 kg
Loading capacity misc point loads	7000 kg
Loading capacity front cantilever beams	2 x 500 kg
Self weight incl. wall canopies	3197 kg
Max peak gust wind speed in-service	20 m/s (measured at 10 m height)
Max peak gust wind speed out-of-service	28 m/s - 40 m/s
Max peak gust wind during erecting	14 m/s
Ballast	Depends on configuration Bespoke ballast bases
Dimensions structure	W15,08 x D13,96 x H9,93
Dimensions inside for stage platform	14 x 12 m
Trusses	M39S / M39TOW / L52S
Canopy	Standard: grey/ black Optional: transparent
Staging	Several options possible like aluminium scaffolding system StageFrame82
Structural calculations	EN 13814 / Euro codes
Miscellaneous	<ul style="list-style-type: none"> • Canopies fitted in kedar profile • Auto-release system for wall canopies • Optional side wings • Ground ring for reducing ballast • Intermediate support towers for increased loading • Baubuch on request • Structural calculations per DIN-EN-13814

* All data is based on calculated set-up. Other options are possible but need to be investigated on a case-by-case basis.

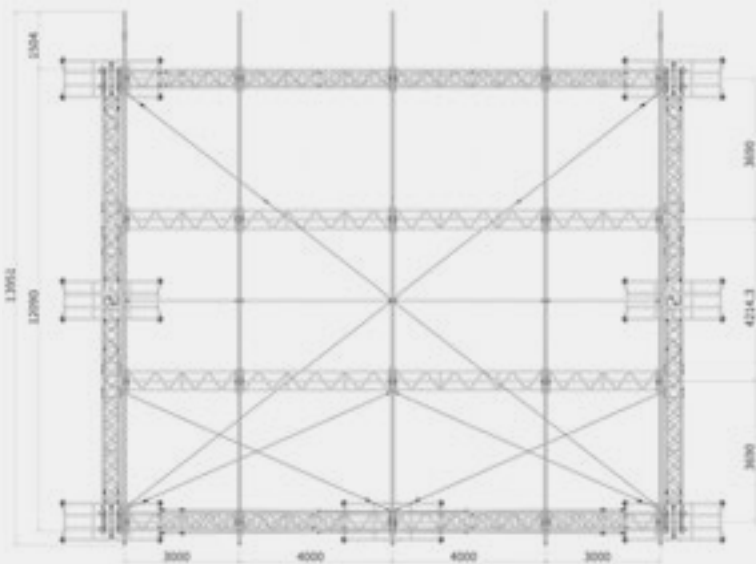
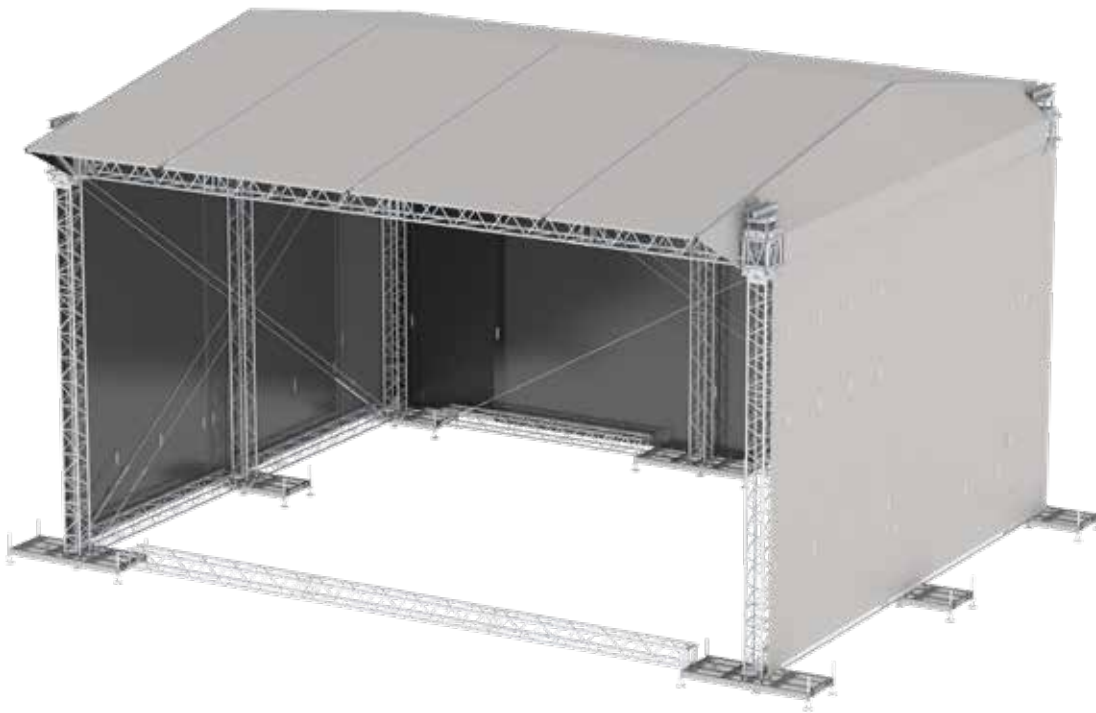

Top view

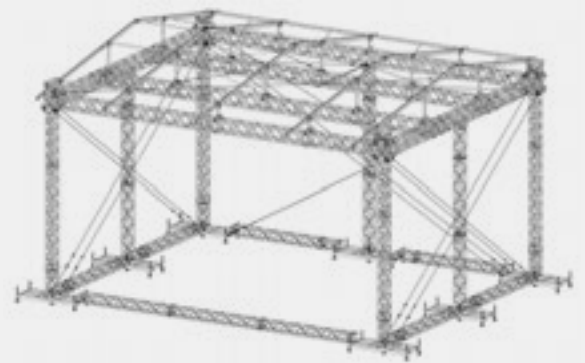

3D view

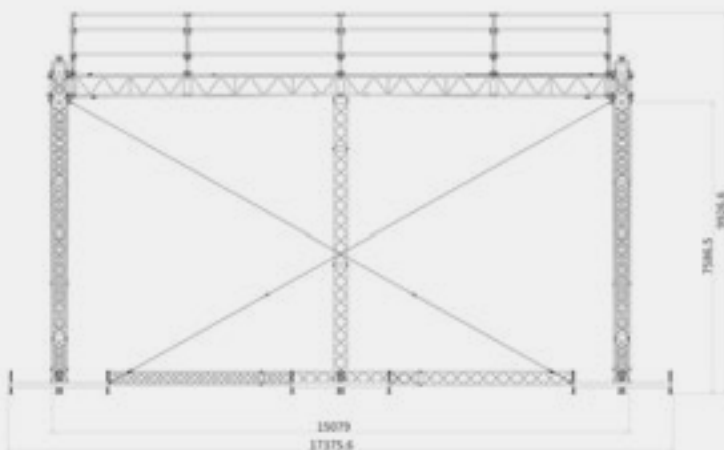

Front view

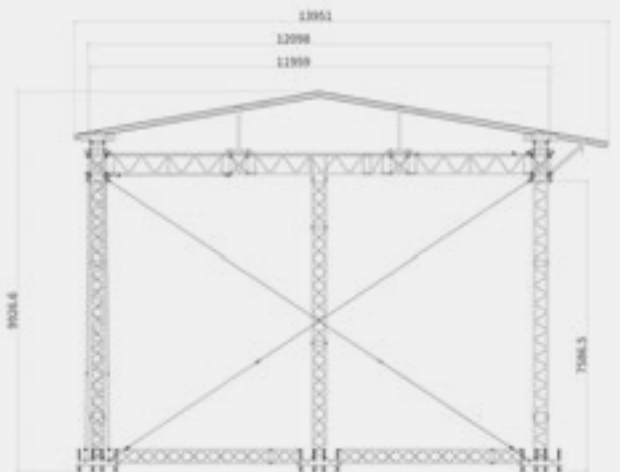

Right view



Arc Roof

NEW

WHY ARC ROOF?

- Versatile contemporary roof structure based on standard trusses
- No obstructing guy wires in sides
- Bespoke corners can be combined with Model M tower sleeve
- Competitively priced
- High loading compared to size
- Easy set-up by hand or material lifts
- Structurally calculated and proven concept
- Full aluminium structure
- Many options for staging or substructure
- Complies with European standards for temporary structures

	6 x 4 meter *	8 x 6 meter*
Loading capacity UDL	2100 kg	2441 kg
Loading capacity front cantilever	2 x 250 kg	2 x 250 kg
Self weight incl. wall canopies	610 kg	682 kg
Max peak gust wind speed in-service	20 m/s (measured at 10 m height)	20 m/s (measured at 10 m height)
Max peak gust wind speed out-of-service	28 m/s	28 m/s
Max peak gust wind during erecting	10 m/s	10 m/s
Ballast	Depends on configuration	Depends on configuration
Dimensions structure	See drawings	See drawings
Dimensions inside for stage platform	6 x 4 m	8 x 6 m
Trusses	M29S / M29T	M29S / M29T
Canopy	Standard: grey/ black Optional : transparent Optional : other colors	Standard: grey/ black Optional : transparent Optional : other colors
Staging	Several options possible like aluminium scaffolding system StageFrame82	Several options possible like aluminium scaffolding system StageFrame82
Structural calculations	EN 13814 / Euro codes	EN 13814 / Euro codes
Miscellaneous	<ul style="list-style-type: none"> • Canopies fitted in kedar profile • No guy wires in side walls • Optional side wings • Baubuch on request • Structural calculations per EN 13814 	<ul style="list-style-type: none"> • Canopies fitted in kedar profile • No guy wires in side walls • Optional side wings • Baubuch on request • Structural calculations per EN 13814

* All data is based on calculated set-up. Other options are possible but need to be investigated on a case-by-case basis.

Arc Roof 6 x 4

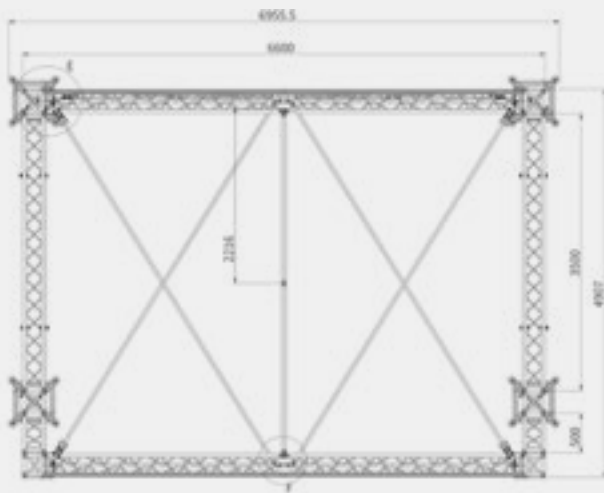
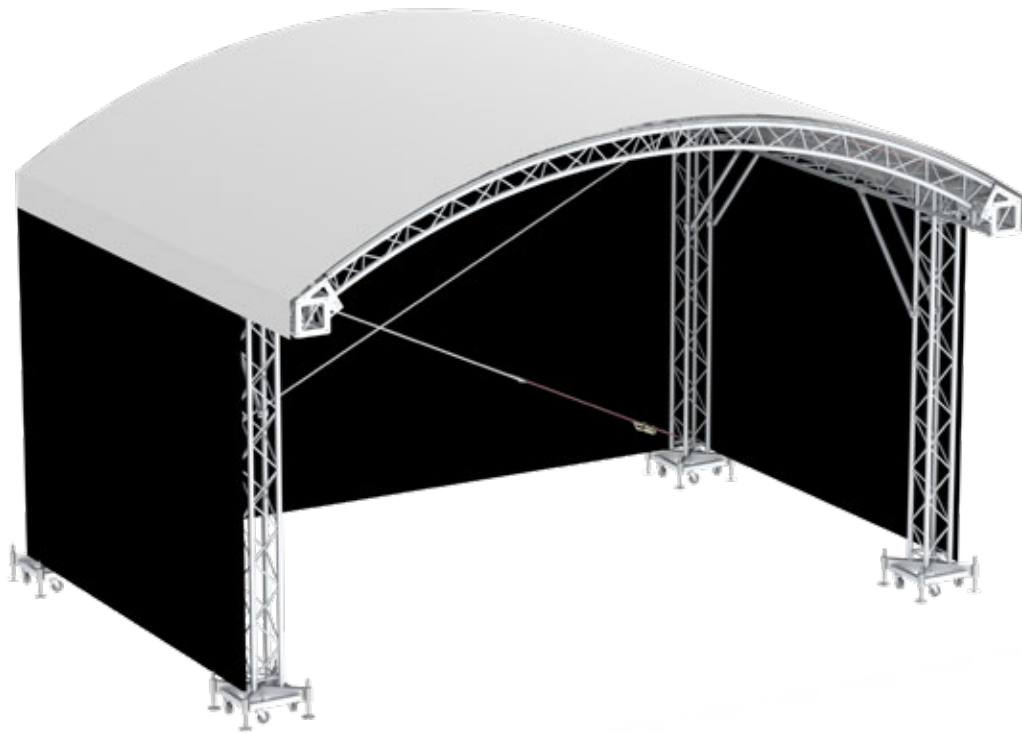

Top view

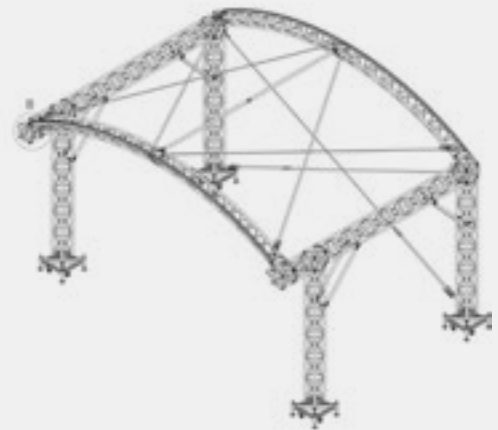

3D view

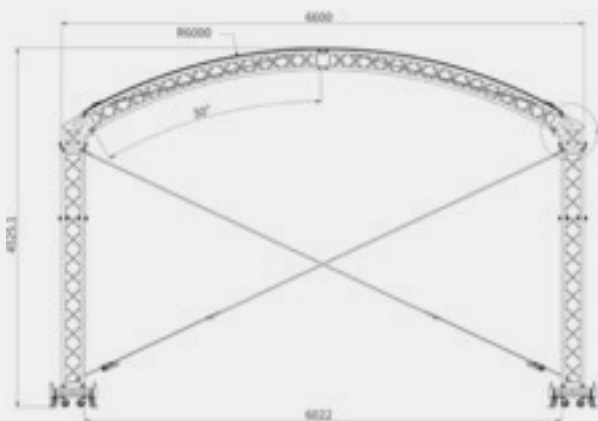

Front view

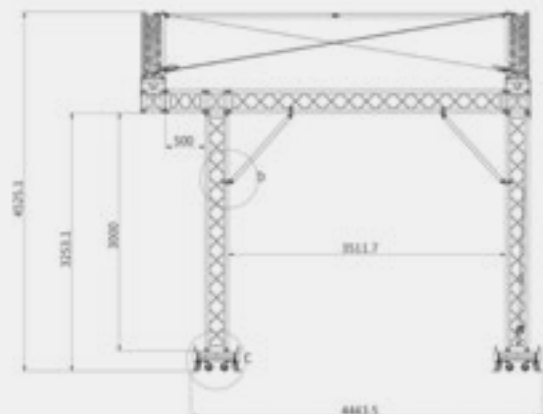

Left view



Arc Roof 8 x 6

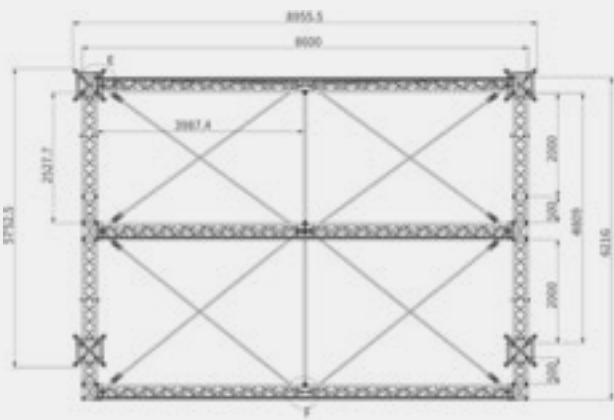
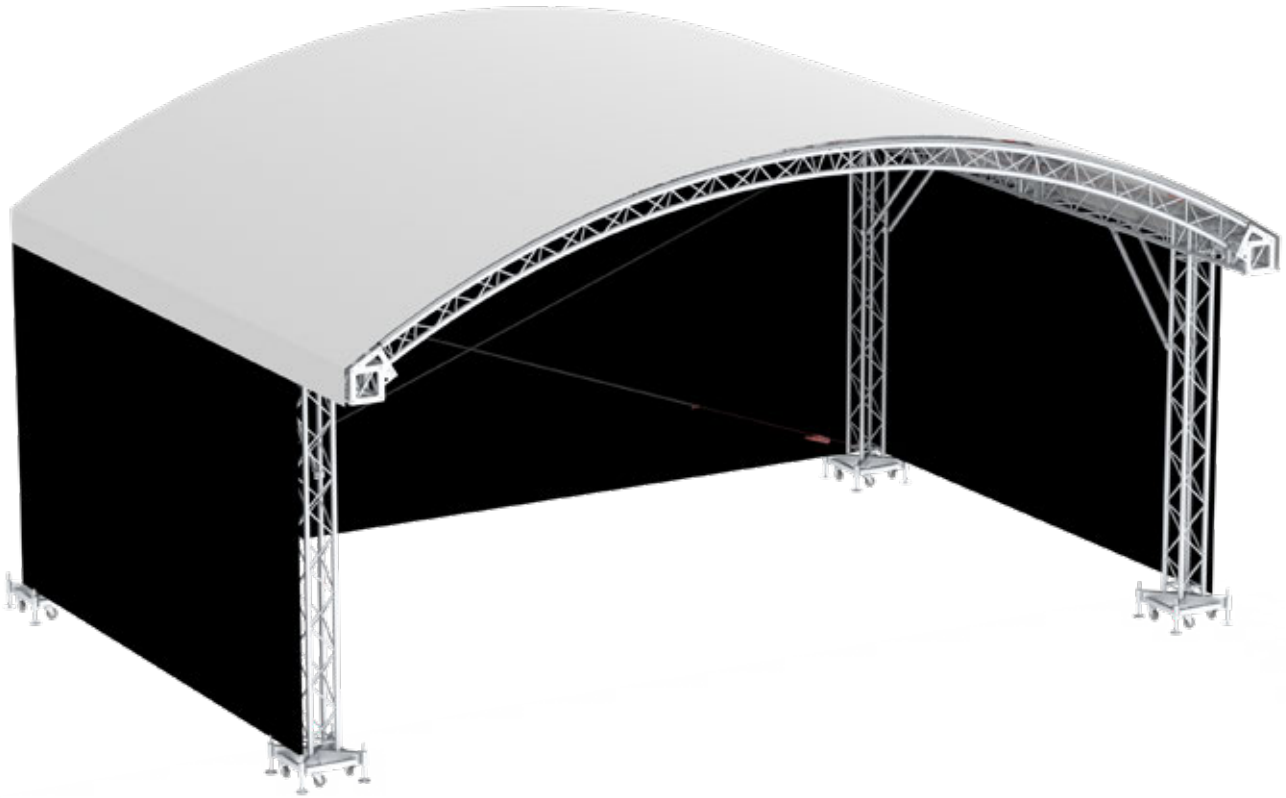

Top view

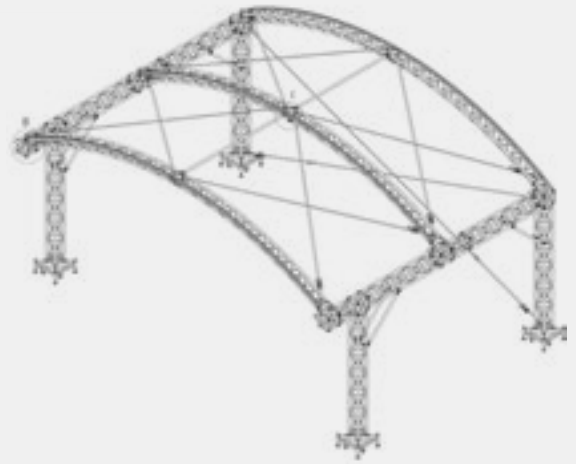

3D view

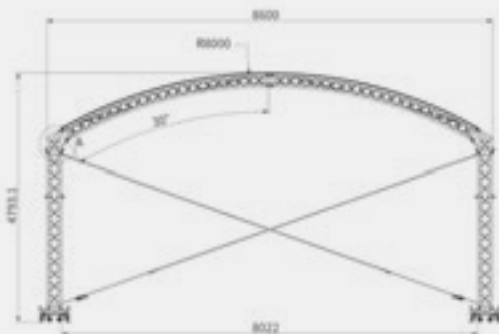

Front view

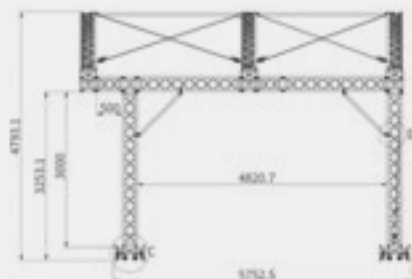

Left view





LED Screen Support



6 x 4 LED Screen Support

72

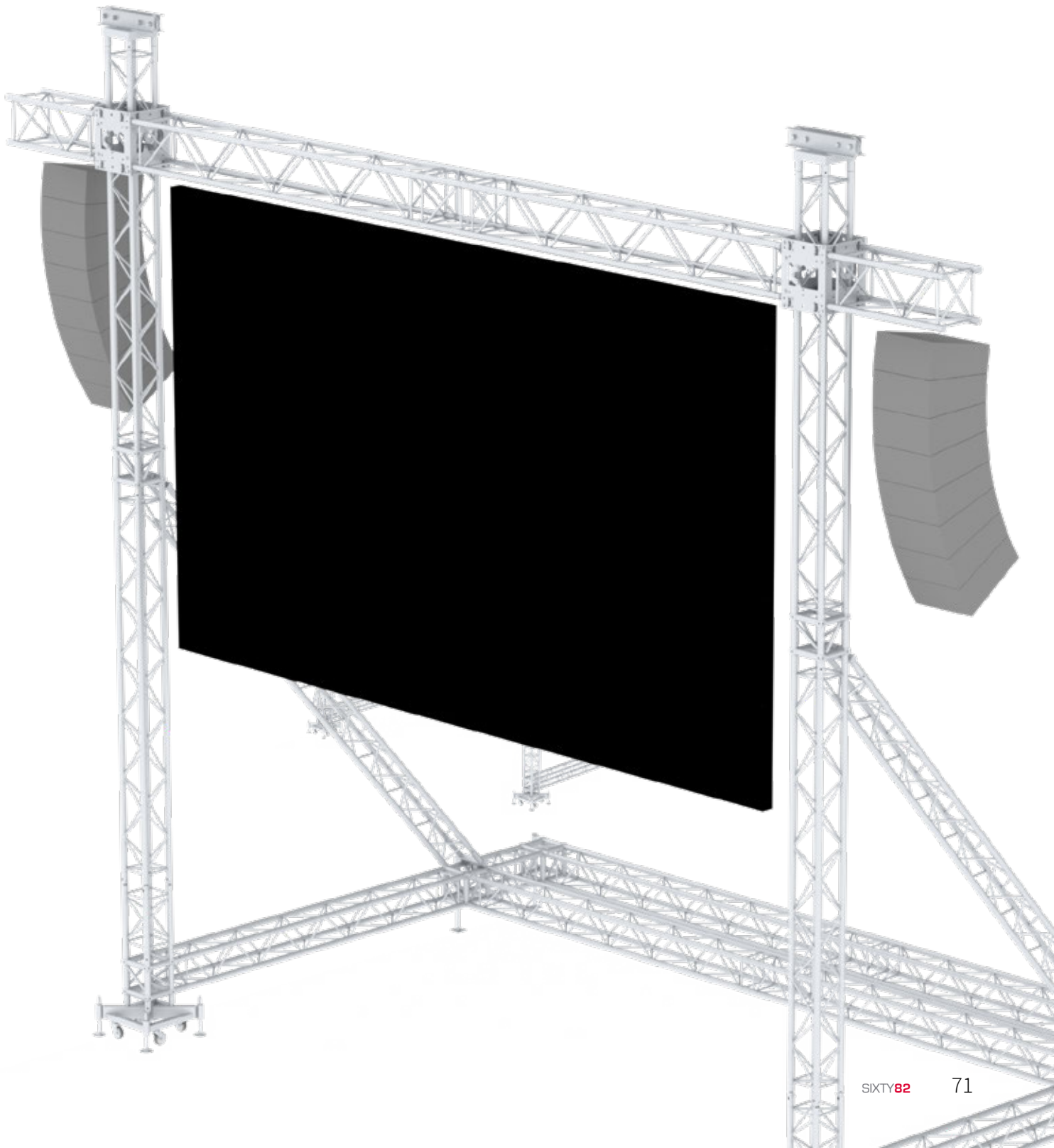



6 x 4 m LED Screen Support

NEW

WHY LED SCREEN SUPPORT?

- Versatile LED Screen Support structure based on standard trusses
- Easy set-up due to fixed base structure
- Structurally calculated and proven concept
- Full aluminium structure
- Intergrated ballast frame for ease of use

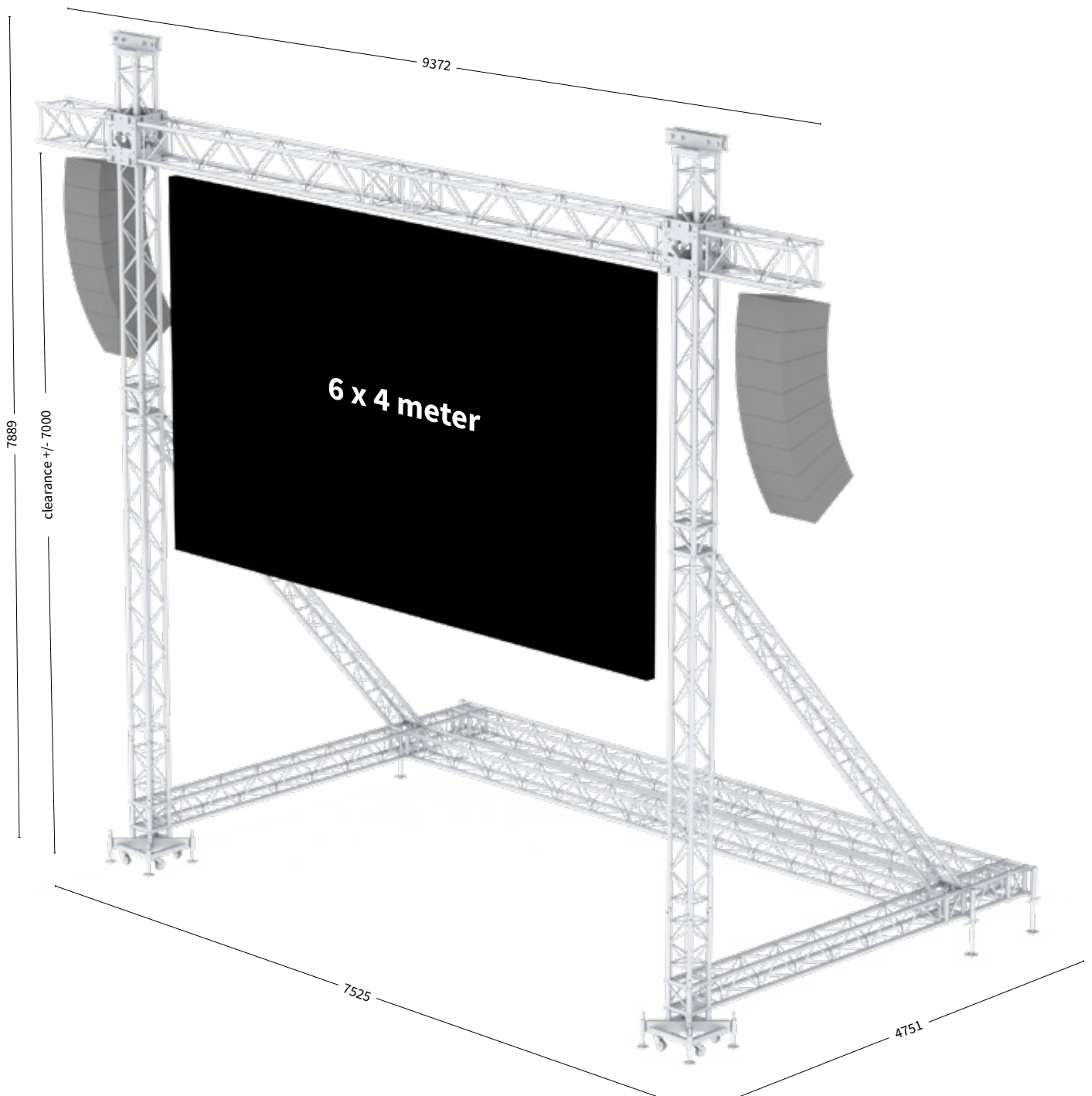



6 x 4 meter	
Max screen size	6 x 4 meter
Max PA size front	1.5 m ²
Max screen weight	1500 kg
Max PA Weight	2 x 250 kg
Max peak gust wind speed in-service	20 m/s (measured at 10m height)
Max peak gust wind speed out-of-service	27 m/s
Max peak gust during lifting	8 m/s
Ballast (if screen weight is 1500kg)	2 x 900 kg
Dimensions	See drawing
Trusses	M29S / M29T / M39S

* Above data based on calculated set-up.
Other options are possible but need to be investigated on a case-by-case basis.

* Calculations per DIN-EN13814:2013 for WS 1-2 in-land in Germany.

* Baubuch on request.

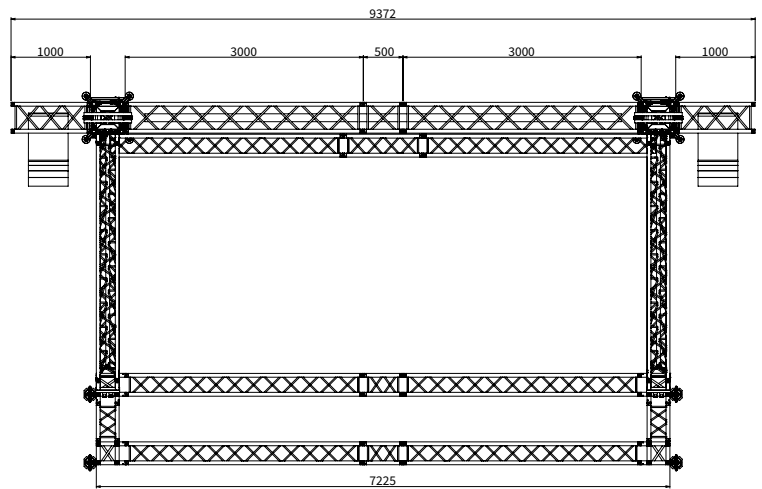

Top view

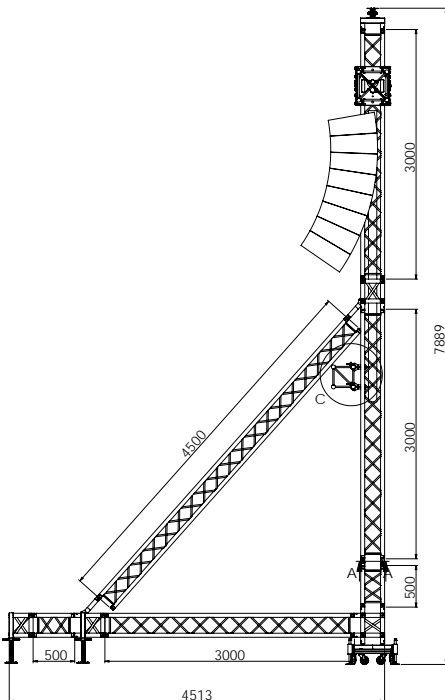

Right view

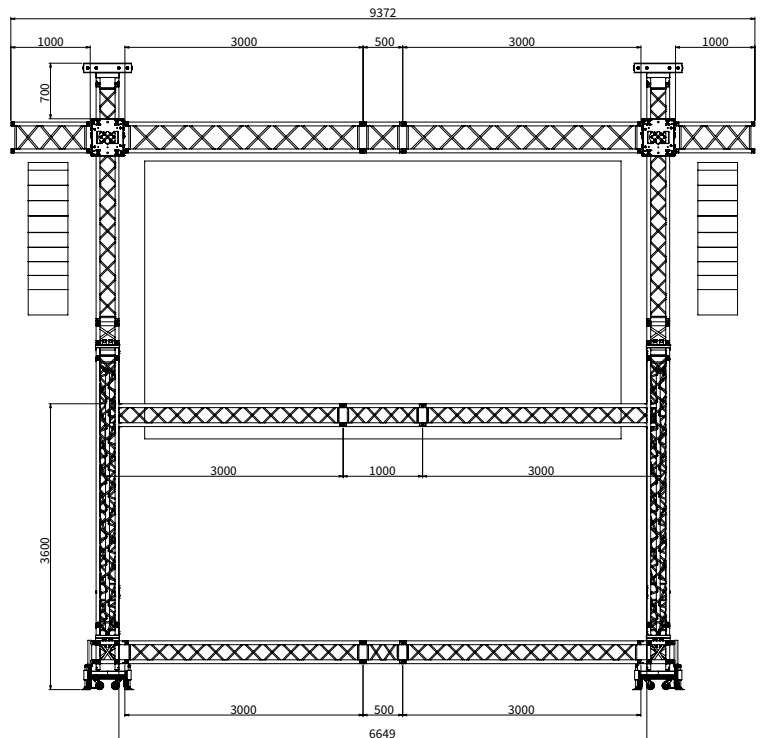

Back view





TUBE	76
BOOTH82	77
STICK82	78
NODE82	79
Truss Dolly	80
Base Plate Dolly	81
Stage Module M Dolly	82
Vario Dolly	83
Railing Dolly	84

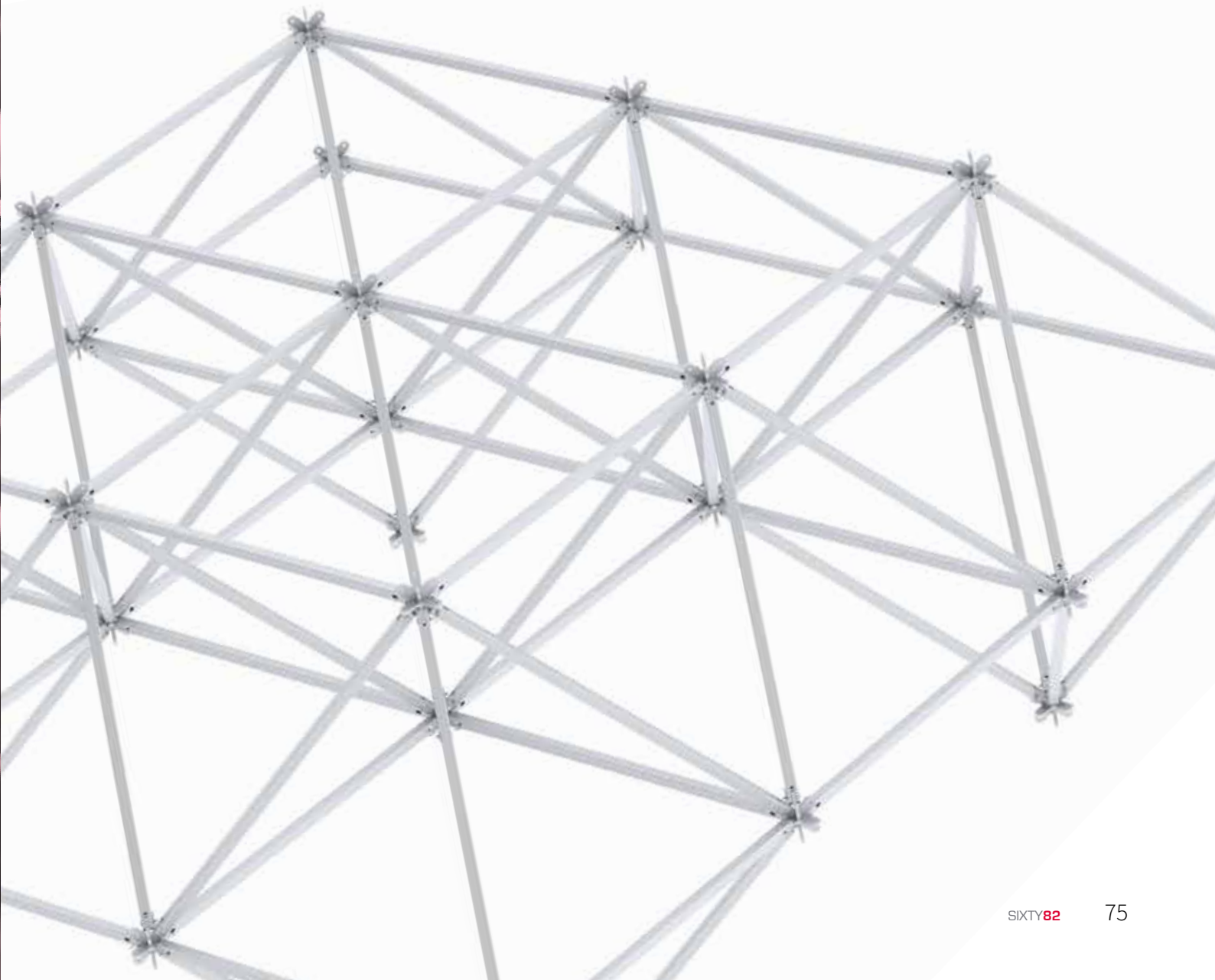



TUBE

TUBE		48.3 x 3 mm
Code	Length	
225001	50 cm	
225002	75 cm	
225003	100 cm	
225006	150 cm	
225004	200 cm	
225007	250 cm	
225005	300 cm	
225008	400 cm	

TUBE with conical coupler		48.3 x 3 mm
Code	Length	
221001	50 cm	
221002	75 cm	
221003	100 cm	
221006	150 cm	
221004	200 cm	
221007	250 cm	
221005	300 cm	
221008	400 cm	

Also available in black

TOP CIRCLE	100 cm
229003	for M29S

Excluding accessories

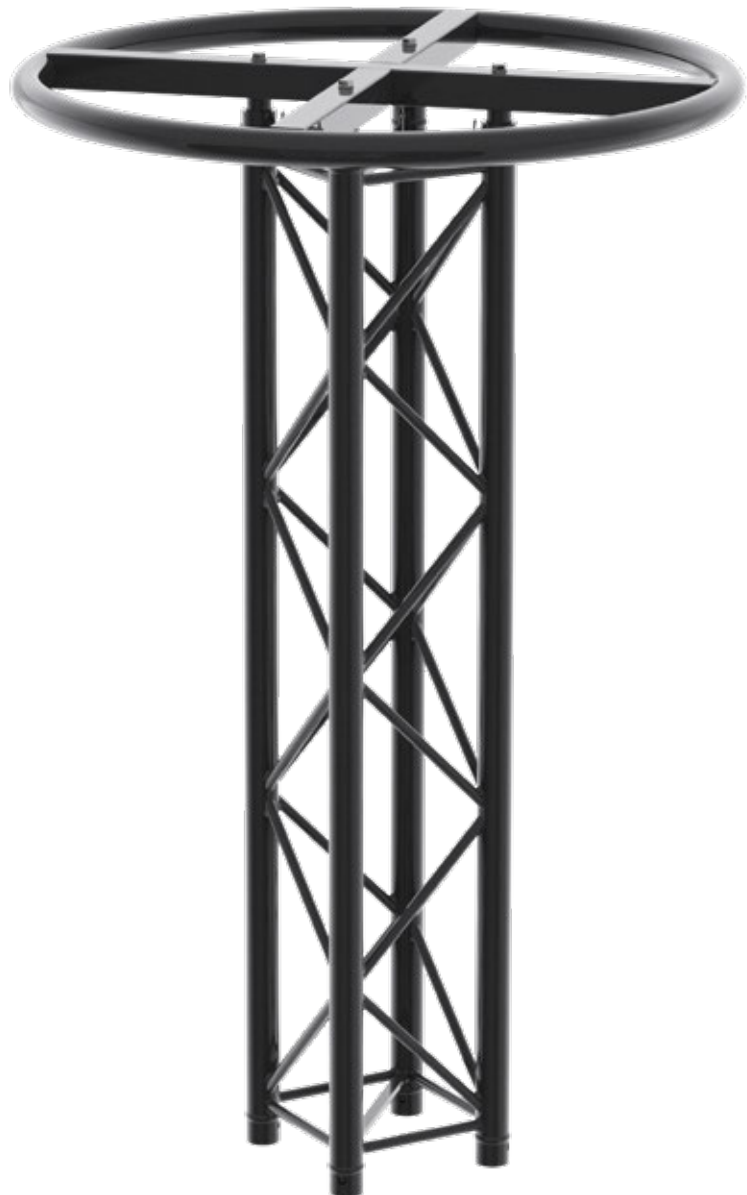



WHY BOOTH82?

- Very compact & light
- Beautiful appearance
- Multi-useable
- Is used in combination with STAGE82
- Easy to transport
- Easy to assemble (one man's job)

BOOTH82
700134

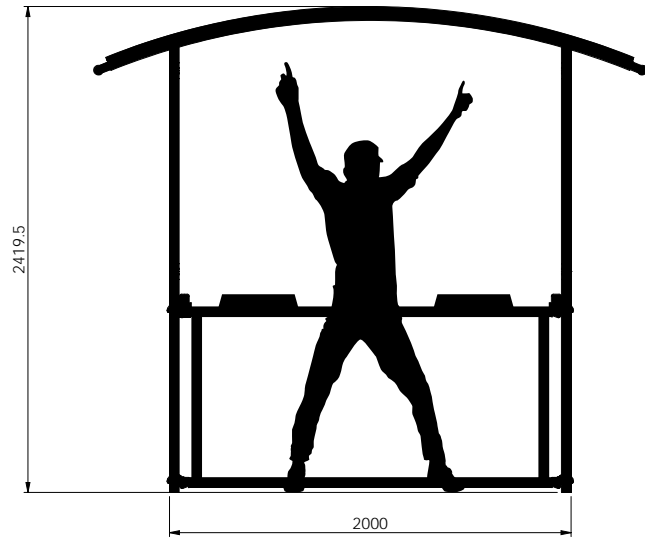

NEW



STICK82

WHY STICK82?

- Complete tower (tube + base)
- Steel base plate (black powder coated)
- Slotted ends allow cables to pass through the tube. Ensuring a clean and finished look for your event

POLE
299002



BASE
299001

18,0 kg

Ø 600 x 8

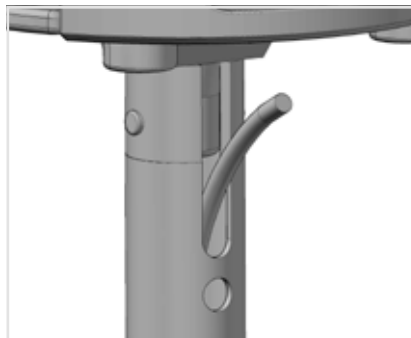

Length 1850

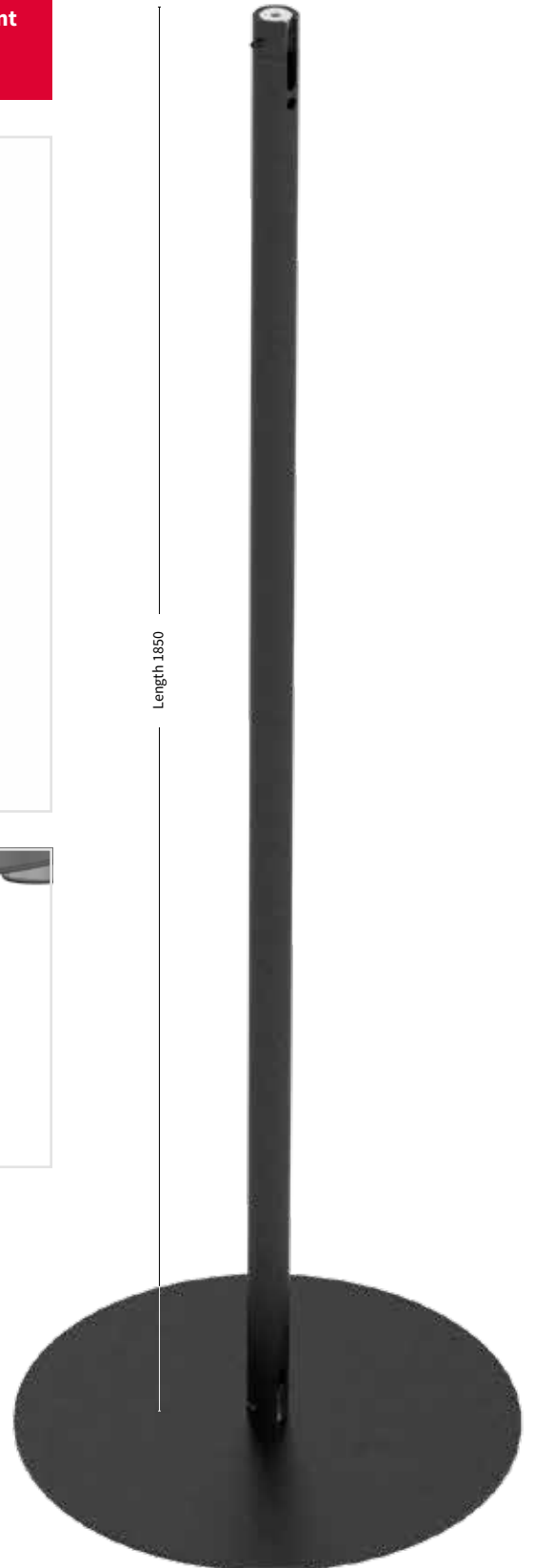



WHY NODE82?

- Create your own 3D structure for all kind of decoration and structural applications
- Extremely versatile
- High load bearing capacity combined with low self weight
- Extremely low transport volume
- Easy to build

Cross 12-Way	189001
Profile 60 cm	189002
Profile 100 cm	189003
Profile 150 cm	189004
Profile 200 cm	189005
Profile 300 cm	189006
R-Spring	202005
Pin M-LP16-44-51	202020

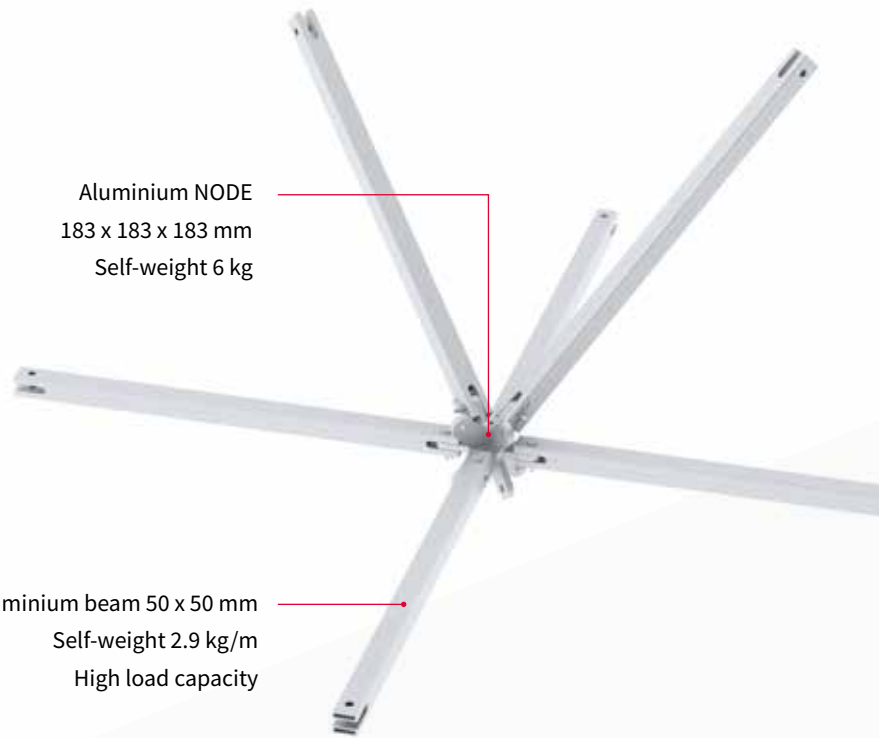

Aluminium NODE
183 x 183 x 183 mm
Self-weight 6 kg

Aluminium beam 50 x 50 mm
Self-weight 2.9 kg/m
High load capacity

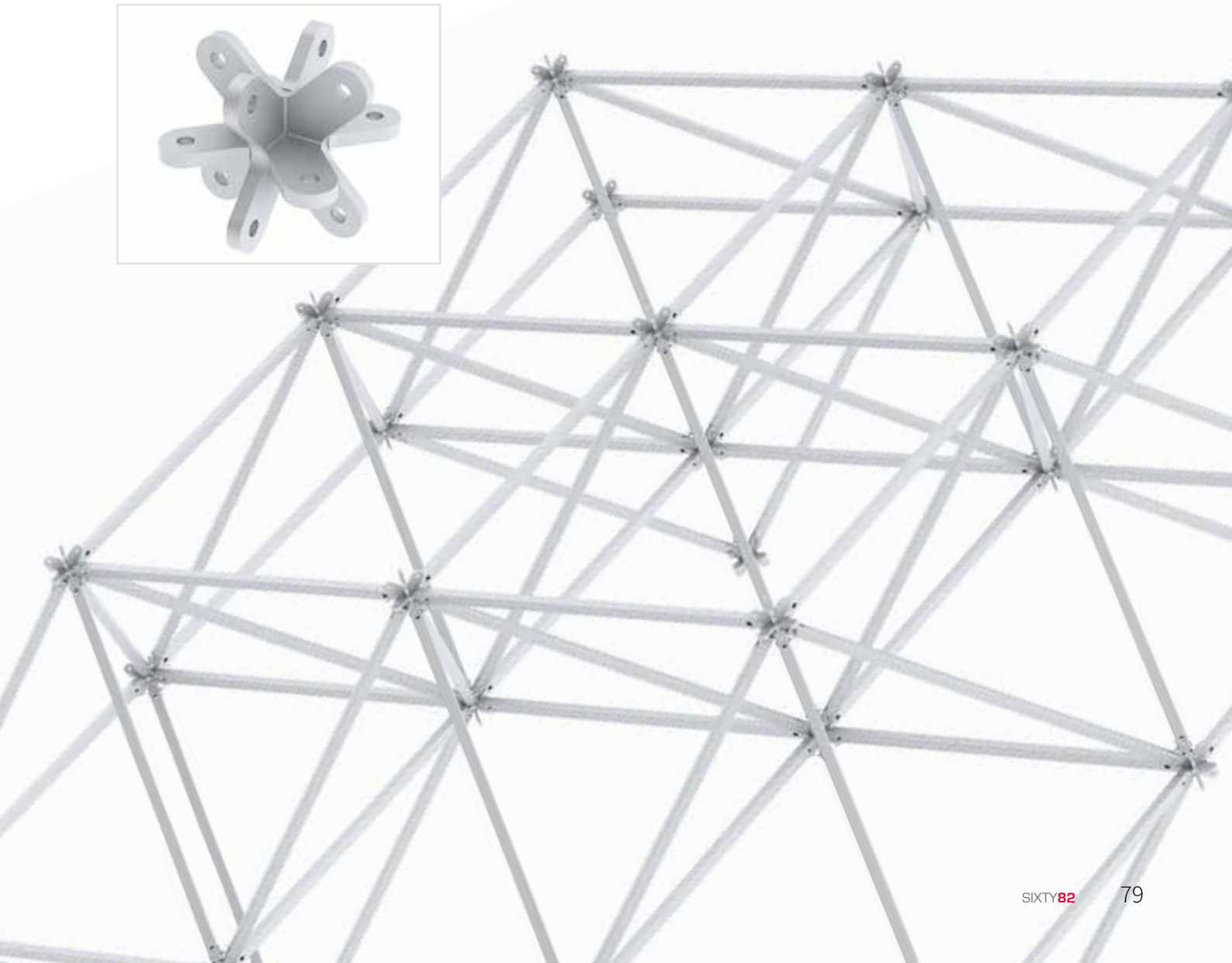



Truss Dolly



Truss Dolly

Code	Type	Weight
215005	290	6.5 kg
215006	390	7.3 kg



Stacking bar double

Code	Type	Weight
215003	M29	1.8 kg
215004	M39	2.5 kg



Stacking bar

Code	Type	Weight
215001	M29	0.5 kg
215002	M39	0.7 kg



Base Plate Dolly



Dolly for 6 baseplates 80 cm round
215011

Aluminium

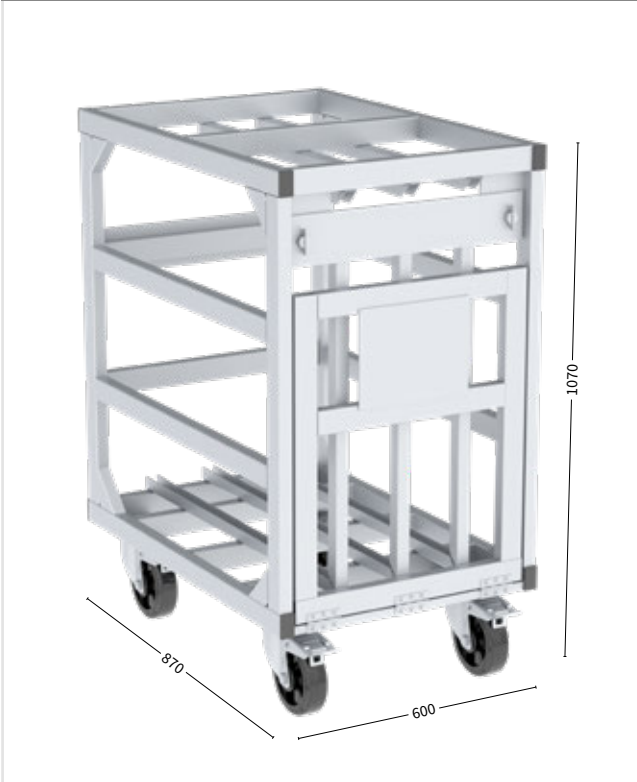

Dolly for 6 baseplates 80 cm square
215012

Aluminium



All measurements are in mm



Stage Module M Dolly

Dolly for 20 stage modules M

215018

48.5 kg



Dolly for 6 stage modules M

215020

41.9 kg



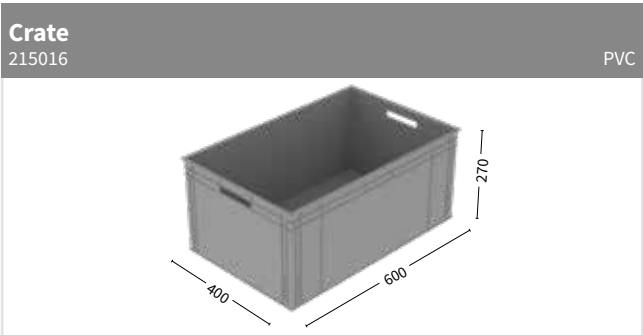
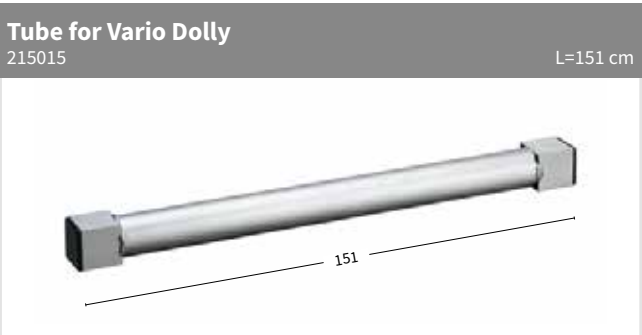
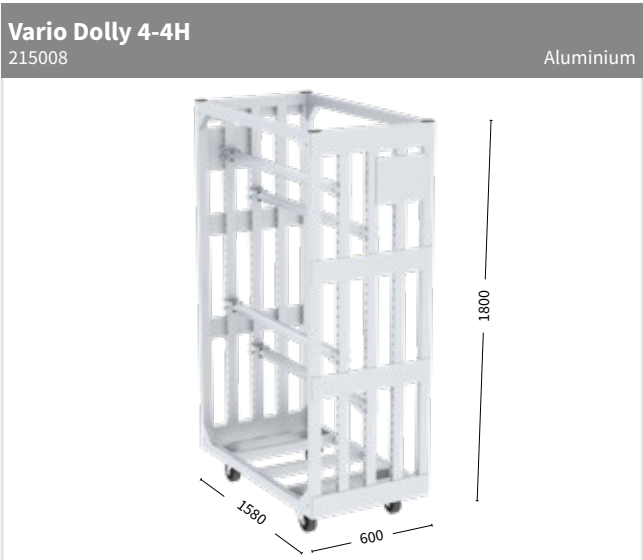



Railing Dolly

Dolly for railing 30 kg/m
215019

52.8 kg



All dollies are available in other sizes.



The New **Original**

Better by Design

Product Personality label and SIXTYTag are both mounted and protected by the bespoke end brace.

Strong Boy

All corners standard with 48.3 x 3 mm main chords.

Universally Unique

Our unique product lines are also used compatible with other brands.

RFID Tracked

Integrated SIXTYTag, enabling RFID product tracking and traceability, always tied to the unique serial number.

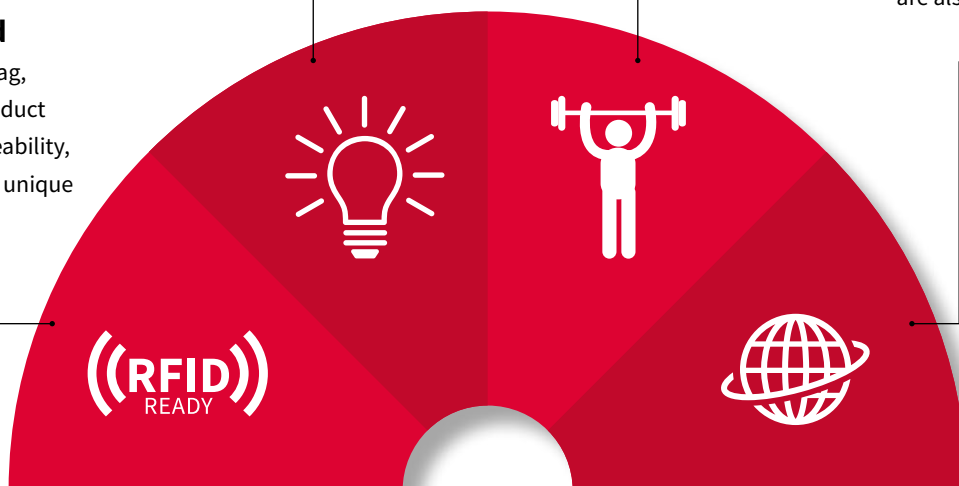





Stage Module M STAGE82	88
Stage Module M Shapes	89
Stage Module L LIVEDECK	91
Stage Module L LIVE82	92
Stage Module L/M Legs	93
Stage Accessories	94
Stairs Adjustable	95
Stairs Modular	96
Stage Railing	97
Skirting	98





Stage Module M STAGE82

WHY STAGE82?

- Sealed gap between wood and extrusion to avoid water intrusion
- Screwed top plate
- Frame design facilitates much easier handling and pick up by hand
- Scaffolding event beam compatible
- Compatible with existing brands
- Double painted plywood topping
- Easy repair as completely bolted



Hexa non slip top



Black painted wood



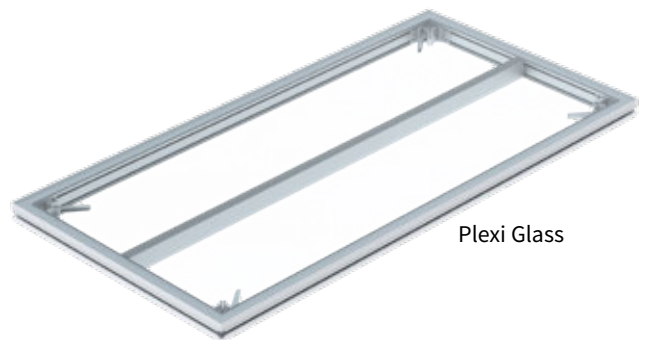

Natural Wood



Plexi Glass

 750 kg/m²

 Lateral loading 10%

 plywood 15 mm

 36 kg (2 x 1 m)

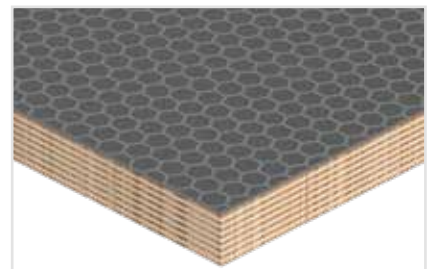

Hexa finish plywood



Leg Pocket open



Leg Pocket closed

Stage Module M Shapes



Rectangular 200 x 100 cm

Product	Code
Black HEXA Plywood / non slip top	310001
Birch Plywood / Black	311001
Birch Plywood / Unfinished	312001

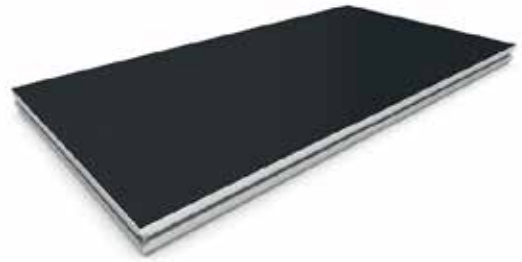

Rectangular 100 x 100 cm

Product	Code
Black HEXA Plywood / non slip top	310002
Birch Plywood / Black	311002
Birch Plywood / Unfinished	312002

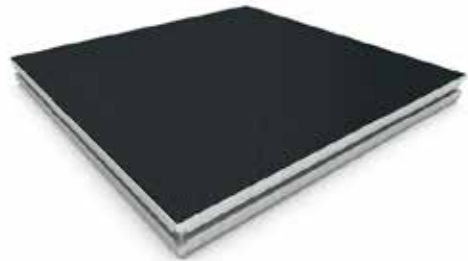

Rectangular 200 x 50 cm

Product	Code
Black HEXA Plywood / non slip top	310003
Birch Plywood / Black	311003
Birch Plywood / Unfinished	312003

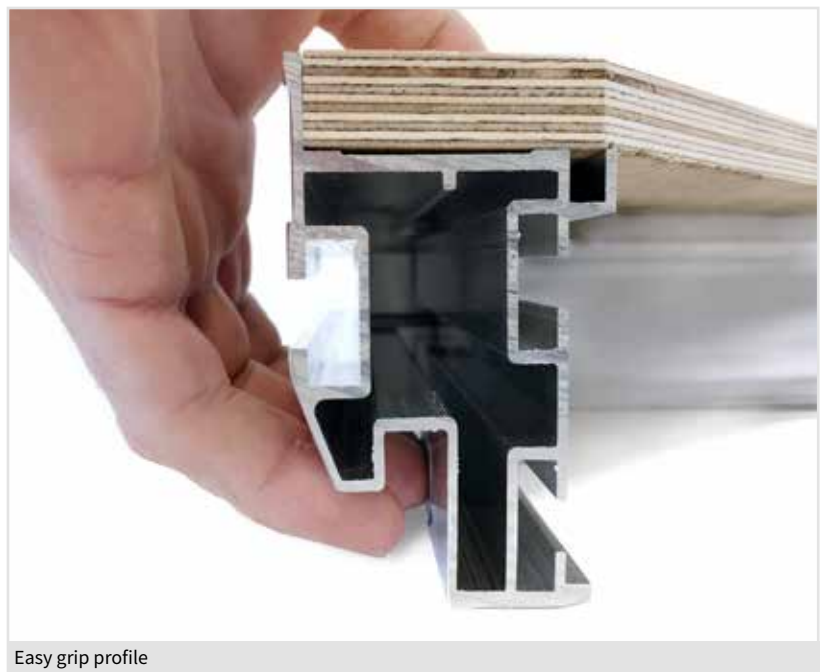
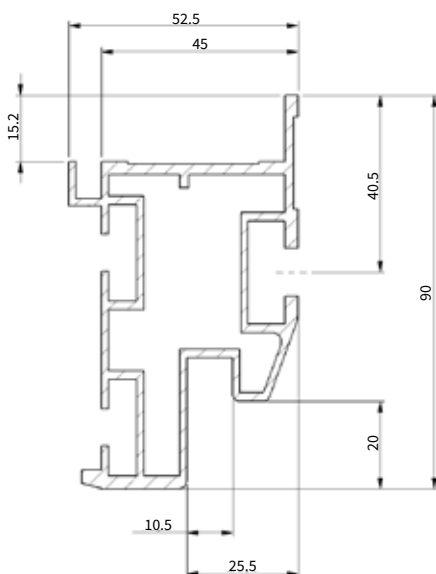



Triangular 200 x 100 cm left

Product	Code
Black HEXA Plywood / non slip top	310005
Birch Plywood / Black	311005
Birch Plywood / Unfinished	312005



Triangular 200 x 100 cm right

Product	Code
Black HEXA Plywood / non slip top	310006
Birch Plywood / Black	311006
Birch Plywood / Unfinished	312006



Triangular 100 x 100 cm

Product	Code
Black HEXA Plywood / non slip top	310007
Birch Plywood / Black	311007
Birch Plywood / Unfinished	312007

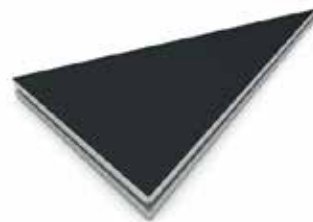

Stage Module L LIVEDECK



Rectangular

Product	Code	Weight
LIVEDECK 8 x 4 ft (2.44 x 1.22 m)	320001	49.0 kg
LIVEDECK 8 x 2 ft (2.44 x 0.61 m)	320002	36.0 kg
LIVEDECK 6 x 4 ft (1.83 x 1.22 m)	320003	33.5 kg
LIVEDECK 4 x 2 ft (1.22 x 0.61 m)	320005	21.0 kg
LIVEDECK Top Lock 8 x 4 ft (2.44 x 1.22 m)	320009	49.0 kg
LIVEDECK Top Lock 8 x 2 ft (2.44 x 0.61 m)	320010	36.0 kg
LIVEDECK Top Lock 6 x 4 ft (1.83 x 1.22 m)	320011	33.5 kg
LIVEDECK Top Lock 4 x 2 ft (1.22 x 0.61 m)	320013	21.0 kg

Square

Product	Code	Weight
LIVEDECK 4 x 4 ft (1.22 x 1.22 m)	320004	27.5 kg
LIVEDECK Top Lock 4x 4 ft (1.22 x 1.22 m)	320012	27.5 kg

Triangle

Product	Code	Weight
LIVEDECK 4 x 4 ft (1.22 x 1.22 m)	320008	19.5 kg
LIVEDECK Top Lock 4 x 4 ft (1.22 x 1.22 m)	320016	19.5 kg

Circle

Product	Code	Weight
LIVEDECK Quad 4 x 4 ft (1.22 x 1.22 m)	320006	27.0 kg
LIVEDECK Quad Top Lock 4 x 4 ft (1.22 x 1.22 m)	320014	13.5 kg
LIVEDECK Internal Quad 4 x 4 ft (1.22 x 1.22 m)	320007	27.0 kg
LIVEDECK Internal Quad Top Lock 4 x 4 ft (1.22 x 1.22 m)	320015	13.5 kg

WHY LIVEDECK?

- Available with or without top lock system
- No bolts screws visible from top, easy change top system
- Industry standard staging systems

 500 kg/m²
 Lateral loading 5%
 plywood 19 mm
 (RFID)
READY

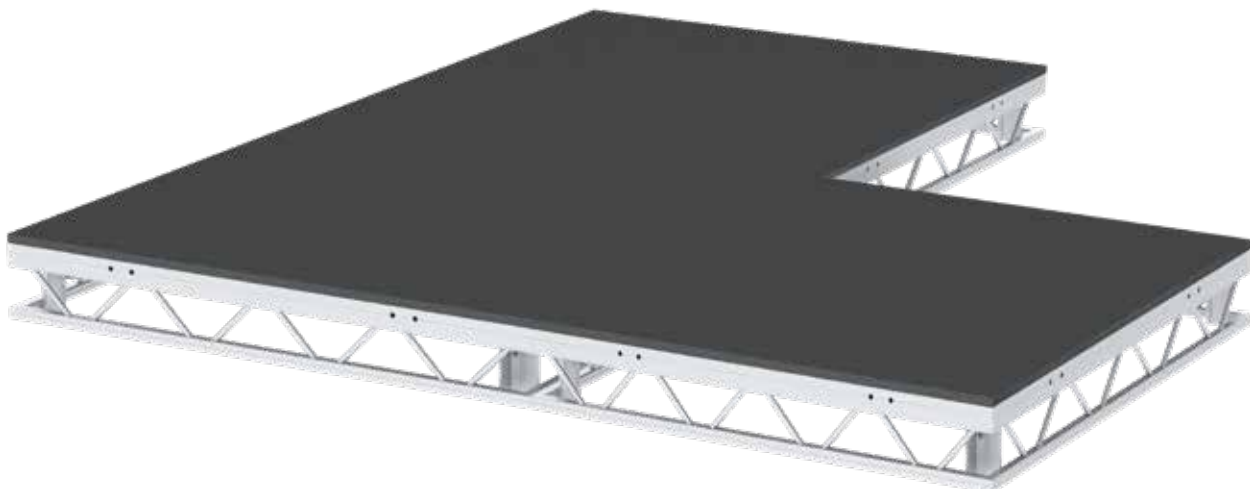



Stage Module L LIVE82

Rectangular

Product	Code
LIVE82 Deck 8 x 4 ft (2.44 x 1.22 m)	325009
LIVE82 Deck 8 x 2 ft (2.44 x 0.61 m)	325010
LIVE82 Deck 6 x 4 ft (1.83 x 1.22 m)	325011
LIVE82 Deck 4 x 2 ft (1.22 x 0.61 m)	325013

Square

Product	Code
LIVE82 Deck 4 x 4 ft (1.22 x 1.22 m)	325012

Triangle

Product	Code
LIVE82 Deck 4 x 4 ft (1.22 x 1.22 m)	325016

Circle

Product	Code
LIVE82 Deck 4 x 4 ft (1.22 x 1.22 m)	325014
LIVE82 Deck 4 x 4 ft (1.22 x 1.22 m)	325015

WHY LIVE82?

- A true second generation event staging product
- 19% less transport volume
- Completely bolted and non welded construction giving strength and accuracy
- Integrated top lock system and fast, safe rotational lock single Leg Pocket
- Compatible with existing systems
- Protected edge of wood panel and high accuracy joins
- Integrated functionality for attachment of fascias or runway lighting brackets

 500 kg/m²

 Lateral loading 5%

 plywood 19 mm

 51 kg (8 x 4 ft)

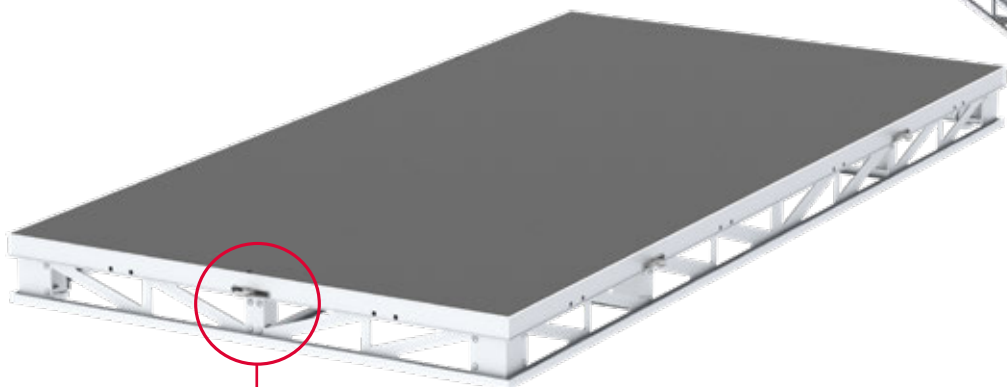

Stage Module L/M Legs



Leg Code	Length (H)
340001	20 cm
340002	40 cm
340003	60 cm
340004	80 cm
340005	100 cm

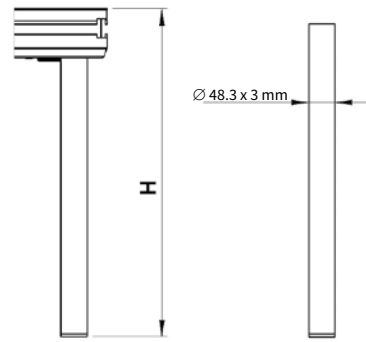

Leg with adjustable feet Code	Length (H)
340007	20 cm
340008	40 cm
340009	60 cm
340010	80 cm
340011	100 cm

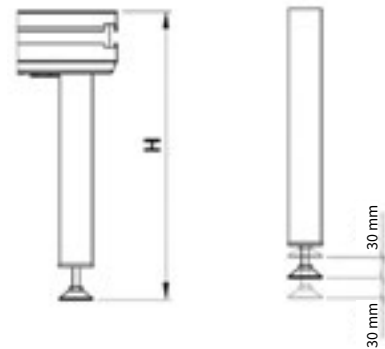

Telescopic leg Code	Length (H)
340013	45/60 cm
340014	60/90 cm
340015	90/140 cm
340016	100/160 cm
340017	120/190 cm



Leg with swivel castor - single	24.5 cm
340018	

Leg with swivel castor - double	24.5 cm
340019	



Stage Accessories

Stage-to-stage clamp

360034

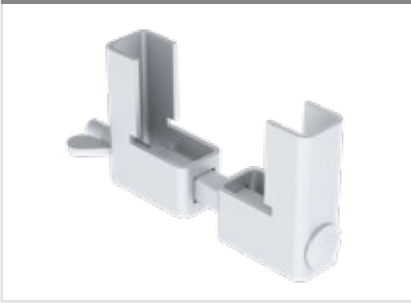

Insert M8

360006



Stage-to-stage connector

360004



Stage-to-stage leveler

360005



Leg to leg ETP Clamp 2-way

360035



Kick board - click on

Code	Length
360002	85 cm
360003	185 cm



Skirting Profile - click on

Code	Length
360009	85 cm
360010	100 cm
360011	185 cm
360012	200 cm

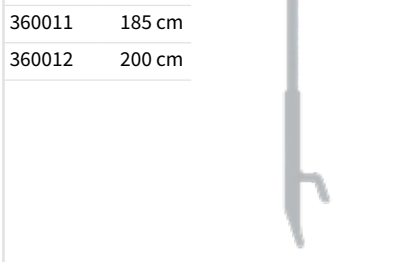



Stairs Adjustable for STAGE82 and LIVEDECK

	model 1	model 2
Height	min 40 cm / max 100 cm	min 40 cm / max 120 cm
Width overall	835 mm	835 mm
Load per step	150 kg	150 kg
Uniformly distributed load m ²	500 kg	500 kg
Weight	17.8 kg	21.6 kg
Article number	351015	351016

WHY STAIRS ADJUSTABLE?

- Fits to LIVEDECK and STAGE82
- Integrated fixation system
- Steps with anti slip surface
- Full aluminium structure
- Flush out side for ease of transport
- Low self weight



NEW

Handrail

Handrail for 4-5 step stairs

351005





Stairs Modular

NEW

Stairs Modular

Stairs Modular
351018

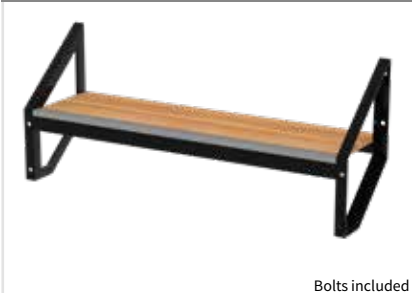

Bolts included

WHY STAIRS MODULAR?

- A single step unit, one-size fits all
- Bolted together to create stair height up to 140 cm
- Optimised packaging volume due to flat-pack-design
- Anti-slip Steps
- Loading 500 kg/m²
- Protected front edge of steps
- Integrated handrail connection



Handrail

For 3 steps Stairs Modular

351010

2 kg



For 4-5 steps Stairs Modular

351011

2.3 kg





Module M - STAGE82



Module L - LIVEDECK

Stage railing LIVEDECK	
Code	Length
350001	2 ft
350002	4 ft
350003	6 ft
350004	8 ft

Stage railing LIVEDECK vertical bars	
Code	Length
350009	2 ft
350010	4 ft
350011	6 ft
350012	8 ft



Skirting

Skirt straight finish

Polyester 160 g/m² - B1

Code	Length
360013	20 x 100 cm
360014	40 x 100 cm
360015	60 x 100 cm
360016	80 x 100 cm
360017	100 x 100 cm
360018	20 x 200 cm
360019	40 x 200 cm
360020	60 x 200 cm
360021	80 x 200 cm
360022	100 x 200 cm



Skirt pleat finish

Polyester 160 g/m² - B1

Code	Length
360023	20 x 100 cm
360024	40 x 100 cm
360025	60 x 100 cm
360026	80 x 100 cm
360027	100 x 100 cm
360028	20 x 200 cm
360029	40 x 200 cm
360030	60 x 200 cm
360031	80 x 200 cm
360032	100 x 200 cm

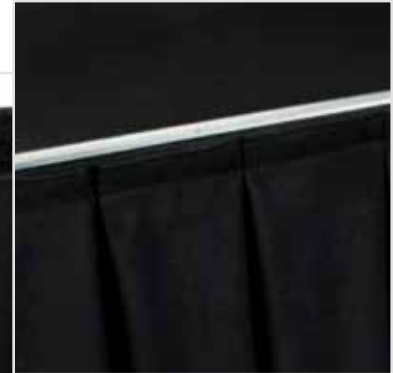

User information

Advised slinging methods

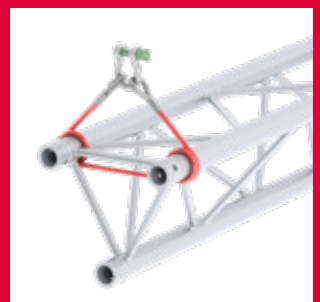
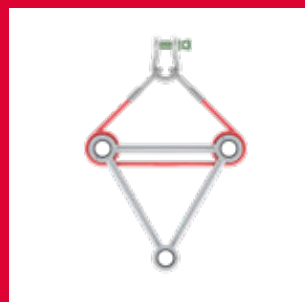
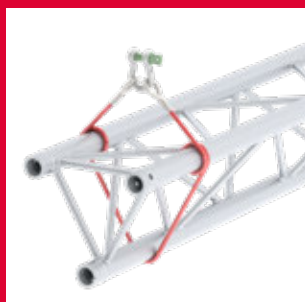
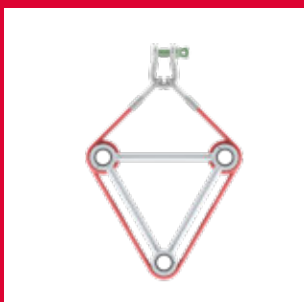
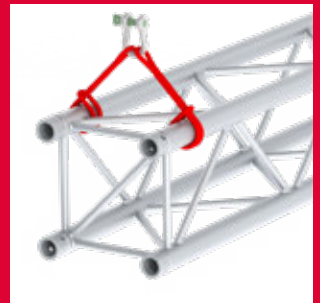
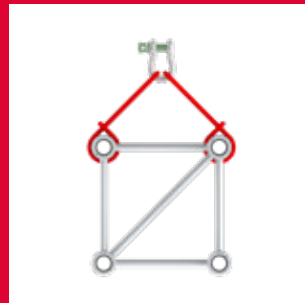
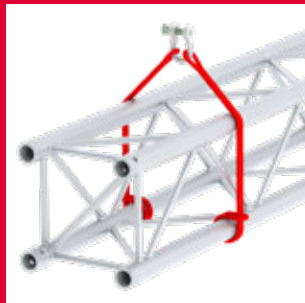
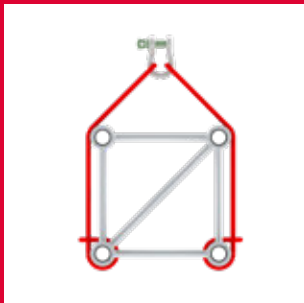

Ladder truss

These need special attention for slinging. Stabilisation of the top chord is vital for the load capacity. Only the bottom chord shall be loaded. Other load applications need structural analysis before use.

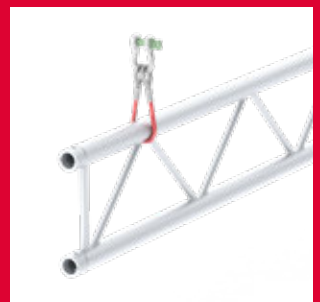

Slinging shall be applied solely at the main chords, not at the couplers or internal braces unless approved by a chartered engineer. Slinging shall be applied at node points, aside end braces or aside horizontal cross braces. Slinging equipment shall be made from non-abrasive and fire retardant materials.

For further information, please refer to the SIXTY82 original user manual.





Data Center

Type	Coupler type	Truss length	Truss wide	Material	Cross section tubes				Dead weight	RFID
					Main chord		Diagonals			
					∅ mm	≠ mm	∅ mm	≠ mm		
S22T	Model S	160.2	185.0	EN AW 6060 T6	35.0	1.5	8.0	4.0	2.5	✗
S22S		185.0	185.0		35.0	1.5	8.0	4.0	3.0	
M29L	Model M	239.0	0	EN AW 6082 T6	48.3	3.0	16.0	2.0	3.0	✓
M29T		239.0	207.0		48.3	3.0	16.0	2.0	5.0	
M29TX		239.0	207.0		51.0	2.0	16.0	2.0	4.0	
M29S		239.0	239.0		48.3	3.0	16.0	2.0	6.3	
M39T		339.0	294.0		48.3	3.0	16.0	2.0	5.5	
M39S		339.0	339.0		48.3	3.0	16.0	2.0	6.9	
M39R		339.0	339.0		48.3	3.0	16.0	2.0	6.9	
M39TOW		339.0	339.0		50.0	4.0	25.0	3.0	12.0	
L35S	Model L	299.0	299.0		50.0	4.0	30.0	3.0	12.0	✓
L35R		299.0	207.0		50.0	4.0	30.0	3.0	11.0	
L52S		470.0	470.0		50.0	4.0	30.0	3.0	15.0	
L53TOW		470.0	470.0		60.0	5.0	30.0	3.0	17.5	
XL101R		950.0	520.0		60.0	6.0	48.3	3.0	25.0	✓
XL101F		950.0	520.0		60.0	6.0	48.3	3.0	25.0	

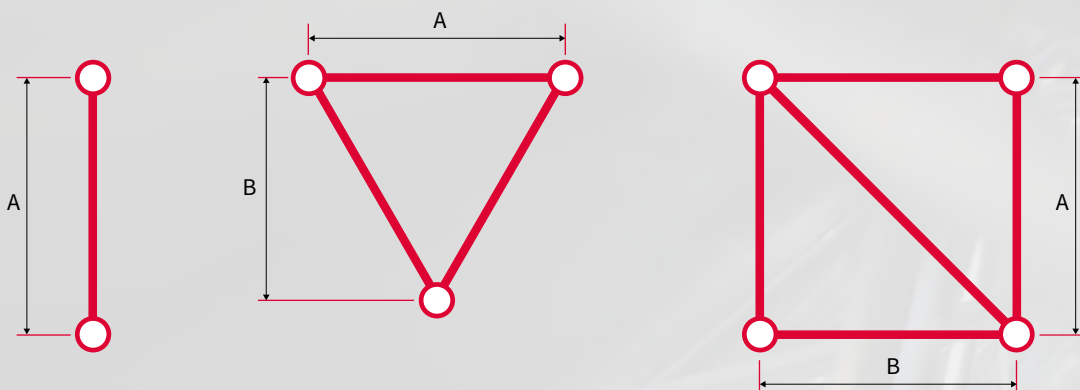

Type	Cross section truss					Permissible internal forces truss				
	A cm ²	I _y cm ⁴	I _z cm ⁴	I _y cm	I _z cm	Bending moment		Normal force	Transversal force	
						My kNm	Mz kNm	N kN	V _y kN	V _z kN
S22T	4.74	276.75	276.80	7.60	7.60	1.62	1.87	10.10	1.64	2.83
S22S	6.31	549.17	549.17	9.30	9.30	3.74	3.74	10.10	3.27	3.27
M29L	8.54	1055.16	22.0	11.12	1.61	12.08	-	101.10	-	7.36
M29T	12.81	1064.71	1064.71	9.12	9.12	10.46	12.08	151.65	7.36	12.76
M29TX	9.24	771.16	771.01	9.14	9.14	7.55	8.71	109.36	12.76	7.36
M29S	17.08	2110.33	2110.33	11.12	11.12	24.16	24.16	202.20	14.73	14.73
M39T	12.81	2119.23	2119.23	12.86	12.85	14.86	17.14	151.65	9.47	16.40
M39S	17.08	4207.89	4207.89	15.70	15.70	34.27	34.27	202.20	18.94	18.94
M39R	17.08	4207.89	2110.33	15.70	11.13	34.27	24.16	202.20	18.94	14.73
M39TOW	23.12	5698.96	5500.00	15.70	15.42	36.06	36.06	212.77	40.22	40.22
L35S	23.12	4445.05	4445.05	13.87	13.87	40.93	40.93	273.77	45.48	45.48
L35R	23.12	4445.05	1750.00	13.87	8.70	40.93	-	273.77	-	45.48
L52S	23.12	10906.19	10906.19	21.72	21.72	64.33	64.33	273.77	49.36	49.36
L53TOW	34.60	16334.00	16334.00	21.74	21.74	58.60	58.60	249.00	28.80	28.80
XL101R	40.72	78211.52	23522.57	43.83	24.04	224.32	122.79	472.26	42.54	90.48
XL101F	-	78211.52	-	43.83	-	224.32	-	472.26	-	86.61

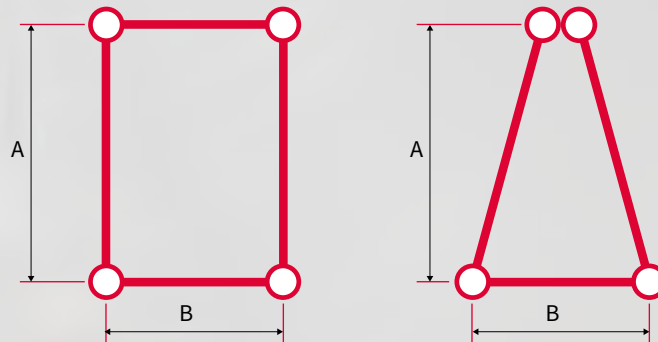

SIXTY82-FR

FR

1, allée d'Effiat
91160 Longjumeau
France

Phone: +33 (0)1 69 10 50 76
Email: SIXTY82@axente.fr

SIXTY82-UK

UK

5 Lanthwaite Road
Lanthwaite Business Park,
South Kirkby,
Wakefield,
West Yorkshire WF9 3AP
England

Phone: +44 (0) 1977 659 800
Email: uk@SIXTY82.nl

SIXTY82-NL

NL

Headquarters

Ampèrelaan 9
9207 AM Drachten
The Netherlands

Phone: +31 (0)88 13 422 00
Email: info@SIXTY82.nl



Please inform our website for the latest updates about our distribution network

United Kingdom 1

A.C. Entertainment Technologies

Leeds Office (Northern UK Sales)
Hawthornthorpe Commercial Centre,
Elder Road, Leeds, West Yorkshire,
LS13 4AT
Phone: +44 113 255 7666
E-mail: SIXTY82@ac-et.com

United Kingdom 2

A.C. Entertainment Technologies

Headoffice
Centauri House, Hillbottom Road,
High Wycombe, Buckinghamshire,
HP12 4HQ
Phone: +44 1494 446000
E-mail: SIXTY82@ac-et.com

The Netherlands 3

SENCI

Nijverheidsweg 20
7671 DA Vriezenveen
Phone: +31 85 303 65 97
E-Mail: info@senci.nl

Germany 4

Pan pro GmbH

Rudolf-Diesel-Str. 4
49393 Lohne
Phone: +49 4442 92900
E-mail: SIXTY82@pan-pro.de

Germany 5

Pan pro GmbH

Ahlbecker Str.19
10437 Berlin
Phone: +49 3034 394148
E-mail: SIXTY82@pan-pro.de

Denmark 6

European Tour Production ApS

Stamholmen 93
DK-2650 Hvidovre
Phone: +45 36 30 70 80
E-Mail: mail@etp.nu

Sweden 7

Electro Waves Oy filial Sverige

Uppköparvägen 7
12044 Årsta
Phone: +358 20 1200 100
E-mail: info@electrowaves.eu

Finland 8

Electro Waves Oy

Headoffice
Piispantilankuja 6
02240 Espoo
Phone: +358 20 1200 100
E-mail: info@electrowaves.fi

Latvia 9

JSA Europe / Stage Company

Headoffice
Valguma iela 4A - 2
Riga, LV-1048
Phone: +371 2 777 48 48
E-Mail: welcome@jsa-stage.company

Ukraine 10

JSA Europe / Stage Company

Yevhena Konovaltsia st. 103
office 414 / L'viv, 79000
Phone: +380 44 361 48 48
E-mail: welcome@jsa-stage.com

Luxembourg 11

Codex Events S.A.

36, rue d'Oetrange
L-5411 Canach
GD-Luxembourg
Phone: +352 264 83333
Email: info@codex.lu

Portugal 12

Set2Stage

Rua Gomes de Amorim nº 1158,
4490-091 - Póvoa de Varzim
Phone: +351 252 219 489
E-mail: geral@set2stage.pt



Credits

Author: Olivier FLEURETTE, Sybrèn DIJKHOFF

Catalogue design: Tieme DEKKER

With contributions from NL, FR and UK with love

PVersion: V19.1

© 2019 SIXTY82, Drachten NL

All rights reserved. No part of this publication may be reproduced in any manner without permission.

 <https://www.facebook.com/SIXTY82>

 www.SIXTY82.nl



SIXTY82™

Sixty82 BV

Ampèrelaan 9 | 9207 AM Drachten | The Netherlands

+31 88 13 422 00

info@sixty82.nl

www.sixty82.nl

The New Original