

**PHILIPS**  
**Selecon**

**PLFRESNEL1 MKII**  
**LED Luminaire**



*For PLFR1MKII-03*

## Philips Selecon Offices

### Philips Selecon - Dallas

10911 Petal Street  
Dallas, TX 75238  
Tel: +1 214-647-7880  
Fax: +1 214-647-8030

### Philips Selecon - Auckland

19-21 Kawana Street  
Northcote, Auckland 0627  
New Zealand  
Tel: +64 9 481 0100  
Fax: +64 9 481 0101

### Philips Selecon - Asia Limited

Unit C, 14/F, Roxy Industrial Centre  
No. 41-49 Kwai Cheong Road  
Kwai Chung, N.T., Hong Kong  
Tel: +852 2796 9786  
Fax: +852 2798 6545

### Philips Selecon - Europe

Rondweg zuid 85  
Winterswijk 7102 JD  
The Netherlands  
Tel: +31 (0) 543-542516

### Website:

[www.seleconlight.com](http://www.seleconlight.com)

The material in this manual is for information purposes only and is subject to change without notice. Philips Selecon assumes no responsibility for any errors or omissions which may appear in this manual. For comments and suggestions regarding corrections and/or updates to this manual, please visit the Philips Selecon web site at [www.seleconlight.com](http://www.seleconlight.com) or contact your nearest Philips Selecon office.

El contenido de este manual es solamente para información y está sujeto a cambios sin previo aviso. Philips Selecon no asume responsabilidad por errores o omisiones que puedan aparecer. Cualquier comentario, sugerencia o corrección con respecto a este manual, favor de dirijirlo a la oficina de Philips Selecon más cercana.

Der Inhalt dieses Handbuchs ist nur für Informationszwecke gedacht, Aenderungen sind vorbehalten. Philips Selecon uebernimmt keine Verantwortung für Fehler oder Irrtuemer, die in diesem Handbuch auftreten. Für Bemerkungen und Verbesserungsvorschlaege oder Vorschlaege in Bezug auf Korrekturen und/oder Aktualisierungen in diesem Handbuch, moechten wir Sie bitten, Kontakt mit der naechsten Philips Selecon-Niederlassung aufzunehmen.

Le matériel décrit dans ce manuel est pour information seulement et est sujet à changements sans préavis. La compagnie Philips Selecon n'assume aucune responsabilité sur toute erreur ou ommission inscrite dans ce manuel. Pour tous commentaires ou suggestions concernant des corrections et/ou les mises à jour de ce manuel, veuillez s'il vous plait contacter le bureau de Philips Selecon le plus proche.

---

**Note:** Information contained in this document may not be duplicated in full or in part by any person without prior written approval of Philips Selecon. Its sole purpose is to provide the user with conceptual information on the equipment mentioned. The use of this document for all other purposes is specifically prohibited.

---

Document Number: **02.9701.2001**

Version as of: **01 September 2015**

PLFRESNEL1 MKII LED Luminaire Installation & User's Manual

©2015 Philips Group. All rights reserved.

# IMPORTANT INFORMATION

## Warnings and Notices

When using electrical equipment, basic safety precautions should always be followed including the following:



- a. **READ AND FOLLOW ALL SAFETY INSTRUCTIONS.**
- b. Do not use outdoors.
- c. Do not mount near gas or electric heaters.
- d. Equipment should be mounted in locations and at heights where it will not readily be subjected to tampering by unauthorized personnel.
- e. The use of accessory equipment not recommended by the manufacturer may cause an unsafe condition.
- f. Do not use this equipment for other than intended use. This equipment is not for residential installation or use.
- g. Refer service to qualified personnel.

**SAVE THESE INSTRUCTIONS.**



**WARNING:** You must have access to a main circuit breaker or other power disconnect device before installing any wiring. Be sure that power is disconnected by removing fuses or turning the main circuit breaker off before installation. Installing the device with power on may expose you to dangerous voltages and damage the device. A qualified electrician must perform this installation.

**WARNING:** Refer to National Electrical Code® and local codes for cable specifications. Failure to use proper cable can result in damage to equipment or danger to personnel.

**WARNING:** This equipment is intended for installation in accordance with the National Electric Code® and local regulations. It is also intended for installation in indoor applications only. Before any electrical work is performed, disconnect power at the circuit breaker or remove the fuse to avoid shock or damage to the control. It is recommended that a qualified electrician perform this installation.

## Additional Resources for DMX512

For more information on installing DMX512 control systems, the following publication is available for purchase from the United States Institute for Theatre Technology (USITT), "Recommended Practice for DMX512: A Guide for Users and Installers, 2nd edition" (ISBN: 9780955703522). USITT Contact Information:

**USITT**  
**315 South Crouse Avenue, Suite 200**  
**Syracuse, NY 13210-1844**  
**Phone: 1.800.938.7488 or 1.315.463.6463**  
**[www.usitt.org](http://www.usitt.org)**

## Philips Selecon Limited Three-Year Warranty

Philips Selecon offers a three-year limited warranty of its luminaires against defects in materials or workmanship from the date of delivery. A copy of the Philips Selecon three-year limited warranty containing specific terms and conditions can be obtained from the Philips Selecon web site at [www.seleconlight.com](http://www.seleconlight.com) or by contacting your local Philips Selecon office. PLFRESNEL1 MKII LED Luminaire powerful LED engine offers exceptional performance and life. Under normal operating conditions, our LED engine has a life expectancy in excess of 50,000 hours, however under worst case operating conditions with the luminaire set to continuous full output it is possible that a small percentage of LED's may require replacement sooner. The Philips Selecon three-year limited warranty includes our guarantee against premature failure of the LED engine.

# TABLE OF CONTENTS

|   |                    |
|---|--------------------|
| Philips Selecon Offices.....                                    | Inside Front Cover |
| <b>IMPORTANT INFORMATION</b>                                    |                    |
| Warnings and Notices.....                                       | 1                  |
| Additional Resources for DMX512.....                            | 1                  |
| Philips Selecon Limited Three-Year Warranty.....                | 1                  |
| <b>TABLE OF CONTENTS</b>  |                    |
| <b>PREFACE</b>  |                    |
| About this Manual.....  | 4                  |
| Accessories.....  | 4                  |
| PLFRESNEL1 MKII LED Luminaire Power Input Cables.....           | 4                  |
| PLFRESNEL1 MKII LED Luminaire Lens Accessories.....             | 4                  |
| PLFRESNEL1 MKII LED Luminaire Clamps.....                       | 4                  |
| PLFRESNEL1 MKII LED Luminaire USB Luminaire Software Cable..... | 4                  |
| PLFRESNEL1 MKII LED Luminaire Top Box Assembly.....             | 4                  |
| <b>PLFRESNEL1 MKII LED LUMINAIRE OVERVIEW</b>                   |                    |
| PLFRESNEL1 MKII LED Luminaire Components.....                   | 5                  |
| Major Luminaire Components.....                                 | 5                  |
| Top Box (PLICB) Luminaire Connections.....                      | 6                  |
| LCD Display / Menu System.....                                  | 6                  |
| <b>INSTALLATION AND SET UP</b>                                  |                    |
| Power Requirements.....   | 7                  |
| Connecting Power.....   | 7                  |
| Connecting to the DMX512 Network.....                           | 8                  |
| Mounting.....   | 9                  |
| Using Supplied C-Clamp.....                                     | 9                  |
| Safety Cable Use.....   | 9                  |
| Pan and Tilt Adjustments.....                                   | 10                 |
| Pan Adjustment.....   | 10                 |
| Tilt Adjustment.....  | 10                 |
| <b>BEAM ADJUSTMENTS</b>   |                    |
| Beam Adjustments.....   | 11                 |
| Barndoor Assembly.....  | 11                 |
| <b>OPERATION AND PROGRAMMING</b>                                |                    |
| LCD Menu Operation.....   | 12                 |
| LCD Menu System.....  | 13                 |
| Menu Structure.....   | 14                 |
| Security.....   | 16                 |
| Locking Fixture.....  | 16                 |
| Presets.....  | 17                 |
| Editing Preset Names.....                                       | 17                 |
| Settings.....   | 17                 |
| <b>DMX CONTROL</b>  |                    |
| 16-Bit Mode.....  | 19                 |
| 8-Bit Mode.....   | 21                 |
| DMX 5-Channel (5-Chan) Mode.....                                | 23                 |

PLFRESNEL1 MKII LED Luminaire DMX Timing Channel Detail ..... 23

**CLEANING AND CARE**

Special Cleaning and Care Instructions..... 29

Service and Maintenance..... 29

Accessories ..... 29

**TROUBLESHOOTING**

Troubleshooting Guide ..... 30

**TECHNICAL SPECIFICATIONS**

PLFRESNEL1 MKII LED Luminaire Operational Specifications ..... 31

PLFRESNEL1 MKII LED Luminaire Dimensions ..... 31

# PREFACE

## 1. About this Manual

The document provides installation and operation instructions for the following products:

- PLFRESNEL1 MKII LED Luminaire (PLFR1MKII-03).

Please read all instructions before installing or using this product. *Retain this manual for future reference.* Additional product information and descriptions may be downloaded at [www.seleconlight.com](http://www.seleconlight.com)

**Note:** All PLFRESNEL1 MKII LED Luminaires are universal voltage (100VAC to 240VAC, Auto-ranging).

## 2. Accessories

Contact your Authorized Philips Selecon Dealer for price and availability of all accessories for PLFRESNEL1 MKII LED Luminaires. Additional information can be found on the Philips Selecon web site at [www.seleconlight.com](http://www.seleconlight.com).

### PLFRESNEL1 MKII LED Luminaire Power Input Cables

| Part Number | Description  |
|-------------|--|
| PC1BE       | PLFRESNEL1 MKII LED Luminaire AC Power Input Cable (39 inches / 1 meter), Powercon without Connector (user to supply AC connector) |
| PC1GP       | PLFRESNEL1 MKII LED Luminaire AC Power Input Cable (39 inches / 1 meter), Powercon with Stagepin Connector                         |
| PC1GTL      | PLFRESNEL1 MKII LED Luminaire AC Power Input Cable (39 inches / 1 meter), Powercon with Twistlock Connector                        |
| PC1GR       | PLFRESNEL1 MKII LED Luminaire AC Power Input Cable (39 inches / 1 meter), Powercon with Edison Connector                           |
| PC3PC       | PLFRESNEL1 MKII LED Luminaire PowerCon Male to PowerCon Female 2.5 Meter Cable for interconnection between units                   |

### PLFRESNEL1 MKII LED Luminaire Lens Accessories

| Part Number | Description                            |
|-------------|--|
| 20BDMF      | Acclaim Fresnel Barndoor, 4 Way, Black |

### PLFRESNEL1 MKII LED Luminaire Clamps

| Part Number | Description                       |
|-------------|-----------------------------------|
| SC          | Selecon Molded Yoke rated C-Clamp |
| MC          | Mega Claw, Black Anodized         |

### PLFRESNEL1 MKII LED Luminaire USB Luminaire Software Cable

| Part Number | Description   |
|-------------|---|
| PEGASUS     | USB Luminaire Software Programming Kit (for updating luminaire firmware) - includes USB Upload Cable, QuickStart Guide, and Carry Bag |

### PLFRESNEL1 MKII LED Luminaire Top Box Assembly

| Part Number | Description                           |
|-------------|---------------------------------------|
| PLICB       | Spare Top Box (Interconnect) Assembly |

# PLFRESNEL1 MKII LED LUMINAIRE OVERVIEW

## 1. PLFRESNEL1 MKII LED Luminaire Components

### Major Luminaire Components

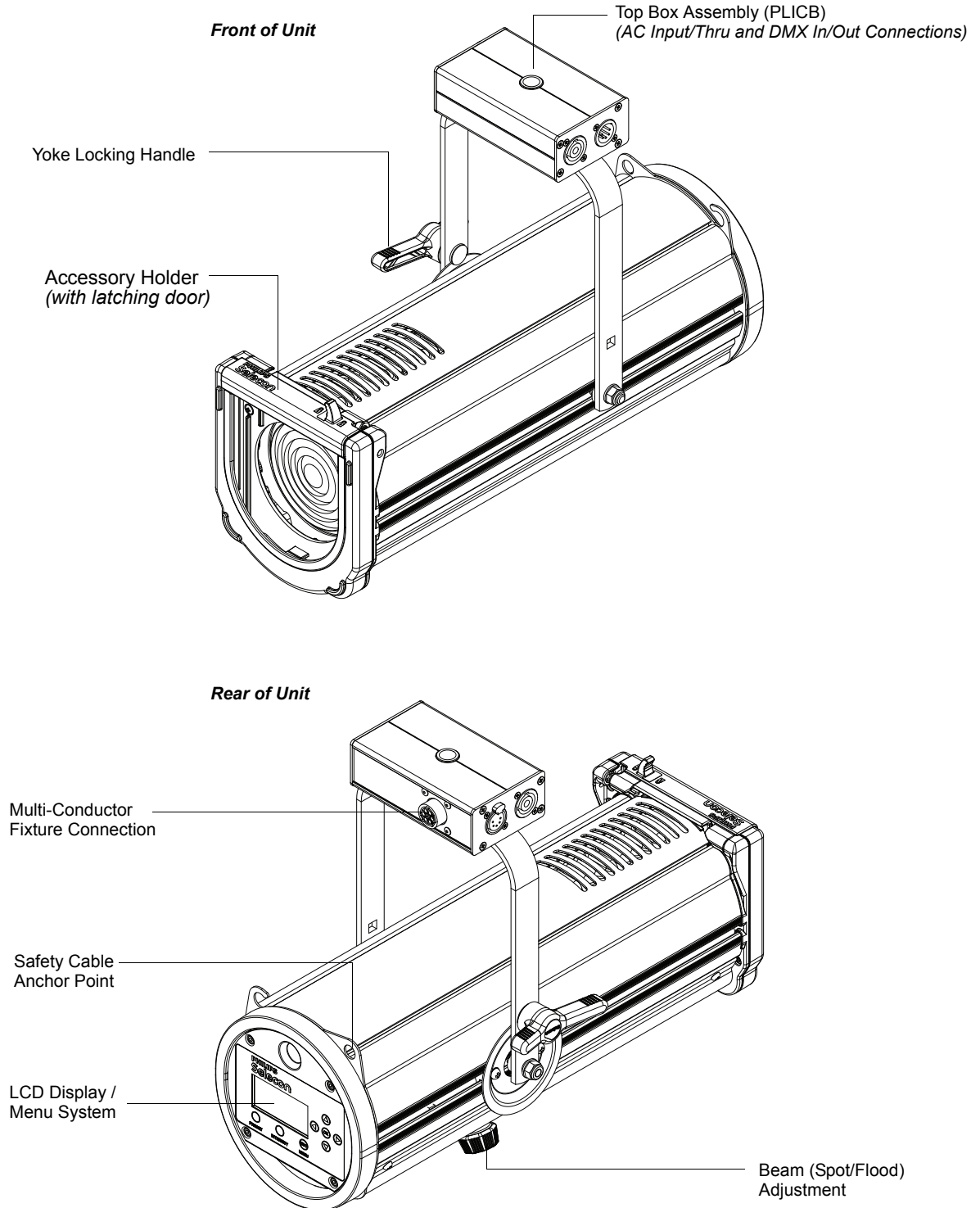

For the LCD Display Menu System, refer to "LCD Display / Menu System" on page 6 for more information.

Figure 1: PLFRESNEL1 MKII LED Luminaire Components

### Top Box (PLICB) Luminaire Connections

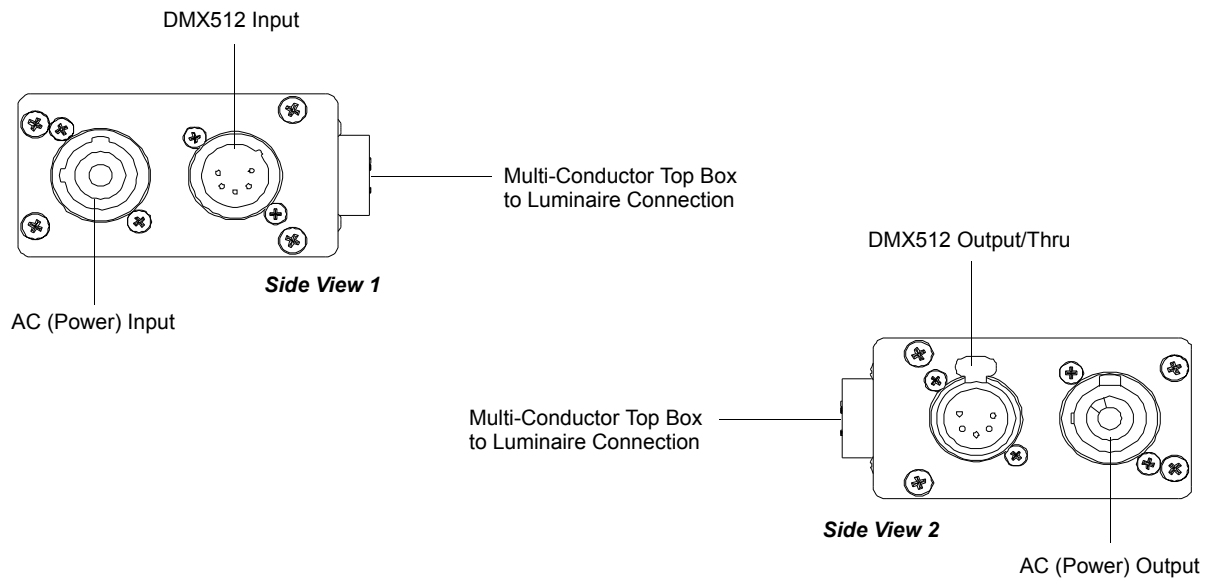
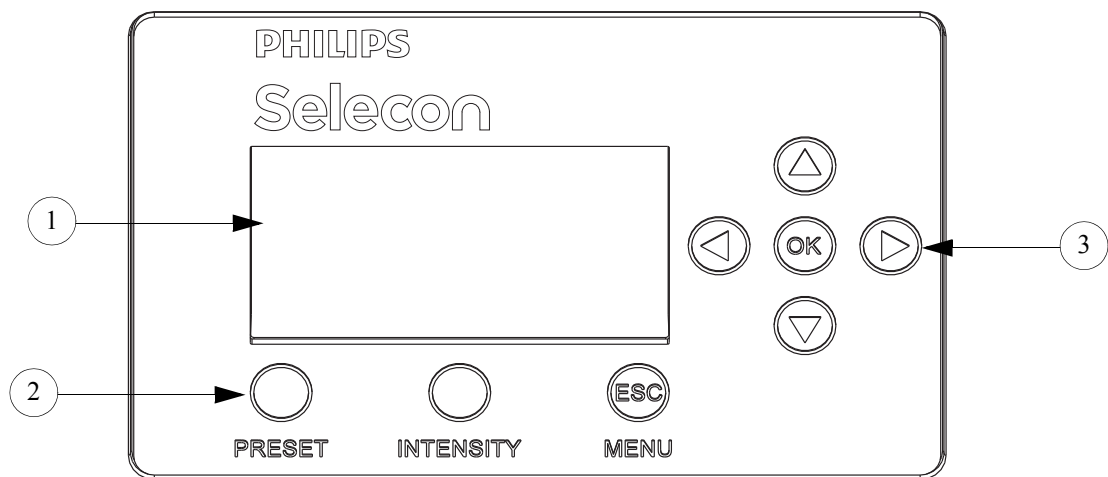

Figure 2: Top Box (PLICB) Connections

### LCD Display / Menu System



- 1) LCD Display (Menu System)
- 2) Preset / Intensity / Menu Access Buttons
- 3) Function (Menu System) Select Push Buttons

**Note:** For Menu operation and programming details, refer to "[LCD Menu Operation](#)" on page 12.

Figure 3: PLFRESNEL1 MKII LED Luminaire LCD Display & Menu System



# INSTALLATION AND SET UP

## 1. Power Requirements



**WARNING!** The PLFRESNEL1 MKII LED Luminaire should be connected to a constant circuit or a relay device. It should never be connected to a dimmer or circuit controlled by a dimmer.

The PLFRESNEL1 MKII LED Luminaire operates on 100 to 240 volts AC (+/- 10%, auto-ranging). The luminaire contains an auto-ranging power supply. Depending on supply voltage, each luminaire can draw up to 140 Watts. The maximum through current should not exceed 20 Amps\*.



**WARNING!** \*The Maximum Allowable Input Current of 20 Amps (and the maximum power supply limit of 140 Watts). *Do not overload circuits! Must be supplied by a branch circuit protected by a maximum 20 Amp circuit protector. Doit être alimenté par un circuit de dérivation protégé par un maximum de 20 ampères circuit protecteur. Do not overload circuits!*



**IMPORTANT AC POWER CONNECTION NOTES:**



- a. *Must be supplied by a branch circuit protected by a maximum 20 Amp circuit protector. Doit être alimenté par un circuit de dérivation protégé par un maximum de 20 ampères circuit protecteur.*
- b. When using the daisy-chain connection method, ONLY connect PLFRESNEL1 MKII LED Luminaires to AC Output Connection of PLFRESNEL1 MKII LED Luminaires. DO NOT CONNECT OTHER TYPES OF LUMINAIRES OR DEVICES!
- c. Use only use approved cable types.
- d. Do not overload circuits!
- e. Do not connect PLFRESNEL1 MKII LED Luminaires to dimmed circuits.
- f. The MAXIMUM allowable number of PLFRESNEL1 MKII LED Luminaires which can be 'daisy-chained' on one power feed should not exceed ratings. DO NOT EXCEED!

## 2. Connecting Power

Units can be powered in one of two ways:

- Direct connection to a AC power source using an AC input cable.
- Daisy chain connection using a interconnect AC cable.

If the unit is supplied with an AC input cable but you did not order an AC input connector, [Table 1 on page 8](#) describes how to connect power to your PLFRESNEL1 MKII LED Luminaire. Field wiring of the PLFRESNEL1 MKII LED Luminaire is straight forward. A total of 3 wires/conductors need to be brought to the unit. The following wiring scheme is required:

**Table 1: PLFRESNEL1 MKII LED Luminaire AC Input Connections**

| Wire Color   | Purpose                     |
|--------------|-----------------------------|
| Brown        | Main / Line (120 to 240VAC) |
| Blue         | Neutral                     |
| Green/Yellow | Ground                      |

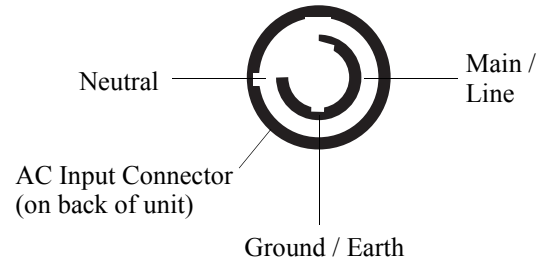

### 3. Connecting to the DMX512 Network

Basic DMX512 installation consists of connecting multiple PLFRESNEL1 MKII LED Luminaires together (up to 30 luminaires) in "daisy-chain" fashion. A cable runs from the control console (or DMX512 control source) to the DMX connector on the first PLFRESNEL1 MKII LED Luminaire. Another cable runs from the other DMX connector on the first unit to a DMX connector on the next PLFRESNEL1 MKII LED Luminaire (or DMX512 device to be controlled).

**Note:** For more information on DMX512 networking and systems, refer to ["Additional Resources for DMX512"](#) on page 1. For PLFRESNEL1 MKII LED Luminaire DMX Mapping, refer to ["DMX CONTROL"](#) on page 19.

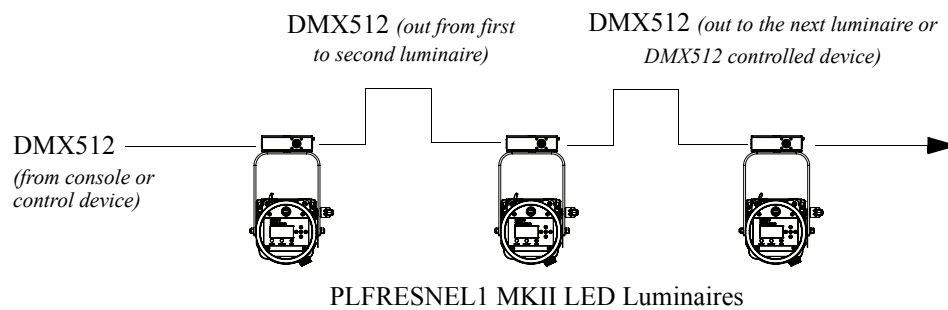

| DMX512 Connections               |                                   |                          |                          |                          |                          |                                |
|----------------------------------|-----------------------------------|--------------------------|--------------------------|--------------------------|--------------------------|--------------------------------|
| <b>Data Thru</b><br>Cable Pinout | <b>Pin 1</b><br>Common<br>(Drain) | <b>Pin 2</b><br>Data (-) | <b>Pin 3</b><br>Data (+) | <b>Pin 4</b><br>Not Used | <b>Pin 5</b><br>Not Used | <b>Data In</b><br>Cable Pinout |
| <p>Male Conn</p>                 |                                   |                          |                          |                          |                          | <p>Female Conn</p>             |

**Figure 4: PLFRESNEL1 MKII LED Luminaires - DMX512 Connections**

## 4. Mounting



**WARNING!** Before attempting any installation or service, disconnect all power at power source. Dimming the luminaire does not disconnect power. Installation and service should only be performed by a trained and qualified professional.

### Using Supplied C-Clamp

As illustrated in **Figure 5**, at yoke assembly, thread clamp mounting bolt (with washer installed) through center clamp mounting hole at top of yoke, through Top Box Assembly, and thread bolt into C-Clamp. Securely tighten bolt (by hand) into clamp (but do not overtighten).

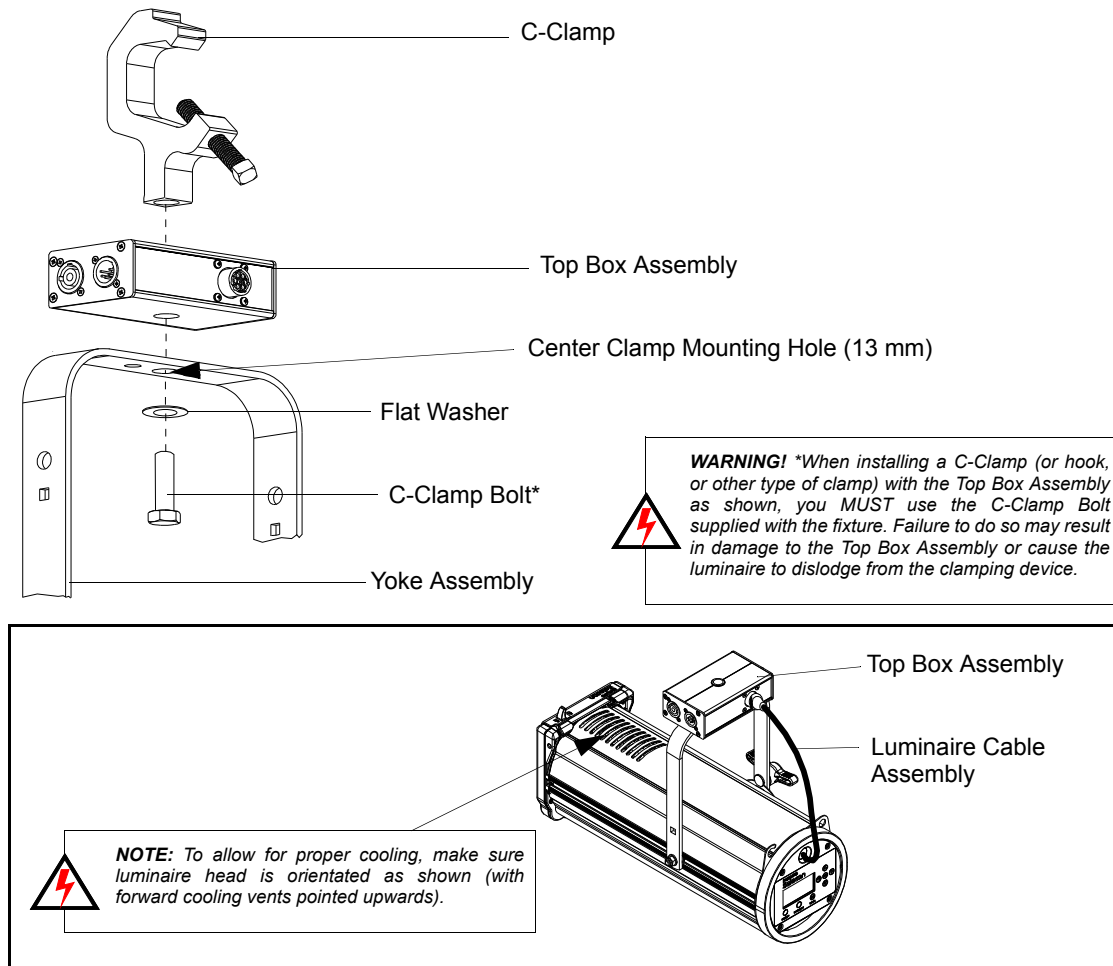

**Figure 5: Luminaire Mounting**

To mount on a telescopic stand, reverse the yoke under the luminaire and bolt to stand. Please note luminaire orientation (see note in **Figure 5**) for proper cooling.

**Note:** After installing Clamp and Top Box assembly, connect luminaire cable assembly to Top Box Assembly before mounting luminaire. Please note that the cable connector is keyed.

### Safety Cable Use

The supplied safety cable **MUST** always be used when rigging luminaires on bars, truss, etc. (as shown in **Figure 6**). The supplied safety cable is recommended for all hanging installation and may be required by national and local

codes. Loop or attach safety cable to luminaire safety cable anchor point as shown and attach to structure. You should always consult and follow all local and national codes and regulations for mounting and installation of luminaire.

## 5. Pan and Tilt Adjustments

### Pan Adjustment

The pan adjustment of a PLFRESNEL1 MKII LED Luminaire is achieved by loosening the yoke bolt of the securing clamp attached to the luminaire's yoke assembly. Loosen the bolt, set the luminaire to the desired position and retighten.

### Tilt Adjustment

PLFRESNEL1 MKII LED Luminaires offer variable tilt settings. The unit can be set at a specific angle (in relation to its mounting position) or at an angle between 0 to 90 degrees. When the yoke is in the position shown in **Figure 6**, you have full range access to shutters the gate etc. If you flip the yoke over some access is reduced but the over all volume the luminaire takes up is reduced. This is particularly useful in tightly hung lighting positions or in theatres with low grids.

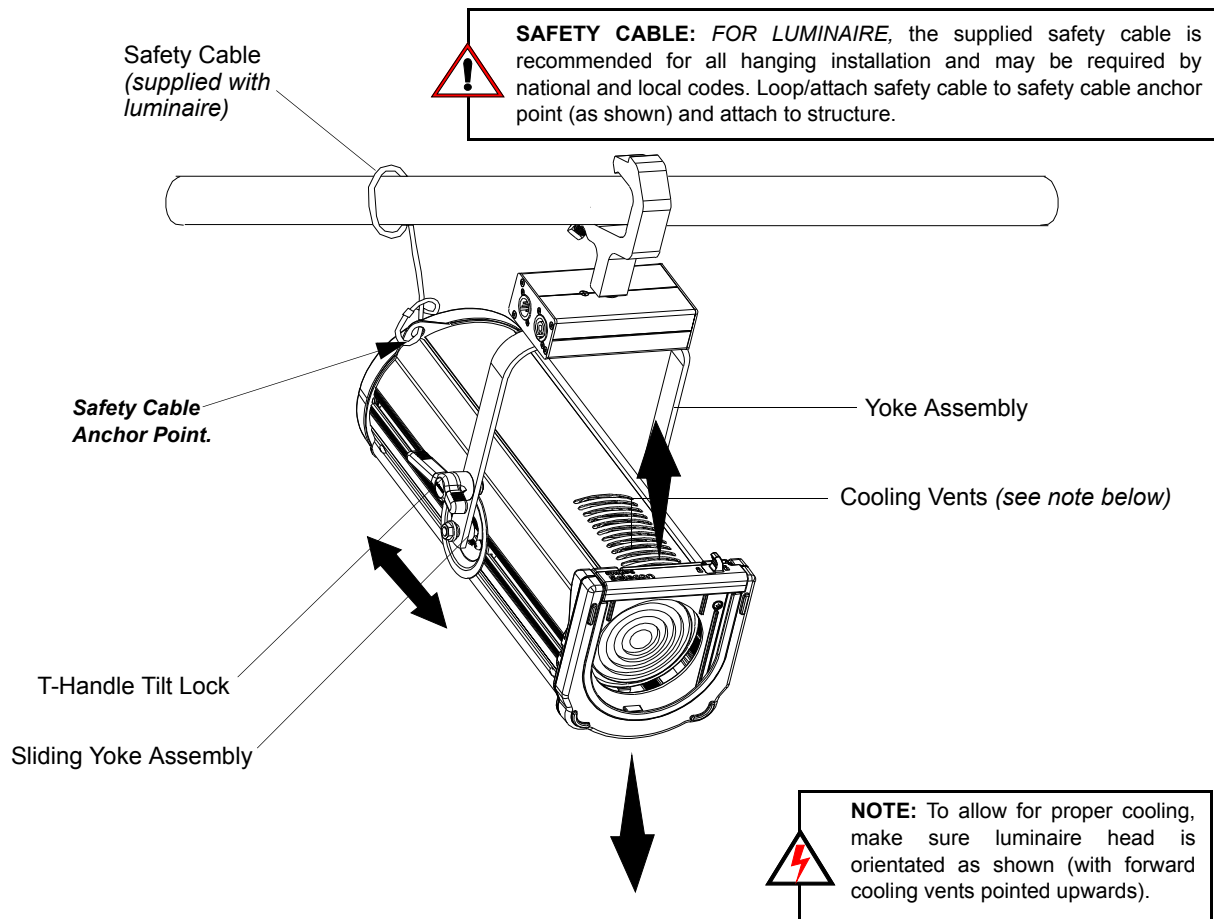

**Figure 6: Luminaire Tilt Adjustment**

#### To adjust and set tilt angle of the luminaire:

- Step 1. Mount luminaire in desired location (see "[Mounting](#)" on page 9 for more information).
- Step 2. Loosen, but do not remove, T-Handle Tilt Lock at base of yoke assembly as shown in **Figure 6**.
- Step 3. Position luminaire to desired tilt position.
- Step 4. Retighten T-Handle Tilt Lock to set position.

# BEAM ADJUSTMENTS

## 1. Beam Adjustments

To adjust the beam on the :

- Step 1. As shown in **Figure 7**, loosen Beam Adjustment Knob
- Step 2. Slide beam adjustment back (for spot) or forward (for flood) as desired.
- Step 3. Hand-tighten Beam Adjustment Knob to lock position.

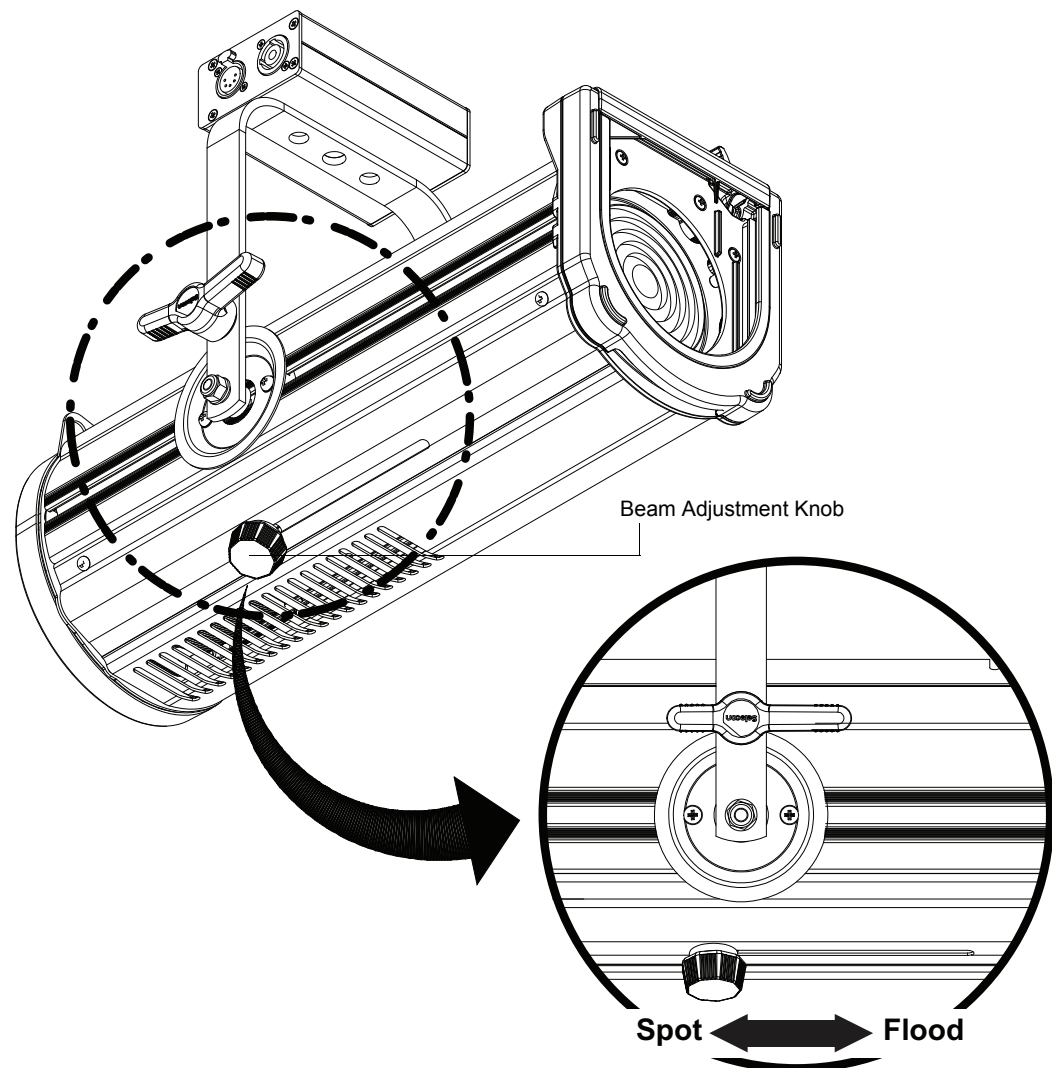

Figure 7: Zoom and Focus Adjustment Knobs

## 2. Barndoor Assembly

Philips Selecon offers as an optional accessory, a four-leaf barndoor assembly. This assembly is sold separately and available from your Authorized Philips Selecon Authorized Dealer. For information on all available accessories for the PLFRESNEL1 MKII LED Luminaire, refer to ["Accessories" on page 4](#).

# OPERATION AND PROGRAMMING

## 1. LCD Menu Operation

The PLFRESNEL1 MKII LED Luminaire's LCD Display and Menu System provides local control for accessing all the fixture's status information, menu options, and settings.

**Note:** If there are multiple luminaires in a system, changes would need to be made at each LCD Menu as desired.

Upon power up, the LCD will display the main screen showing the product type/name. If DMX is enabled, the programmed address will appear after power up.

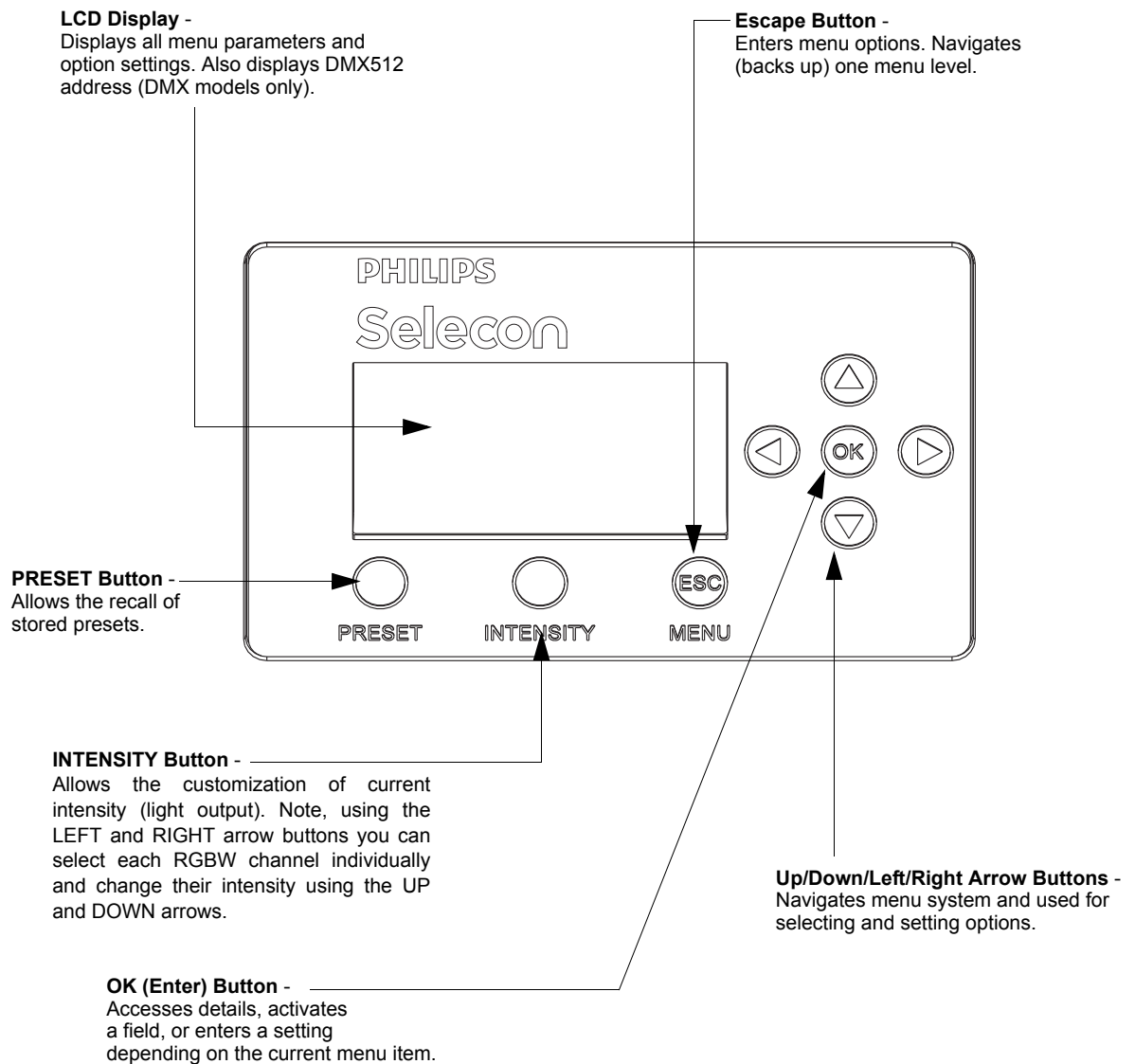

Figure 8: LCD Display and Menu System

## 2. LCD Menu System

The LCD Display Menu system consists of several categories. Use the four arrow buttons as required (refer to **Figure 8 on page 12**) to access and make changes to the menu items. When the desired menu item is reached, press [OK] to display the menu options. Use navigation and [OK] buttons to view status and configure the LCD Menu as required.

---

**Note:** Refer to "Menu Structure" on page 14 for complete structure and settings.

---

### To navigate and access menu settings/selections:

Step 1. At Main Menu, press [ESC] / [MENU] button once. Another window will appear with sub-menu categories:

- Save as Preset
- Edit a Preset
- Color Mixer
- Settings
- Lock Fixture
- Fixture Status
- Normalize Colors

Step 2. Press [OK] at desired menu item to access and make changes.

Step 3. Make changes as desired.

---

**Note:** When DMX512 signal is present, **Edit Preset** and **Color Mixer** options will not appear in menu structure.

---

### To navigate fixture status menus:

Step 1. At default screen, press LEFT or RIGHT arrow button once. The default menu screen will change to allow for quick reference to the following items (note, depending on which arrow button is pressed, status screens may appear in reverse order):

- a. **DMX Address** (note, if fixture is UNLOCKED, hit [OK] to change DMX address).
- b. **Fixture Hours** (displays fixture operating hours since last reset).
- c. **Fixture Power** (displays Max Power Limit setting (in Watts), Present Power consumed by fixture (in Watts), and Hours of Use).
- d. **Fixture Status** (displays current operational temperature, LED status, and fan speed setting).

Step 2. Press LEFT or RIGHT arrow buttons to scroll through status screens.

Step 3. Press [ESC] at anytime to access Main Menu.

### 3. Menu Structure

**Note:** See "To navigate and access menu settings/selections:" on page 13 to learn how to access menus. To save changes, hit [OK]. Press [ESC] to cancel any changes you made.

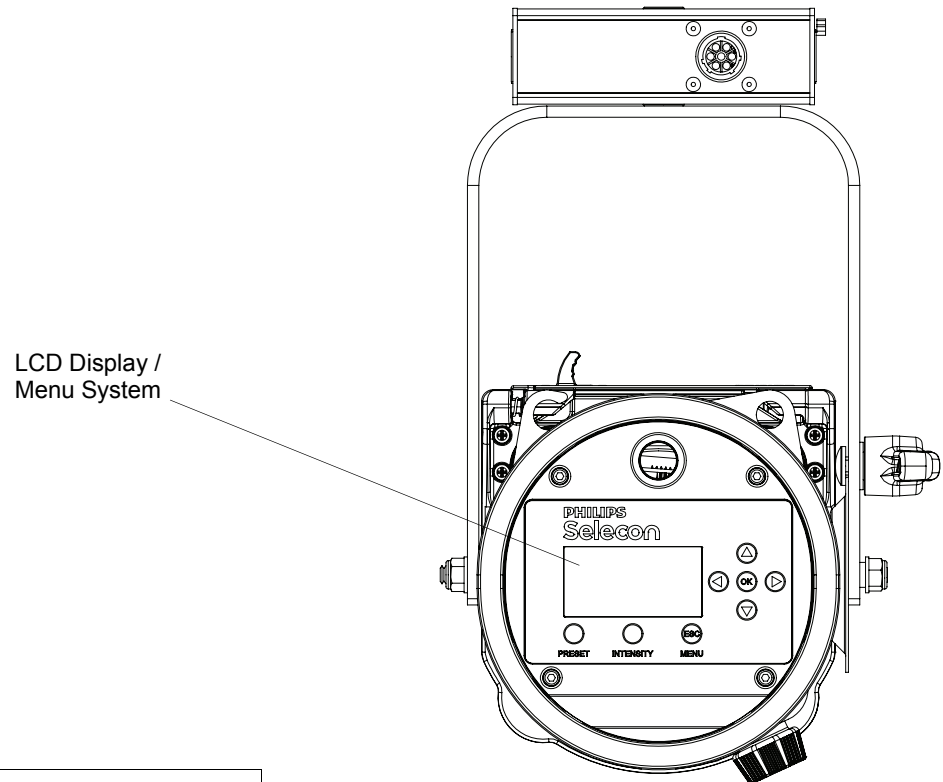

#### MAIN MENU

##### Save a Preset

| Sub Menu   | Options                 | Comments  |
|--|-------------------------|---|
| Select Preset to Save - (Option)<br><br><i>Scrolls and sets current user-defined color mix to various recallable presets in the fixture using arrow buttons.</i><br><br><i>Note: To edit a current (set) preset, see Edit Presets.</i> | Off                     | Users can: <ul style="list-style-type: none"> <li>Save the current settings (look) to a specific recallable Preset in the fixture's memory.</li> <li>Edit the levels (values) for Red, Green, Blue, White, and Intensity values (in percent%) by using the arrow buttons. Once the values are adjusted, the preset is saved as desired.</li> </ul> *Only intensities may be stored on White Color Temperature presets. RGBW in these presets cannot be edited or changed. |
|  | Scratch Pad             |   |
|  | Warm White*             |   |
|  | Cool White*             |   |
|  | Day Light*              |   |
|  | Preset X (5 through 31) |   |

Continued next page



## Menu Structure (continued)

Continued from previous page

### Edit a Preset

| Sub Menu   | Options                   | Comments   |
|--|---------------------------|--|
| Select Preset to Edit - (Option)<br>Selects a current preset and outputs the preset, so preset can be edited.<br>Note: To save a specific look of the fixture, see Save Presets.<br>For additional information, refer to "Presets" on page 17. | Off                       | Users can: <ul style="list-style-type: none"> <li>Edit the current settings (look) to a specific recallable Preset in the fixture's memory.</li> <li>Edit the values for Red, Green, Blue, White, and Intensity values (in percent%) by using the arrow buttons.</li> <li>Once the values are adjusted, the "Save Preset" menu option appears to save the edits.</li> </ul> NOTES:<br>*Only intensities may be stored on White Color Temperature presets. RGBW in these presets cannot be edited or changed.<br>**If a Calibrated Preset's Color Mix is changed (5 thru 25), an asterisk "*" is appended to the end of the name to indicate that it has been modified. This only happens if the name matches the original calibrated name, stored in EEPROM. This does not happen if the Intensity is changed, only the color mix. |
|  | Scratch Pad               |  |
|  | Warm White*               |  |
|  | Cool White*               |  |
|  | Day Light*                |  |
|  | Preset X (5 through 31)** |  |
| Note: When DMX512 signal is present, Edit a Preset option will not appear in menu structure.   |                           |  |

### Color Mixer

| Sub Menu   | Options   | Comments  |
|--|-----------|---|
| Select Color or Intensity to Adjust - (Option)   | Red       | Users can: <ul style="list-style-type: none"> <li>Edit Red, Green, Blue, White, and Intensity values (in percent%) by using the arrow buttons.</li> <li>Once the values are adjusted, press [OK] to save the edits to scratch pad.</li> </ul> |
|  | Green     |   |
|  | Blue      |   |
|  | White     |   |
|  | Intensity |   |
| Note: When DMX512 signal is present, Color Mix option will not appear in menu structure. |           |   |

### Settings

| Sub Menu  | Options                                | Comments |
|---|--|----------|
| SETTINGS - (Option)<br>Scrolls and sets the various fixture settings using arrow buttons. | See "Settings" on page 17 for details. |          |

Continued next page

## Menu Structure (continued)

Continued from previous page

| <b>Lock Fixture</b>  |                                |   |
|--|--------------------------------|---|
| <i>Sub Menu</i>  | <i>Options</i>                 | <i>Comments</i>   |
| Enter PIN  | Lock / Are you sure?           | Use arrow buttons to make selection. Press [OK] to accept. Note, a PIN code must be established (set) in order to lock a fixture. Locking the fixture will disable access to changing menu settings. For details, refer to "Security" on page 16. |
| <b>Fixture Status</b>  |                                |   |
| <i>Sub Menu</i>  | <i>Options</i>                 | <i>Comments</i>   |
| LED Status Information<br><br><i>Scrolls through the various levels. Depending on the arrow button pressed, the screens may appear in a different order that shown in "Options".</i> | LED 1                          | Displays LED's current status (in percentage%) of Intensity, Red, Green, Blue, and White elements of the LED). Fan Speed, operational LED junction temperature, power settings.   |
|  | Levels                         | Displays DMX levels for each LED element (Red, Green, Blue, and White) and total power.   |
| <b>Normalize Colors</b>  |                                |   |
| <i>Sub Menu</i>  | <i>Options</i>                 | <i>Comments</i>   |
| Normalize Colors   | Adjustment of RGBW Intensities | Allows for fine adjustments to color intensities for near perfect color matching.   |

## 4. Security

Unwanted changes to the Fixture's Configuration or Setting can be controlled by locking the fixture's menu.

PLFRESNEL1 MKII LED Luminaires are shipped with a default numeric PIN code of "0000" (four zeros). Users may set their own PIN code (four-digit number) via **Settings > General > Set PIN**. When setting a PIN code, write it down and keep it in a secure location. Note, Philips Selecon does not have records of PIN codes established by users or owners.

---

**Note:** Contact Philips Selecon technical support if a unit is locked and the PIN code is lost for instructions on how to reset luminaire.

---



---

**Note:** If the Fixture is locked when it is powered down the fixture will remain in the locked state when powered up.

---

### Locking Fixture

#### To lock the fixture:

- Step 1. At Main Menu, press [MENU] and scroll to **Lock Fixture**. Note, default PIN is "0000" (four zeros).
- Step 2. Press [OK].
- Step 3. Enter four-digit, user-selectable, PIN code.
- Step 4. Use [LEFT ARROW] or [RIGHT ARROW] keys to highlight "YES", press [OK] or [ESC] twice to cancel action.
- Step 5. Fixture is now locked if locking process was not canceled as described in previous step.

---

**Note:** When the Fixture is Locked only the [ESC]/[MENU] key is functional. Pressing this key will display a request for a password. When a valid PIN code is entered the fixture is unlocked.

---

## 5. Presets

Presets are Color Mixes that are stored in the Fixture, they can be recalled to reproduce a specific output from the fixture. Presets are made up of a Color Mix; Red, Green, Blue, and White. They also have Intensity associated with them.

Presets can be recalled via the User interface or by a DMX channel, when under DMX control. The Preset's Intensity is applied if the User Interface is used; if DMX, the DMX Intensity channel is used for Intensity.

If the fixture is locked, Presets cannot be changed at the menu.

- Locked Presets are factory Calibrated, and their Color Mix cannot be changed by the user. Their Intensity can be changed. Three Presets 5 through 25 are Locked.
- Preset 0, the "off" preset is also Locked to the OFF value.
- If the fixture is unlocked, User Presets can have their Color Mix and Intensity changed without restriction.

---

**Note:** If the Color Mix of a Factory Calibrated Preset is changed, by turning protection Off, an '\*' is appended to the end of the Preset's Name to indicate that the Calibrated values have been changed.

---

---

**Note:** DMX will take priority over any menu selected preset.

---

## Editing Preset Names

On the Edit Preset screen, the option is available to edit the name of a preset, via Screen button. However, the names of Presets 0, 2, 3, and 4 cannot be edited. Scratch Pad, preset 1, can be changed but retains its original functionality.

Use the [LEFT ARROW] and [RIGHT ARROW] keys to select the character to be changed and use the [UP ARROW] and [DOWN ARROW] keys to change that character. The Character Scroll order is A-Z, space, 0-9. If you are scrolling up the Alpha character displays as Upper Case; if you are scrolling down the Alpha character displays as Lower Case. Stop on the character you want, ignoring case, then press the opposite [UP ARROW] or [DOWN ARROW] key if you want to change the case. [OK] to save changes, [ESC] to cancel changes.

## 6. Settings

Table 2, "Settings Menu User-Settable Parameters," on page 18 shows the user-settable parameters available in the Settings menu section.

To edit a value on the Setting Screen, use the [UP ARROW] or [DOWN ARROW] keys to move the highlight to the settings value you wish to change. Press [OK] to begin editing that value. Use the [UP ARROW], [DOWN ARROW], [LEFT ARROW] or [RIGHT ARROW] keys to make changes to the value. Press [OK] when complete to save changes, or [ESC] to cancel changes to that value.

When done making changes on the Settings Screen press [ESC] to re-boot fixture and implement changes. Fixture will not re-boot if nothing was changed.

Table 2: Settings Menu User-Settable Parameters

| Parameter      | Values   | Default              | Description  |
|----------------|--|----------------------|--|
| <b>General</b> |  |                      |  |
| Power, Fan     | Normal Mode (120W), Studio Mode (80W), or Quiet Mode (60W) | Normal Mode          | Sets the luminaire's output mode - Normal Mode (120W), Studio Mode (80W) or Quiet Mode (60W).  |
| Power-Up       | All presets  | Cool White           | Users can set what the default preset is when the unit is powered up. Factory default is Cool White.   |
| Red Correct    | No / Yes   | No                   | Turns on or off red correction.  |
| Reset Hours    | No, Yes  | No                   | Resets luminaire's operational hours.  |
| Set PIN        | ####   | 0 0 0 0 (four zeros) | A four-digit user-settable PIN code to lock the fixture.   |
| <b>Presets</b> |  |                      |  |
| Protected      | No, 5 - 25   | 5 - 25               | Determines if the factory Presets' Color Mix is protected from changes.  |
| Load Factory   | No, Yes  | No                   | Reload Factory Presets, Intensity changes will also be reloaded.   |
| <b>DMX</b>     |  |                      |  |
| Address        | 001 to 512   | 001                  | DMX512 address. Note, it can be set if displayed.  |
| Map            | 8-bit, 16-bit, or 5-Chan                                   | 16-bit               | Defines size/precision of DMX map. Color Mixing/Intensity in 16-bit provides higher resolution for precision control. 5-Chan provides minimal channel usage. |
| When no DMX    | Off, Hold, Hold 8Hr (8 hours), or No Output                | Hold                 | If DMX is detected and then goes away, this defines what will happen to the output. At end of 8Hr hold Fixture goes to No Output setting.                    |
| <b>Display</b> |  |                      |  |
| Flip Display   | No, Yes  | No                   | Flips (inverts) Display and Keypad Arrows.   |
| Adj Contrast   | 0 - 100%   | 50%                  | Use left or right arrow keys to adjust display contrast as desired.  |
| <b>Fixture</b> |  |                      |  |
| Fixture ID     | Shows Fixture Type - Profile, Cyc, or Fresnel              |                      | Shows luminaire type.  |

**Note:** To Exit the Settings screen, use the [ESC] key. [ESC] and [OK] can be used to cancel or save changes to an individual parameter. However, once a parameter has been accepted, by pressing [OK] that change cannot be undone/ canceled by pressing the [ESC] key.

# DMX CONTROL

This section contains information for operating the luminaire using DMX control in 16-Bit, 8-Bit, or 3-Channel (3-Chan) modes. For Menu options and detailed information, see "Settings" on page 17.

**Note:** These tables assume a DMX start address of 1. When a different starting address is used, this address becomes channel 1 function and other functions follow in sequence.

## 1. 16-Bit Mode

Table 3 provides DMX channel mapping of all DMX512 control values when the PLFRESNEL1 MKII LED Luminaire is in 16-bit DMX512 mode (as set by the luminaire's menu system).

**Table 3: PLFRESNEL1 MKII LED Luminaire DMX Channel Mapping (16-Bit Mode)**

| DMX Channel | Parameter              | Range DMX | Range%   | Default - recommended console default values | Description  |
|-------------|------------------------|-----------|----------|--|--|
| 1           | Intensity - High       | 0 - 65535 | 0 - 100% | 0  | 16-bit control for Intensity of LED settings.  |
| 2           | Intensity - Low        |           |          |  |  |
| 3           | Red - High Byte        | 0 - 65535 | 0 - 100% | 0  | 16-bit control of Red LEDs from 0 to full.   |
| 4           | Red - Low Byte         |           |          |  |  |
| 5           | Green - High Byte      | 0 - 65535 | 0 - 100% | 0  | 16-bit control of Green LEDs from 0 to full.   |
| 6           | Green - Low Byte       |           |          |  |  |
| 7           | Blue - High Byte       | 0 - 65535 | 0 - 100% | 0  | 16-bit control of Blue LEDs from 0 to full.  |
| 8           | Blue - Low Byte        |           |          |  |  |
| 9           | White - High Byte      | 0 - 65535 | 0 - 100% | 0  | 16-bit control of White LEDs from 0 to full.   |
| 10          | White - Low Byte       |           |          |  |  |
| 11          | Preset Color Selection | 0 - 255   | 0 - 100% | 0  | Used to access presets stored in fixture firmware, such as CCT presets, defined gel presets, etc.<br><br>No Preset Activated = DMX 0-3 ( <i>default</i> )<br>Color Preset 0 (Off) = DMX 4 - 7<br>Color Preset 1 (Scratch Pad) = DMX 8 - 11<br>Color Preset 2 (Warm White) = DMX 12 - 15<br>Color Preset 3 (Cool White) = DMX 16 - 19<br>Color Preset 4 (Daylight) = DMX 20 - 23<br>Color Preset 5 (Arc White) = DMX 24 - 27<br>Color Preset 6 (Red) = DMX 28 - 31<br>Color Preset 7 (Yellow) = DMX 32 - 35<br>Color Preset 8 (Daylight Blue) = DMX 36 - 39<br>Color Preset 9 (Magenta) = DMX 40 - 43<br>Color Preset 10 (Aqua) = DMX 44 - 47<br>Color Preset 11 (Medium Amber) = DMX 48 - 51<br>Color Preset 12 (Lavender) = DMX 52 - 55<br>Color Preset 13 (Blue) = DMX 56 - 59<br>Color Preset 14 (Light Pink) = DMX 60 - 63<br>Color Preset 15 (Green) = DMX 64 - 67<br>Color Preset 16 (Pink) = DMX 68 - 71<br>Color Preset 17 (Amber White) = DMX 72 - 75<br>Color Preset 18 (Dark Fuchsia) = DMX 76 - 79<br>Color Preset 19 (Light Amber) = DMX 80 - 83<br>Color Preset 20 (Steel Blue) = DMX 84 - 87<br>Color Preset 21 (Lt Green/Blue) = DMX 88 - 91<br>Color Preset 22 (Orange) = DMX 92 - 95<br>Color Preset 23 (Medium Pink) = DMX 96 - 99<br>Color Preset 24 (Cyan) = DMX 100 - 103<br>Color Preset 25 (Purple) = DMX 104 - 107<br>Color Preset 26 (Custom) = DMX 108 - 111<br>Color Preset 27 (Custom) = DMX 112 - 115<br>Color Preset 28 (Custom) = DMX 116 - 119<br>Color Preset 29 (Custom) = DMX 120 - 123<br>Color Preset 30 (Custom) = DMX 124 - 127<br>Color Preset 31 (Custom) = DMX 128 - 131<br>No Preset Activated = DMX 253 - 255 |

**Table 3: PLFRESNEL1 MKII LED Luminaire DMX Channel Mapping (16-Bit Mode)**

|    |                                  |         |          |     |   |
|----|----------------------------------|---------|----------|-----|---|
| 12 | <i>Not used (for future use)</i> |         |          |     |   |
| 13 | Intensity Time                   | 0 - 255 | 0 - 100% | 255 | Allows for luminaire timing of intensity. Profile should default to DMX 255 for smoothest console fade times. Refer to " <a href="#">PLFRESNEL1 MKII LED Luminaire DMX Timing Channel Detail</a> " on page 23 for more information on timing values.  |
| 14 | Color Time                       | 0 - 255 | 0 - 100% | 255 | Allows for luminaire timing of LEDs. Profile should default to DMX 255 for smoothest console fade times. Refer to " <a href="#">PLFRESNEL1 MKII LED Luminaire DMX Timing Channel Detail</a> " on page 23 for more information on timing values.   |
| 15 | Control                          | 0 - 255 | 0 - 100% | 0   | <p>Used to set different modes, parameters, and functions of the luminaire. Set control channel value for desired action. Hold value for at least 3 seconds. Set control channel value to 0 without any scaling.</p> <p>Default Setting on Console = DMX 0<br/>                     Display On/Off = DMX 3 - 4<br/>                     Reset All Settings to Defaults* = DMX 5 - 7<br/>                     Quiet Mode = DMX 8 - 10<br/>                     Studio Mode = DMX 11 - 13<br/>                     Normal Mode* = DMX 14 - 15<br/>                     Preset 1 Store = DMX 20 - 21<br/>                     Preset 2 Store (Intensity Only) = DMX 22 - 23<br/>                     Preset 3 Store (Intensity Only) = DMX 24 - 25<br/>                     Preset 4 Store (Intensity Only) = DMX 26 - 27<br/>                     Preset 5 Store = DMX 28 - 29<br/>                     Preset 6 Store = DMX 30 - 31<br/>                     Preset 7 Store = DMX 32 - 33<br/>                     Preset 8 Store = DMX 34 - 35<br/>                     Preset 9 Store = DMX 36 - 37<br/>                     Preset 10 Store = DMX 38 - 39<br/>                     Preset 11 Store = DMX 40 - 41<br/>                     Preset 12 Store = DMX 42 - 43<br/>                     Preset 13 Store = DMX 44 - 45<br/>                     Preset 14 Store = DMX 46 - 47<br/>                     Preset 15 Store = DMX 48 - 49<br/>                     Preset 16 Store = DMX 50 - 51<br/>                     Preset 17 Store = DMX 52 - 53<br/>                     Preset 18 Store = DMX 54 - 55<br/>                     Preset 19 Store = DMX 56 - 57<br/>                     Preset 20 Store = DMX 58 - 59<br/>                     Preset 21 Store = DMX 60 - 61<br/>                     Preset 22 Store = DMX 62 - 63<br/>                     Preset 23 Store = DMX 64 - 65<br/>                     Preset 24 Store = DMX 66 - 67<br/>                     Preset 25 Store = DMX 68 - 69<br/>                     Preset 26 Store = DMX 70 - 71<br/>                     Preset 27 Store = DMX 72 - 73<br/>                     Preset 28 Store = DMX 74 - 75<br/>                     Preset 29 Store = DMX 76 - 77<br/>                     Preset 30 Store = DMX 78 - 79<br/>                     Preset 31 Store = DMX 80 - 81<br/>                     Preset 32 Store = DMX 82 - 83</p> <p>Color Normalization ON* = DMX 100 - 103<br/>                     Color Normalization OFF = DMX 104 - 107<br/>                     Fixture Reset = DMX 108 - 112<br/>                     Red Correction ON* = DMX 113 - 115<br/>                     Red Correction OFF = DMX 116 - 118</p> <p><b>NOTE: * - Denotes default settings and return to default when performing control channel values 5 - 7.</b></p> |

## 2. 8-Bit Mode

Table 2-1 provides DMX channel mapping of all DMX512 control values when the PLFRESNEL1 MKII LED Luminaire is in 8-bit DMX512 mode (as set by the luminaire's menu system).

**Table 2-1: PLFRESNEL1 MKII LED Luminaire DMX Channel Mapping (8-Bit Mode)**

| DMX Channel | Parameter                        | Range DMX | Range%   | Default - recommended console default values | Description  |
|-------------|----------------------------------|-----------|----------|--|--|
| 1           | Intensity                        | 0 - 255   | 0 - 100% | 0  | 8-bit control for Intensity of LED settings.   |
| 2           | Red                              | 0 - 255   | 0 - 100% | 0  | 8-bit control of Red LEDs from 0 to full.  |
| 3           | Green                            | 0 - 255   | 0 - 100% | 0  | 8-bit control of Green LEDs from 0 to full.  |
| 4           | Blue                             | 0 - 255   | 0 - 100% | 0  | 8-bit control of Blue LEDs from 0 to full.   |
| 5           | White                            | 0 - 255   | 0 - 100% | 0  | 8-bit control of White LEDs from 0 to full.  |
| 6           | Preset Color Selection           | 0 - 255   | 0 - 100% | 0  | Used to access presets stored in fixture firmware, such as CCT presets, defined gel presets, etc.<br><br>No Preset Activated = DMX 0-3 ( <i>default</i> )<br>Color Preset 0 (Off) = DMX 4 - 7<br>Color Preset 1 (Scratch Pad) = DMX 8 - 11<br>Color Preset 2 (Warm White) = DMX 12 - 15<br>Color Preset 3 (Cool White) = DMX 16 - 19<br>Color Preset 4 (Daylight) = DMX 20 - 23<br>Color Preset 5 (Arc White) = DMX 24 - 27<br>Color Preset 6 (Red) = DMX 28 - 31<br>Color Preset 7 (Yellow) = DMX 32 - 35<br>Color Preset 8 (Daylight Blue) = DMX 36 - 39<br>Color Preset 9 (Magenta) = DMX 40 - 43<br>Color Preset 10 (Aqua) = DMX 44 - 47<br>Color Preset 11 (Medium Amber) = DMX 48 - 51<br>Color Preset 12 (Lavender) = DMX 52 - 55<br>Color Preset 13 (Blue) = DMX 56 - 59<br>Color Preset 14 (Light Pink) = DMX 60 - 63<br>Color Preset 15 (Green) = DMX 64 - 67<br>Color Preset 16 (Pink) = DMX 68 - 71<br>Color Preset 17 (Amber White) = DMX 72 - 75<br>Color Preset 18 (Dark Fuchsia) = DMX 76 - 79<br>Color Preset 19 (Light Amber) = DMX 80 - 83<br>Color Preset 20 (Steel Blue) = DMX 84 - 87<br>Color Preset 21 (Lt Green/Blue) = DMX 88 - 91<br>Color Preset 22 (Orange) = DMX 92 - 95<br>Color Preset 23 (Medium Pink) = DMX 96 - 99<br>Color Preset 24 (Cyan) = DMX 100 - 103<br>Color Preset 25 (Purple) = DMX 104 - 107<br>Color Preset 26 (Custom) = DMX 108 - 111<br>Color Preset 27 (Custom) = DMX 112 - 115<br>Color Preset 28 (Custom) = DMX 116 - 119<br>Color Preset 29 (Custom) = DMX 120 - 123<br>Color Preset 30 (Custom) = DMX 124 - 127<br>Color Preset 31 (Custom) = DMX 128 - 131<br>No Preset Activated = DMX 253 - 255 |
| 7           | <i>Not used (for future use)</i> |           |          |  |  |
| 8           | Timing                           | 0 - 255   | 0 - 100% | 255  | Allows for timing control of both the intensity and color parameters. Channel should default to 255 for smoothest actions using console and/or manual fades. Refer to " <a href="#">PLFRESNEL1 MKII LED Luminaire DMX Timing Channel Detail</a> " on <a href="#">page 23</a> for more information.   |

**Table 2-1: PLFRESNEL1 MKII LED Luminaire DMX Channel Mapping (8-Bit Mode)**

|   |         |         |          |   |   |
|---|---------|---------|----------|---|---|
| 9 | Control | 0 - 255 | 0 - 100% | 0 | <p>Used to set different modes, parameters, and functions of the luminaire. Set control channel value for desired action. Hold value for at least 3 seconds. Set control channel value to 0 without any scaling.</p> <p>Default Setting on Console = DMX 0<br/>                 Display On/Off = DMX 3 - 4<br/>                 Reset All Settings to Defaults* = DMX 5 - 7<br/>                 Quiet Mode = DMX 8 - 10<br/>                 Studio Mode = DMX 11 - 13<br/>                 Normal Mode* = DMX 14 - 15<br/>                 Preset 1 Store = DMX 20 - 21<br/>                 Preset 2 Store (Intensity Only) = DMX 22 - 23<br/>                 Preset 3 Store (Intensity Only) = DMX 24 - 25<br/>                 Preset 4 Store (Intensity Only) = DMX 26 - 27<br/>                 Preset 5 Store = DMX 28 - 29<br/>                 Preset 6 Store = DMX 30 - 31<br/>                 Preset 7 Store = DMX 32 - 33<br/>                 Preset 8 Store = DMX 34 - 35<br/>                 Preset 9 Store = DMX 36 - 37<br/>                 Preset 10 Store = DMX 38 - 39<br/>                 Preset 11 Store = DMX 40 - 41<br/>                 Preset 12 Store = DMX 42 - 43<br/>                 Preset 13 Store = DMX 44 - 45<br/>                 Preset 14 Store = DMX 46 - 47<br/>                 Preset 15 Store = DMX 48 - 49<br/>                 Preset 16 Store = DMX 50 - 51<br/>                 Preset 17 Store = DMX 52 - 53<br/>                 Preset 18 Store = DMX 54 - 55<br/>                 Preset 19 Store = DMX 56 - 57<br/>                 Preset 20 Store = DMX 58 - 59<br/>                 Preset 21 Store = DMX 60 - 61<br/>                 Preset 22 Store = DMX 62 - 63<br/>                 Preset 23 Store = DMX 64 - 65<br/>                 Preset 24 Store = DMX 66 - 67<br/>                 Preset 25 Store = DMX 68 - 69<br/>                 Preset 26 Store = DMX 70 - 71<br/>                 Preset 27 Store = DMX 72 - 73<br/>                 Preset 28 Store = DMX 74 - 75<br/>                 Preset 29 Store = DMX 76 - 77<br/>                 Preset 30 Store = DMX 78 - 79<br/>                 Preset 31 Store = DMX 80 - 81<br/>                 Preset 32 Store = DMX 82 - 83</p> <p>Color Normalization ON* = DMX 100 - 103<br/>                 Color Normalization OFF = DMX 104 - 107<br/>                 Fixture Reset = DMX 108 - 112<br/>                 Red Correction ON* = DMX 113 - 115<br/>                 Red Correction OFF = DMX 116 - 118</p> <p><b>NOTE: * - Denotes default settings and return to default when performing control channel values 5 - 7.</b></p> |
|---|---------|---------|----------|---|---|



### 3. DMX 5-Channel (5-Chan) Mode

Table 2-2 provides DMX channel mapping of all DMX512 control values when the PLFRESNEL1 MKII LED Luminaire is in 5-Channel (5-Chan) DMX512 mode (as set by the luminaire's menu system).

**Note:** This mode is for the simplest control of the luminaire's LEDs and intensity for limited control consoles and controllers.

**Table 2-2: PLFRESNEL1 MKII LED Luminaire DMX Channel Mapping (5-Chan Mode)**

| DMX Channel | Parameter | Range DMX | Range%   | Default - recommended console default values | Description                                  |
|-------------|-----------|-----------|----------|--|--|
| 1           | Intensity | 0 - 255   | 0 - 100% | 0  | 8-bit control for Intensity of LED settings. |
| 2           | Red       | 0 - 255   | 0 - 100% | 0  | 8-bit control Red LEDs.                      |
| 3           | Green     | 0 - 255   | 0 - 100% | 0  | 8-bit control Green LEDs.                    |
| 4           | Blue      | 0 - 255   | 0 - 100% | 0  | 8-bit control Blue LEDs.                     |
| 5           | White     | 0 - 255   | 0 - 100% | 0  | 8-bit control White LEDs.                    |

### 4. PLFRESNEL1 MKII LED Luminaire DMX Timing Channel Detail

Timing channel control improves the timed moves of certain groups of parameters. The PLFRESNEL1 MKII LED Luminaire provides two timing channels in 16-bit mode (one for intensity time and one for color time) and one timing channel in 8-bit (color and intensity timing combined). The luminaire uses its timing channel value to calculate a smooth continuous operation for a given time and transition.

#### Guidelines:

- Timing channels support time values from zero to 169 seconds.
- To use a timing channel instead of console timing, it is recommended to set the timing channel to the desired value and set cue and/or console cue fade time to zero. A combination of time controls can produce unexpected results.
- The default value setting in the profile should be 255 (proportional control) to allow smooth operation when using console timing.
- The timing channel data should change as a snap. A zero value will give the fastest operation, however, without any smoothing this can appear "steppy" in console timed moves.

Refer to "[PLFRESNEL1 MKII LED Luminaire DMX Timing Channel Detail](#)" on page 23 for more information.

Table 3: PLFRESNEL1 MKII LED Luminaire Timing Channel Detail

| % Value | DMX | = Seconds      |
|---------|-----|----------------|
|         | 0   | 0 (Full Speed) |
|         | 1   | 0.2            |
|         | 2   | 0.4            |
| 1       | 3   | 0.6            |
|         | 4   | 0.8            |
| 2       | 5   | 1              |
|         | 6   | 1.2            |
|         | 7   | 1.4            |
| 3       | 8   | 1.6            |
|         | 9   | 1.8            |
| 4       | 10  | 2              |
|         | 11  | 2.2            |
|         | 12  | 2.4            |
| 5       | 13  | 2.6            |
|         | 14  | 2.8            |
| 6       | 15  | 3              |
|         | 16  | 3.2            |
|         | 17  | 3.4            |
| 7       | 18  | 3.6            |
|         | 19  | 3.8            |
| 8       | 20  | 4              |
|         | 21  | 4.2            |
|         | 22  | 4.4            |
| 9       | 23  | 4.6            |
|         | 24  | 4.8            |
| 10      | 25  | 5              |
|         | 26  | 5.2            |
|         | 27  | 5.4            |
| 11      | 28  | 5.6            |
|         | 29  | 5.8            |
|         | 30  | 6              |
| 12      | 31  | 6.2            |
|         | 32  | 6.4            |
| 13      | 33  | 6.6            |
|         | 34  | 6.8            |
|         | 35  | 7.0            |
| 14      | 36  | 7.2            |
|         | 37  | 7.4            |
| 15      | 38  | 7.6            |
|         | 39  | 7.8            |
|         | 40  | 8              |
| 16      | 41  | 8.2            |
|         | 42  | 8.4            |
| 17      | 43  | 8.6            |
|         | 44  | 8.8            |
|         | 45  | 9              |
| 18      | 46  | 9.2            |
|         | 47  | 9.4            |
| 19      | 48  | 9.6            |
|         | 49  | 9.8            |
|         | 50  | 10             |
| 20      | 51  | 10.2           |

| % Value | DMX | = Seconds |
|---------|-----|-----------|
|         | 52  | 10.4      |
|         | 53  | 10.6      |
| 21      | 54  | 10.8      |
|         | 55  | 11        |
| 22      | 56  | 11.2      |
|         | 57  | 11.4      |
|         | 58  | 11.6      |
| 23      | 59  | 11.8      |
|         | 60  | 12        |
| 24      | 61  | 12.2      |
|         | 62  | 12.4      |
|         | 63  | 12.6      |
| 25      | 64  | 12.8      |
|         | 65  | 13        |
| 26      | 66  | 13.2      |
|         | 67  | 13.4      |
|         | 68  | 13.6      |
| 27      | 69  | 13.8      |
|         | 70  | 14        |
| 28      | 71  | 14.2      |
|         | 72  | 14.4      |
|         | 73  | 14.6      |
| 29      | 74  | 14.8      |
|         | 75  | 15        |
| 30      | 76  | 15.2      |
|         | 77  | 15.4      |
|         | 78  | 15.6      |
| 31      | 79  | 15.8      |
|         | 80  | 16        |
|         | 81  | 16.2      |
| 32      | 82  | 16.4      |
|         | 83  | 16.6      |
| 33      | 84  | 16.8      |
|         | 85  | 17        |
|         | 86  | 17.2      |
| 34      | 87  | 17.4      |
|         | 88  | 17.6      |
| 35      | 89  | 17.8      |
|         | 90  | 18        |
|         | 91  | 18.2      |
| 36      | 92  | 18.4      |
|         | 93  | 18.6      |
| 37      | 94  | 18.8      |
|         | 95  | 19        |
|         | 96  | 19.2      |
| 38      | 97  | 19.4      |
|         | 98  | 19.6      |
| 39      | 99  | 19.8      |
|         | 100 | 20        |
|         | 101 | 21        |
| 40      | 102 | 22        |
|         | 103 | 23        |
|         | 104 | 24        |
| 41      | 105 | 25        |

| <b>% Value</b> | <b>DMX</b> | <b>= Seconds</b> |
|----------------|------------|------------------|
|                | 106        | 26               |
| 42             | 107        | 27               |
|                | 108        | 28               |
|                | 109        | 29               |
| 43             | 110        | 30               |
|                | 111        | 31               |
| 44             | 112        | 32               |
|                | 113        | 33               |
|                | 114        | 34               |
| 45             | 115        | 35               |
|                | 116        | 36               |
| 46             | 117        | 37               |
|                | 118        | 38               |
|                | 119        | 39               |
| 47             | 120        | 40               |
|                | 121        | 41               |
| 48             | 122        | 42               |
|                | 123        | 43               |
|                | 124        | 44               |
| 49             | 125        | 45               |
|                | 126        | 46               |
|                | 127        | 47               |
| 50             | 128        | 48               |
|                | 129        | 49               |
| 51             | 130        | 50               |
|                | 131        | 51               |
|                | 132        | 52               |
| 52             | 133        | 53               |
|                | 134        | 54               |
| 53             | 135        | 55               |
|                | 136        | 56               |
|                | 137        | 57               |
| 54             | 138        | 58               |
|                | 139        | 59               |
| 55             | 140        | 60               |
|                | 141        | 61               |
|                | 142        | 62               |
| 56             | 143        | 63               |
|                | 144        | 64               |
| 57             | 145        | 65               |
|                | 146        | 66               |
|                | 147        | 67               |
| 58             | 148        | 68               |
|                | 149        | 69               |
| 59             | 150        | 70               |
|                | 151        | 71               |
|                | 152        | 72               |
| 60             | 153        | 73               |
|                | 154        | 74               |
|                | 155        | 75               |
| 61             | 156        | 76               |
|                | 157        | 77               |
| 62             | 158        | 78               |
|                | 159        | 79               |

| % Value | DMX | = Seconds |
|---------|-----|-----------|
|         | 160 | 80        |
| 63      | 161 | 81        |
|         | 162 | 82        |
| 64      | 163 | 83        |
|         | 164 | 84        |
|         | 165 | 85        |
| 65      | 166 | 86        |
|         | 167 | 87        |
| 66      | 168 | 88        |
|         | 169 | 89        |
|         | 170 | 90        |
| 67      | 171 | 91        |
|         | 172 | 92        |
| 68      | 173 | 93        |
|         | 174 | 94        |
|         | 175 | 95        |
| 69      | 176 | 96        |
|         | 177 | 97        |
|         | 178 | 98        |
| 70      | 179 | 99        |
|         | 180 | 100       |
| 71      | 181 | 101       |
|         | 182 | 102       |
|         | 183 | 103       |
| 72      | 184 | 104       |
|         | 185 | 105       |
| 73      | 186 | 106       |
|         | 187 | 107       |
|         | 188 | 108       |
| 74      | 189 | 109       |
|         | 190 | 110       |
| 75      | 191 | 111       |
|         | 192 | 112       |
|         | 193 | 113       |
| 76      | 194 | 114       |
|         | 195 | 115       |
| 77      | 196 | 116       |
|         | 197 | 117       |
|         | 198 | 118       |
| 78      | 199 | 119       |
|         | 200 | 120       |
| 79      | 201 | 121       |
|         | 202 | 122       |
|         | 203 | 123       |
| 80      | 204 | 124       |
|         | 205 | 125       |
| 81      | 206 | 126       |
|         | 207 | 127       |
|         | 208 | 128       |
| 82      | 209 | 129       |
|         | 210 | 130       |
|         | 211 | 131       |
| 83      | 212 | 132       |
|         | 213 | 133       |

| % Value | DMX               | = Seconds |
|---------|-------------------|-----------|
| 84      | 214               | 134       |
|         | 215               | 135       |
|         | 216               | 136       |
| 85      | 217               | 137       |
|         | 218               | 138       |
| 86      | 219               | 139       |
|         | 220               | 140       |
|         | 221               | 141       |
| 87      | 222               | 142       |
|         | 223               | 143       |
| 88      | 224               | 144       |
|         | 225               | 145       |
|         | 226               | 146       |
| 89      | 227               | 147       |
|         | 228               | 148       |
|         | 229               | 149       |
| 90      | 230               | 150       |
|         | 231               | 151       |
| 91      | 232               | 152       |
|         | 233               | 153       |
|         | 234               | 154       |
| 92      | 235               | 155       |
|         | 236               | 156       |
| 93      | 237               | 157       |
|         | 238               | 158       |
|         | 239               | 159       |
| 94      | 240               | 160       |
|         | 241               | 161       |
| 95      | 242               | 162       |
|         | 243               | 163       |
|         | 244               | 164       |
| 96      | 245               | 165       |
|         | 246               | 166       |
| 97      | 247               | 167       |
|         | 248               | 168       |
|         | 249               | 169       |
| 98      | 250*              | 60mS      |
|         | 251*              | 80mS      |
| 99      | 252*              | 100mS     |
|         | 253*              | 120mS     |
|         | 254*              | 140mS     |
| 100     | 255*<br>(default) | 160mS     |

**Note:** \* DMX values 250 to 255 provide smoothing when using console fade timing. DMX value 255 (recommended default) will provide the smoothest timing.

# CLEANING AND CARE

---



**WARNING!** All cleaning should be performed with power completely removed from the luminaire. Never remove protective covers when luminaire is powered. Wear appropriate protective eye wear and gloves when cleaning the fixture. All service and maintenance, other than described herein, should be performed by a qualified technician or Authorized Service Center.

---

## 1. Special Cleaning and Care Instructions

Being a solid-state fixture, and unlike most fixtures, the PLFRESNEL1 MKII LED Luminaire requires very little routine maintenance by the user. This section covers portions of the luminaire that can be removed for cleaning.

The PLFRESNEL1 MKII LED Luminaire special care when it comes to cleaning front lens assembly. Additional care needs to be taken with the plastic components because they are much easier to scratch or damage than glass.

The following is a list of cleaning materials required to care for your PLFRESNEL1 MKII LED Luminaire:

- Lint free lens tissue
- Lint or powder free gloves
- Reagent grade isopropyl alcohol\*
- A mild soap solution.

**Note:** \*Reagent grade isopropyl alcohol is good to use on the PLFRESNEL1 MKII LED Luminaire optics with anti-reflection coatings.

---

If the lens is still dirty after using isopropyl alcohol, for instance if fingerprints or oil is just redistributed and not cleaned off the optics, then a mild soap and water solution can be used to gently wash the lens. Repeat the cleaning with isopropyl alcohol to eliminate streaks and soap residue.

---



**WARNING!** Under no circumstances should ammonia-based cleaners, acetone, or other harsh solvents be used on or near the PLFRESNEL1 MKII LED Luminaire. These types of cleaners or solvents can permanently damage the optics or housings of the fixture.

---

If you have any questions regarding the use or care of your PLFRESNEL1 MKII LED Luminaire, please contact Philips Selecon technical support or your local Authorized Dealer.

## 2. Service and Maintenance

For all other service and maintenance issues, please contact your local Philips Selecon office or an Authorized Service Center.

---



**WARNING!** Disassembly (other than as described herein), alterations, unauthorized service, etc. will void the product warranty. Contact your local Philips Selecon office or an Authorized Service Center for technical support and service.

---

## 3. Accessories

Only Philips Selecon approved accessories should be used with your PLFRESNEL1 MKII LED Luminaire. For a list of available accessories from Philips Selecon, please see "[Accessories](#)" on [page 4](#). For questions regarding accessories, please contact your local Authorized Philips Selecon Dealer or Philips Selecon office.

# TROUBLESHOOTING

## 1. Troubleshooting Guide

The chart below provides possible causes and remedies for various error messages and/or symptoms.



**WARNING!** Any service and maintenance (including troubleshooting), other than described herein should be performed by an Authorized Philips Selecon Dealer or Service Center.

| Description                    | Symptom   | Possible Cause/Remedy  |
|--------------------------------|---|--|
| No light output.               | Fixture will not produce or output light                | Unit is set to Preset Off...<br>Make sure unit is set to proper Preset.<br>DMX command to 0 intensity...<br>Adjust intensity to higher level.  |
| No power at luminaire.         | Luminaire does not power up                             | Circuit not energized...<br>verify circuit breaker is turned on.<br>Not plugged in...<br>ensure A/C cable is connected to power source.<br>Power cable wired incorrectly...<br>verify power cable and connector are wired correctly.<br>See " <a href="#">Connecting Power</a> " on page 7 for more information.   |
| DMX Data Control.              | Fixture will not respond to DMX commands.               | Not detecting DMX data...<br>Disconnect and reconnect DMX input cable.<br>Unit is not set to be controlled by DMX - check menu settings.<br>Check all DMX connections (at control source and luminaire).<br>DMX data cable not wired correctly or has a broken conductor...<br>check DMX data cable for proper wiring.<br>See " <a href="#">Connecting to the DMX512 Network</a> " on page 8 for more information.                                       |
| LED (light) is getting dimmer. | Fixture appears not to be operating at full brightness. | Luminaire has detected an over temperature condition...<br>The luminaire will reduce power to its LED if it senses that the LED is operating over the specified temperature. LED temperature is read and recorded through a thermistor imbedded in the LED chip.<br>Fan is not operating. Listen for fan operation or adjust settings to increase fan speed. On luminaires with a display check system status menu for status of fans and LED operation. |
| Local programming.             | Unit will not allow local programming or changes.       | Password protection is on (locked)...<br>Input proper password to allow local programming and/or adjustments.<br>Unit is controlled by DMX...<br>Disconnect input cables to check issue.   |



## TECHNICAL SPECIFICATIONS

### 1. PLFRESNEL1 MKII LED Luminaire Operational Specifications

|                      |   |
|----------------------|---|
| Source:              | True RGBW 120 Watt LED chip   |
| Light Output:        | > 2,000 lumens  |
| Beam Angle:          | 15 to 54 Degrees (user adjustable)  |
| Power Consumption:   | 140 Watts (max., RGBW at 100%)  |
| Input Voltage:       | 100V to 240V (+/- 10%, auto-ranging)  |
| Current:             | 1.2 Amps (115V) / 0.6 Amps (230V)   |
| Frequency:           | 50/60Hz   |
| Ambient Temperature: | 0 to 40 degrees C (32 to 104 degrees F)   |
| Humidity:            | 5%-95% Non condensing   |
| Cooling:             | Forced-Air  |
| Weight:              | 11.4 lbs (5.2 kg) - Luminaire and topbox only (no mount, AC input cable or accessories) |
| Compliance:          | cETLus Listed, CE, and C-Tick Marked  |

**Note:** Common model specifications shown. For specific model specifications, features, and accessories, refer to the product specification sheet or visit the Philips Selecon web site at [www.seleconlight.com](http://www.seleconlight.com) for more details.

### 2. PLFRESNEL1 MKII LED Luminaire Dimensions

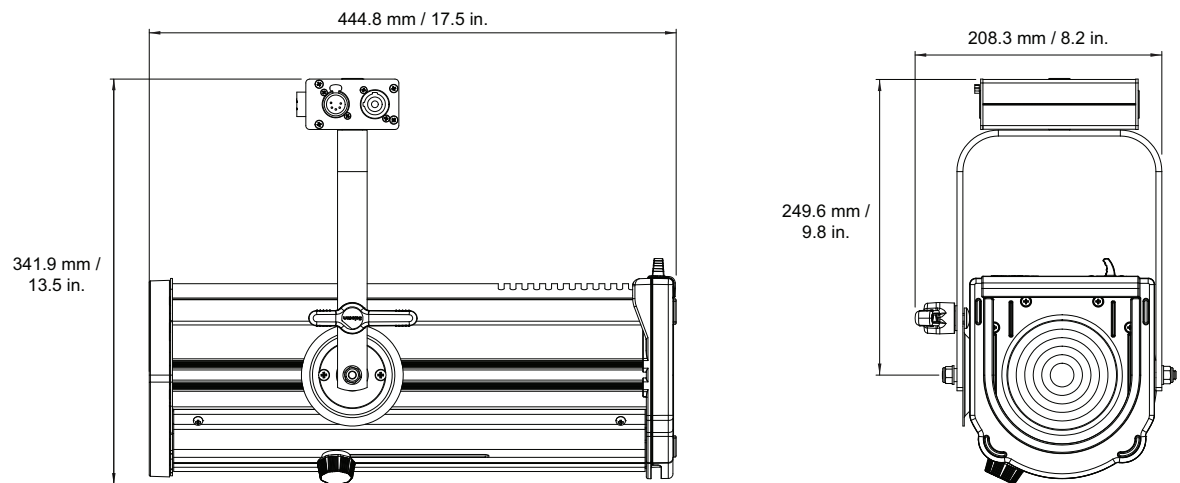

**PHILIPS**

**Selecon**

Philips Selecon  
Dallas  
10911 Petal Street  
Dallas, TX 75238  
Tel: +1 214-647-7880  
Fax: +1 214-647-8031

Philips Selecon  
Hong Kong  
Unit C, 14/F, Roxy Industrial Centre  
No. 41-49 Kwai Cheong Road  
Kwai Chung, N.T., Hong Kong  
Tel: +852 2796 9786  
Fax: +852 2798 6545

Philips Selecon  
Auckland  
19-21 Kawana Street  
Northcote, Auckland 0627  
New Zealand  
Tel: +64 9 481 0100  
Fax: +64 9 481 0101

Philips Selecon  
Europe  
Rondweg zuid 85  
Winterswijk 7102 JD  
The Netherlands  
Tel: +31(0) 543-542516

[www.seleconlight.com](http://www.seleconlight.com)